

GE Digital Energy
Power Quality

Zenith

ZTSCT/ZBTSCT Series

Closed Transition Transfer & Transfer Bypass-Isolation Switches
100-4000 Amps

Operation & Maintenance Manual

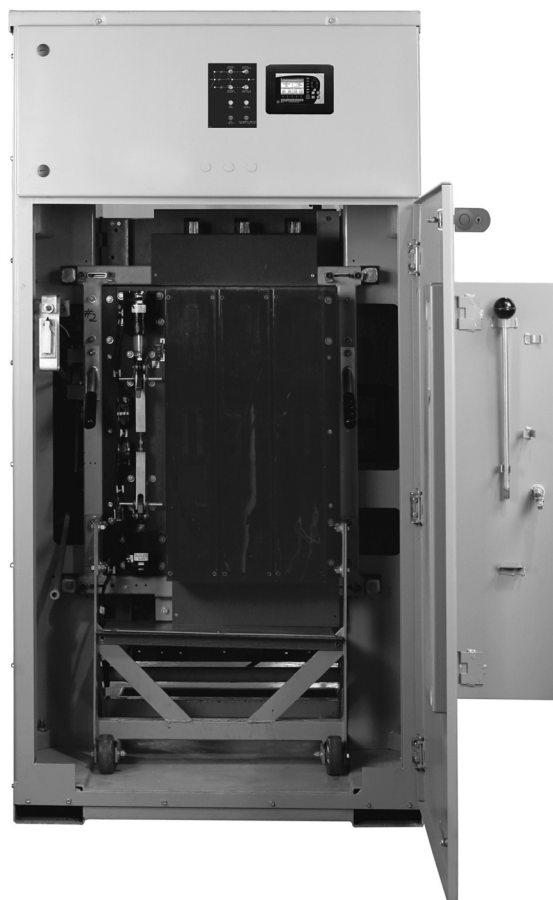

Authorized Service

For GE parts and service, call: 773 299-6600

Table of Contents

	Page		Page
Introduction	ii	Testing	19
Safety	1	Introduction	19
Equipment Inspection and Storage	1	Test Options	19
Final Equipment Inspection	1	ATS Testing	20
Mounting	1	Open Transition	20
Installation	2	Closed Transition	21
Power Connections	2	Emergency Service Procedure	
Engine Start Control Connections	2-3	for Extended Parallel Time	22
Initial Energization	3-4	Sequence of Operation	23
Control Connections	5	Open Transition	23
Entelli-Switch 250 Microprocessor Controller	6	Closed Transition	24
Overview	6	Bypass-Isolation Operation	25
LCD & Keypad	7	100-400 AMP	26
User Setting for Voltage & Frequency	8	600-1200 AMP	27
Accessory Group Packages	9	1600-4000 AMP	28
Accessory Definitions	10-13	1600-3000 AMP, Horizontal Bypass	29
How to Set the System Clock	13	Controls Power Supply (CPS)	30
CDT One Event Timer Exerciser	14	Schematics	31
CDP Clock Exerciser	15	Troubleshooting & Diagnostics	32
User Setup - CFG Menu	16	Maintenance and Testing	33
User Setup - SET Menu	17	Inspection and Cleaning	33
User Setup - System Info	18	Servicing	33
		Testing	33

Introduction

GE Zenith Transfer Switches are used to provide a continuous source of power for lighting and other critical loads by automatically transferring from Source 1 power to Source 2 power in the event that source 1 voltage falls below preset limits.

Voltage sensing and system control is performed via a state-of-the-art microcontroller located on the cabinet door. It is designed to give highly accurate control of the transfer switch system.

All GE Zenith transfer switches are designed for use on emergency or standby systems, and are rated for total system or motor loads. Transfer switches are UL Listed under Standard 1008 and CSA Certified under Standard C22.2 No. 178 and IEC Listed under Standard 947.

NOTES: A protective device such as a molded case circuit breaker or fused disconnect switch MUST be installed on both sources of incoming power for circuit protection and as a disconnection device.
All references made within this manual about the term "S1" or "Source 1" relate to a Normal Power Source. All references made about the term "S2" or "Source 2" relate to an Emergency or Alternative Power Source.

Safety

⚠ DANGER ⚠

HAZARDOUS VOLTAGE (Can Cause Severe Injury or Death)

Turn OFF all power before installation, adjustment, or removal of transfer switch or any of its components.

The safe operation of your switch is GE Zenith's focus. The proper storage, installation, operation and maintenance will help increase the life of the switch.

⚠ CAUTION ⚠

Due to hazardous voltage and current, GE Zenith recommends that a GE Zenith Certified technician or a qualified electrician must perform the installation and maintenance of the switch.

Equipment Inspection and Storage

Once you have received the transfer switch, inspect it for any damage. This includes damage to the enclosure, power panel, control panel and wiring harness. If any damage is found or suspected, file a claim as soon as possible with the carrier and notify the nearest GE Zenith representative.

Before installation, if it is necessary, store the transfer switch in a clean dry place, protected from dirt and water. Provide ample air circulation and heat, if necessary, to prevent condensation.

Storage Temperature	Operating Temperature (Ambient):	Humidity
-30°C to +75°C (-22°F to +167°F)	40-400 AMP (molded shell) 40-4000 AMP (all other frame and panel types) -20°C to +60°C (-4°F to +149°F)	5% to 95% (non-condensing)

Final Equipment Inspection

Prior to energizing the transfer switch:

1. Remove any debris incurred, with a vacuum, due to shipment or installation.
2. Verify that all cabled connections are correct and that phase rotation of both sources match.

⚠ WARNING ⚠

Do not use a blower since debris may become lodged in the electrical and mechanical components and cause damage.

3. Check engine start connections.
4. Verify the correct connection of all control wires.
5. Check settings of all timers and adjust as necessary.
6. Adjust any optional accessories as required.
7. Check the lug torque values of the power connections.

NOTE: Lug torque values are specified in table 2 on pg.2.

8. Make sure that all covers and barriers are installed and properly fastened.

NOTE: Power panels ship from GE Zenith in Source 1 Position.

Each GE Zenith transfer switch is factory wired and tested. A complete information package is furnished with each switch which includes:

- a. Sequence of operation.
- b. Description and operation of all accessories supplied.
- c. Power panel connection diagram and schematic.
- d. Description and identification of all customer field connections.

Installation of GE Zenith transfer switches includes:

- a. Mounting the transfer switch cabinet.
- b. Connection of Source 1, Source 2, and Load cables or bus bars.
- c. Connection of external control circuits as required.

Mounting

Adequate lifting means must be used to mount the transfer switch into place. The recommended method for moving the transfer switch using the lifting eyes, where supplied, and a spreader bar is illustrated in *Figure 1*. Enough room should be allowed to open the cabinet doors fully for inspection and servicing of the switch per NEC and local codes.

⚠ CAUTION ⚠

Before drilling conduit entry holes or any accessory mounting holes, cover and protect the switch and control panel to prevent dirt and metal fragments from entering the mechanical and electrical components.

Failure to do so may result in damage and malfunction of the switch.

Installation

⚠ DANGER ⚠

**HAZARDOUS VOLTAGE
(Can Cause Severe Injury or Death)**

Turn OFF all power before installation, adjustment, or removal of transfer switch or any of its components.

Power Connections

GE Zenith transfer switches are supplied with UL listed solderless screw type terminals as standard for the Source 1, Source 2 and Load power connections. *Table 1* lists the number and sizes of cable lugs supplied as standard for each switch amp rating.

Connect the Source 1, Source 2, and Load conductors to the clearly marked terminals on the transfer switch. Remove surface oxides from cables by cleaning with a wire brush. Verify that all connections are correct before tightening the lugs. All cable lug connections must be tightened to the proper torque values as shown in *Table 2*.

NOTE: Do not run cables or wiring behind front-connected transfer switches.

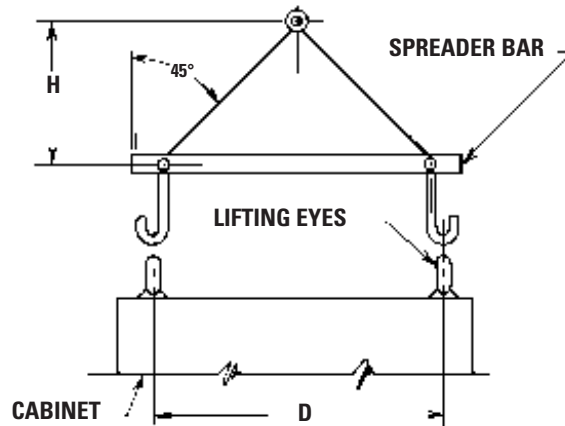

Figure 1

NOTE: When lifting the switch using a spreader bar, height H must be equal to half of distance D.

Power Connections: Screw Type Terminals for External Power Connections

Switch Size (Amps)	Source 1, Source 2 & Load Terminals		Neutral Bar (When Required)	
	Cable Per Pole	Range of Wire Sizes	No. of Cables	Range of Wire Sizes
40	1	#8 AWG to 1/0	3	#8 AWG to 1/0
80	1	#8 AWG to 1/0	3	#8 AWG to 1/0
100	1	#8 AWG to 1/0	3	#8 AWG to 1/0
150	1	#8 AWG to 3/0	3	#8 AWG to 300 MCM
200, 225, 2500	1	#6 AWG to 250 MCM	3	#6 AWG to 300 MCM
260, 300*, 400	1	#4 AWG to 600 MCM	3	#4 AWG to 300 MCM
600	2	#2 AWG to 600 MCM	8	#2 AWG to 600 MCM
800, 1000, 1200	4	#2 AWG to 600 MCM	12	#2 AWG to 600 MCM
1600, 2000 2600, 3000, 4000	Line, Load and Neutral terminals are located in the rear of switch and arranged for bus bar locations			

Table 1

Engine Start Control Connections

Engine-start control wires connect to control terminals beside the MX250. Engine start terminals are indicated by a schematic symbol (the symbol indicates the contact state for a de-energized normal source). *Figure 3* shows the engine-start contacts.

Make all other necessary control connections to the control panel terminal blocks per the schematics supplied with the ATS.

NOTE: All control wires (18-12 AWG) must be torqued to 19 in/lbs.

Tightening Torque for Lugs

Socket Size Across Flats	Torque	
	Lb. - In.	Lb. - Ft.
1/8	45	4
5/32	100	8
3/16	120	10
7/32	150	12
1/4	200	17
5/16	275	23
3/8	375	31
1/2	500	42
9/16	600	50

Table 2

⚠ DANGER ⚠

HAZARDOUS VOLTAGE (Can Cause Severe Injury or Death)

Turn OFF all power before installation, adjustment, or removal of transfer switch or any of its components.

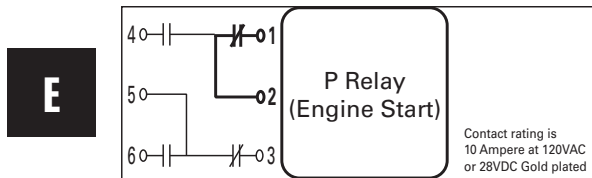

Figure 2

Engine Start Control Connections

The engine-start terminals are clearly identified by a label on the microcontroller backplate. In the case of manual transfer switches, or in other applications not requiring the microprocessor, clearly marked terminal blocks are provided in the upper left corner of the control panel for the engine start control wires.

Figure 3 shows location of engine start connections for Bypass Isolation Transfer Switch. Figure 6 (pg.5) shows location of engine start connections for Automatic Transfer Switch.

Terminals for field connections to the A3 Source 2 auxiliary contacts and the A4 Source 1 auxiliary contacts are also provided. These terminals are clearly marked and appear on the side of the power panel. On 400 amp metal frame units these terminals appear on the bracket above the operator handle.

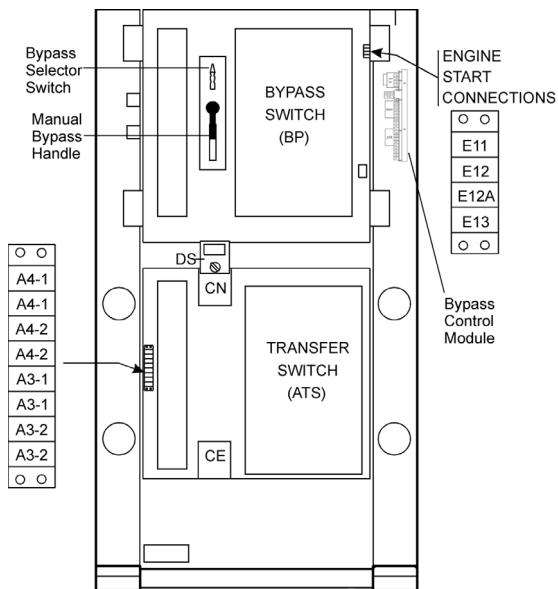

Figure 3 (Typical)

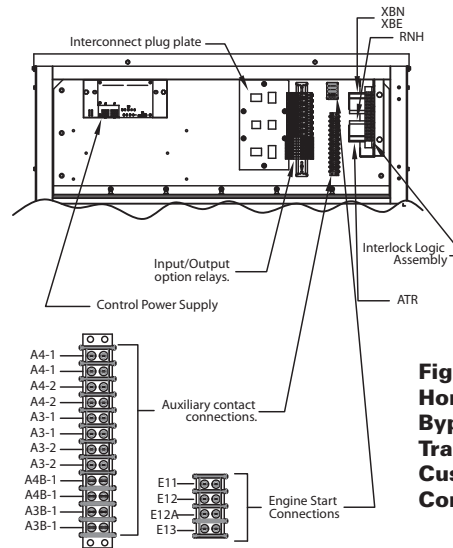

Figure 3A - Horizontal Bypass/Isolation Transfer Switch Customer Connections

Initial Energization

Before proceeding, refer to the information package supplied with the ATS and read and understand the information on all accessories provided.

1. Unlock the enclosure.
2. Open the enclosure.
3. Verify the correct system voltage.

NOTE: The equipment rating nameplate on the transfer switch lists the voltage. See Figure 4.

4. Close Source 1 circuit breaker.

NOTE: The controller will illuminate Source 1 Available LED if proper voltage is sensed.

5. Verify the phase to phase voltages at Source 1 line terminals.
6. Close Source 2 circuit breaker.
7. Start the generator's engine.

NOTE: The controller will illuminate Source 2 Available LED when preset voltage and frequency levels are reached.

8. Verify the phase to phase voltages at Source 1 line terminals.
9. Verify that the phase rotation of Source 1 is the same as the phase rotation of Source 2.
10. Shut down the generator's engine.
11. Place the starting control in the Automatic position.
12. Complete the visual inspection of the transfer switch.
13. Close the enclosure.
14. Lock the enclosure.



Installation *(cont'd)*

Initial Energization *(cont'd)*

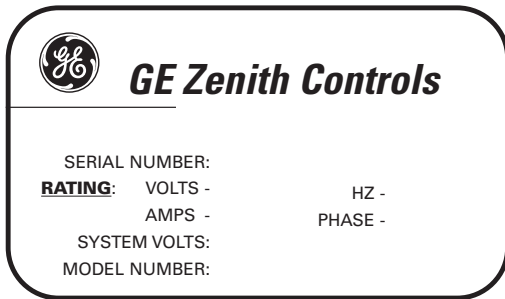

Figure 4

⚠ CAUTION ⚠

Certain accessories, per specific schematics, can inhibit automatic transfer. Engine Gen-Set could start when engine control wires are attached.

After all options and accessories are checked and verified, follow these steps to set up the ATS. Refer to Entelli-Switch 250 display *Figure 5*. The annunciation LEDs illuminate to indicate (1) source availability, (2) ATS position, and (3) Entelli-Switch 250 control function (timing).

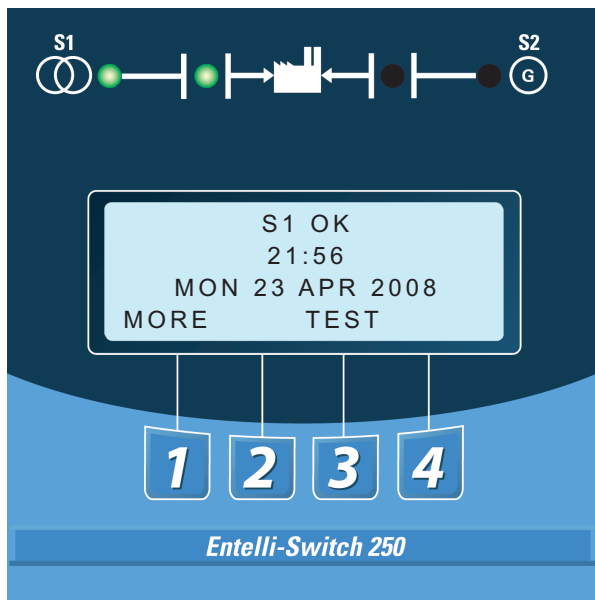

Figure 5 – LCD and keypad

1. Unlock the enclosure.
2. Open the enclosure.
3. Place the Disconnect Switch in the Inhibit.

NOTE: This step is only performed if the “DS” Option was purchased.

4. Close the external (up-stream) Source 1 circuit breaker.

NOTES: Source 1 Available and Source 1 Position LED’s will illuminate.

If Source 1 Available LED does not illuminate, verify that Source 1 Voltage is above the preset restore value.

The Gen-Set will start and run while Source 2 stop Delay Timer is timing.

5. Close the External (up-stream) Source 2 line circuit breaker.
6. Start the engine generator in MANUAL mode.

NOTE: When the voltage and frequency reach preset values, the Source 2 Available LED will illuminate.

7. Verify the phase to phase voltages at Source 2 line terminals.

8. Verify that the phase rotation of Source 2 is the same as the phase rotation of Source 1.



9. Shut down the generator’s engine. (Place in Automatic Mode.)

NOTE: Source 2 Available LED will turn off.

NOTE: The engine generator will continue to run for the duration of Source 2 Stop Delay Timer.

10. Place the disconnect switch to ENABLE.
11. Complete the visual inspection of the transfer switch.
12. Close the enclosure.
13. Lock the enclosure.

⚠ WARNING ⚠

When performing a hi-pot or dielectric test on the power section, **DISCONNECT** the control panel plugs from the microprocessor to avoid potential damage.

Installation *(cont'd)*

⚠ DANGER ⚠

**HAZARDOUS VOLTAGE
(Can Cause Severe Injury or Death)**

Turn OFF all power before installation, adjustment, or removal of transfer switch or any of its components.

Control Connections

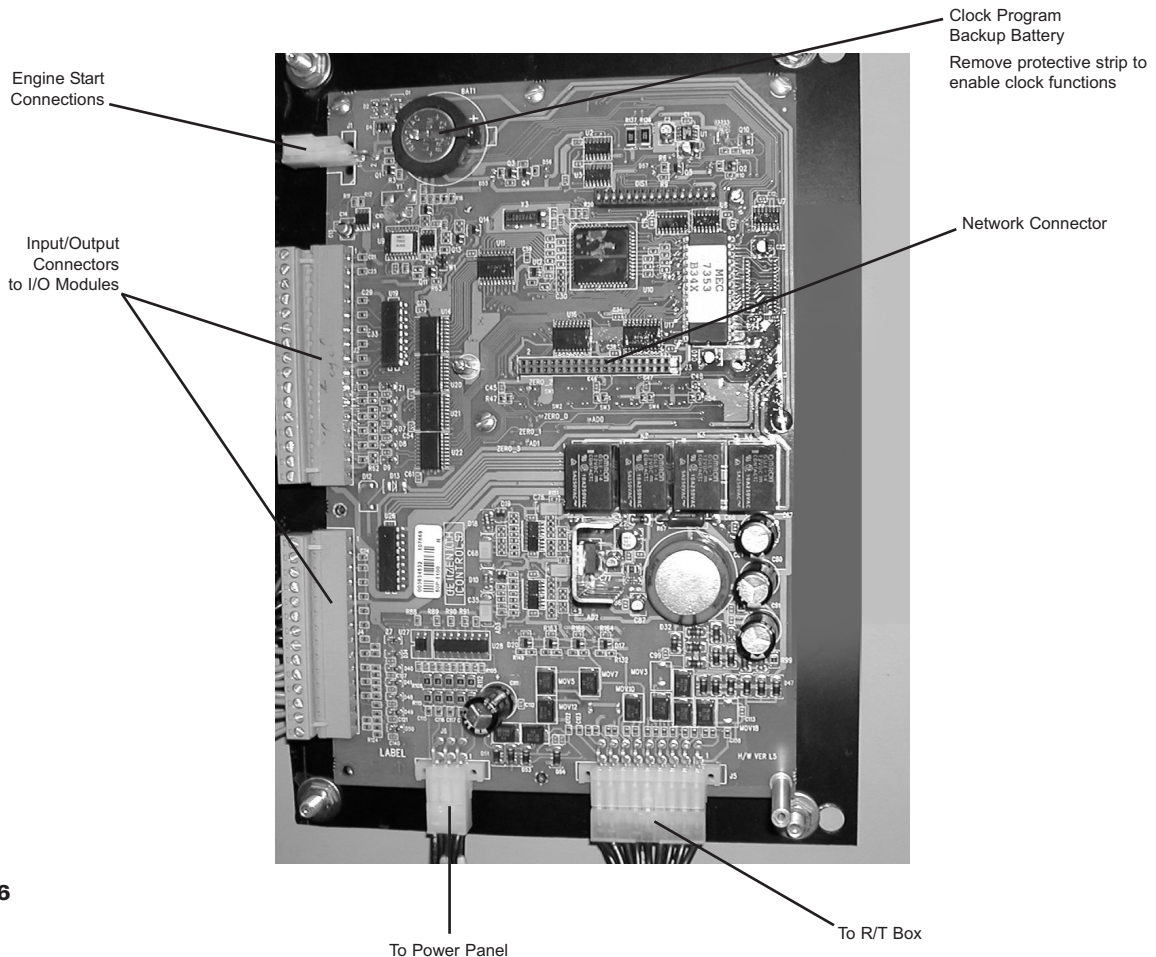

Figure 6

A complete information package is furnished with each transfer switch including a complete connection diagram and schematic which details all necessary control circuit field connections.

The engine start control wires connect to the engine start relay terminals located to the left of the microprocessor. Figure 6 shows the location of these terminals.

The terminals are clearly identified by a label on the microcontroller backplate. In the case of manual transfer switches, or in other applications not requiring the microprocessor, clearly marked terminal blocks are provided in the upper left corner of the control panel for the engine start control wires.

Entelli-Switch 250 Controller

Entelli-Switch 250 Controller

Consists of two major assemblies:

I. The **Microprocessor** contains the following:

- A. Entelli-Switch 250 Board - Customer Input and Output (I/O) for system interface. Located on the left hand side of the back of the unit (see figure 7)
 1. I/O accessories that can be found here are:
 - a. Engine start relay P output
 - b. Pre-Signal to transfer T3, W3 and UMD output (optional)
 - c. Transfer Inhibit Q3 and Q7 input (optional)
 - d. Remote test Q2 input (optional)
 - e. Network interface ZNET input/output (optional)
- B. LCD and Keypad located on the exterior of the door (see figure 8)
 1. User accessibility to the following:
 - a. LED indication of source availability
 - b. LED indication of transfer switch position
 - c. LCD screen indicates:
 - (1) timer count down (numeric)
 - (2) event reporting (text)
 - d. Keypad provides user interface to:
[in conjunction with LCD screen]
 - (1) Setting sensors and timers
 - (2) Configuring logic accessories

II. The **Controls Power Supply (CPS)**

Contains transformers which drop line voltage to control level for controller input and SCR inputs (see figure 7).

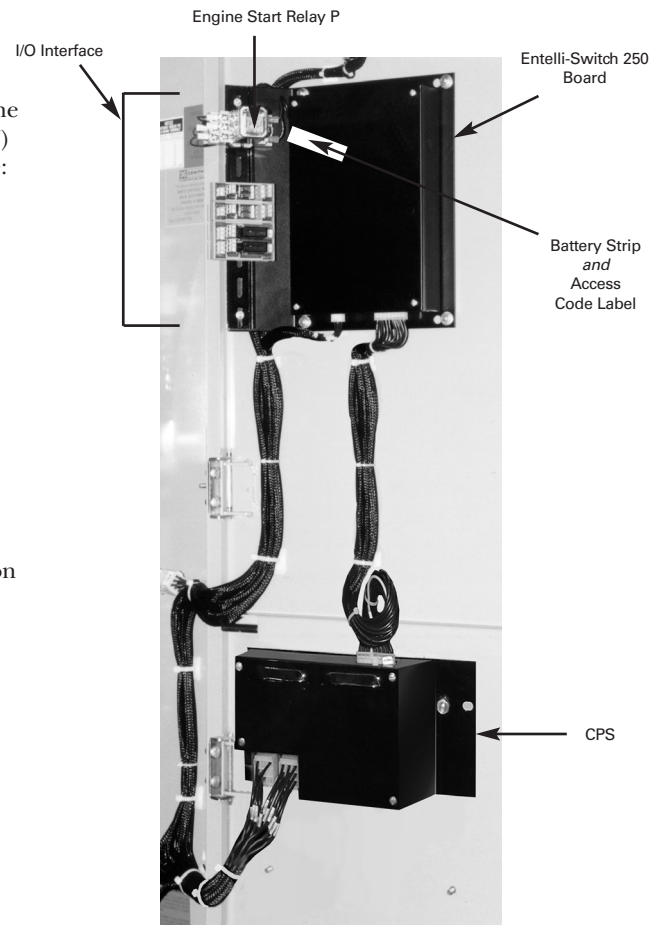

Figure 7

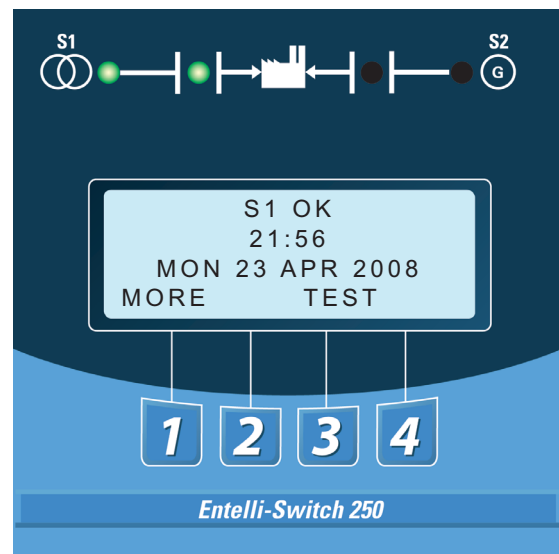

Figure 8

Entelli-Switch 250 Controller (cont'd)

LCD & Keypad

These options are accessible through the LCD and keypad (see figure below). To become familiar with the options loaded into a particular unit, scrolling through the SET and CFG menu will show the descriptions of the options (see pages 16-17). These menus are the very same menus that are used to access the setting and/or configuration of these options. The SET (setting) menu is primarily used to show or change, time and voltage settings. The CFG menu is primarily used to turn an option on or off. When scrolling through these menus, no changes can be made without entry of the access code. The factory set six-digit access code is located on a white label on the back of the unit (see figure 11 pgs. 16-18).

The Entelli-Switch 250 has many logic options. Each controller is downloaded with options at the time of manufacture. The collection of options that any one controller has is specified at the time of order placement. The following pages include all the options that can reside in the controller. Not all units include all options.

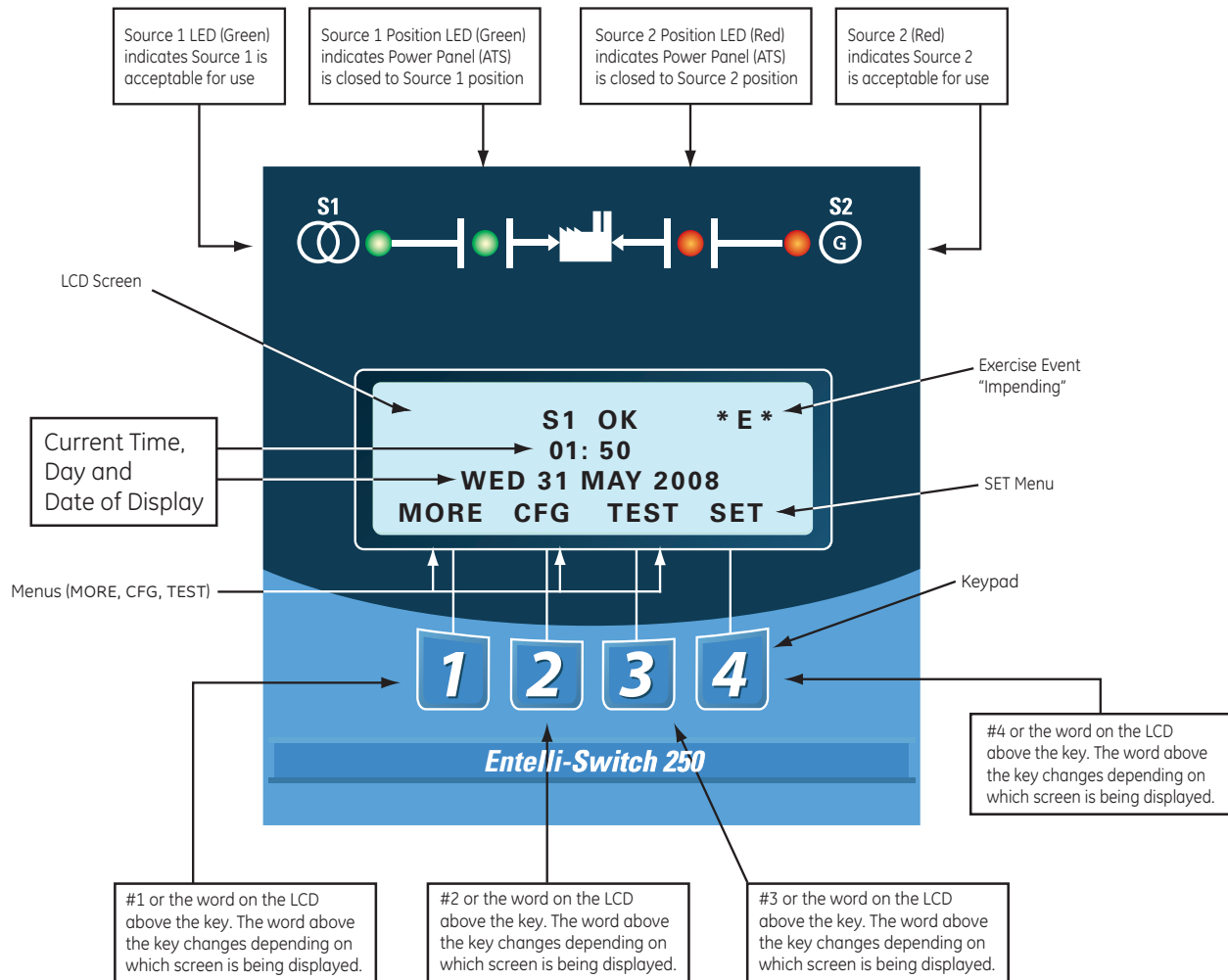

Figure 9

User Setting for Voltage & Frequency

Standard 3-Phase Sensing on 3 and 4 Pole Units

Source 1

Under Voltage “Restore”

Factory Default: 90%

This adjustment determines the minimum acceptable voltage required to transfer to Source 1. Adjust via the SET menu. Range is 85% to 100% in 1% increments (see page 17). Once satisfied, the T timer will begin timing to transfer to Source 1.

Under Voltage “Fail”

Factory Default: 80%

This adjustment determines the low voltage threshold. Adjust via the SET menu. Range is 75% to 98% in 1% increments (see page 17). “Fail” must be a minimum of 2% below “Restore” setting. Once voltage falls below threshold, P timer begins timing to signal Source 2 Generator to start.

Under Frequency “Restore”

Factory Default: 95%

This adjustment determines the minimum acceptable frequency required to transfer to Source 1. Adjust via the SET menu. Range is 90% to 100% in 1% increments (see page 17). Once satisfied, the T timer will begin timing to transfer to Source 1.

Under Frequency “Fail”

Factory Default: 90%, (5 seconds minimum)

This adjustment determines the low frequency threshold. Adjust via the SET menu. Range is 88% to 98% in 1% increments (see page 17). “Fail” must be a minimum of 2% below “Restore” setting. Once satisfied, the T timer will begin timing to transfer to Source 1.

Over Frequency “Restore”

Factory Default: 102%

This adjustment determines the minimum acceptable Over Frequency threshold at which the transfer switch is allowed to re-transfer to Source 1. Adjust via the SET menu. Range is 102% to 104% in 1% increments (see page 17). “Restore” must be a minimum of 1% below “Fail” setting.

Over Frequency “Fail”

Factory Default: 105%

This adjustment determines the maximum acceptable Over Frequency. Adjust via the SET menu. Range is 103% to 105% in 1% increments (see page 17). Once exceeded, the P timer begins timing to signal the generator to start.

Source 2

Under Voltage “Restore”

Factory Default: 90%

This adjustment determines the minimum acceptable voltage required to transfer to Source 2. Adjust via the SET menu. Range is 85% to 100% in 1% increments (see page 17). Once satisfied, the W timer will begin timing to transfer to Source 2.

Under Voltage “Fail”

Factory Default: 80%

This adjustment determines the low voltage threshold. Adjust via the SET menu. Range is 75% to 98% in 1% increments (see page 17). “Fail” must be a minimum of 2% below “Restore” setting. Once voltage falls below threshold, T timer will be bypassed to expedite the transfer to Source 1.

Over Voltage “Fail”

Factory Default: 110%

This adjustment determines the maximum acceptable Over Voltage. Adjust via the SET menu. Range is 105% to 110% in 1% increments (see page 17). Once exceeded, the T timer will be bypassed to expedite the transfer to Source 1.

Over Voltage “Restore”

Factory Default: 105%

This adjustment determines the minimum acceptable Over Voltage threshold at which the transfer switch is allowed to transfer to Source 2. Adjust via the SET menu. Range is 103% to 105% in 1% increments (see page 17). “Restore” must be a minimum of 2% below “Fail” setting.

Under Frequency “Restore”

Factory Default: 95%

This adjustment determines the minimum acceptable frequency required to transfer to Source 2. Adjust via the SET menu. Range is 90% to 100% in 1% increments (see page 17). Once satisfied, the W timer will begin timing to transfer to Source 2.

Under Frequency “Fail”

Factory Default: 90%, (5 seconds minimum)

This adjustment determines the low frequency threshold. Adjust via the SET menu. Range is 88% to 98% in 1% increments (see page 17). “Fail” must be a minimum of 2% below “Restore” setting. Once satisfied, the W timer will begin timing to transfer to Source 2.

Over Frequency “Fail”

Factory Default: 105%

This adjustment determines the maximum acceptable Over Frequency. Adjust via the SET menu. Range is 103% to 105% in 1% increments (see page 17). Once exceeded, the T timer will be bypassed to expedite the transfer to Source 1.

Over Frequency “Restore”

Factory Default: 102%

This adjustment determines the minimum acceptable Over Frequency threshold at which the transfer switch is allowed to re-transfer to Source 2. Adjust via the SET menu. Range is 102% to 104% in 1% increments (see page 17). “Restore” must be a minimum of 1% below “Fail” setting.

Accessory Group Packages

Table 3

Accessories	Group Packages					
	STDS	EXES	CONS	SENS	SPES	PSGS
6P	●	●	●	●	●	●
A1	○	●	●	●	●	●
A1E	○	●	●	●	●	●
A3	●	②	②	②	②	③
A4	●	②	②	②	②	③
Calibrate	●	●	●	●	●	●
CDT	●					
CDP		●	●	●	●	●
**DS	●	●	●	●	●	●
*DT	●	●	●	●	●	●
*DW	●	●	●	●	●	●
E	●	●	●	●	●	●
EL/P	●	●	●	●	●	●
K/P	●	●	●	●	●	●
L1	●	●	●	●	●	●
L2	●	●	●	●	●	●
L3	●	●	●	●	●	●
L4	●	●	●	●	●	●
*LN	●	●	●	●	●	●
P1	●	●	●	●	●	●
Q2	○	●	●	●	●	●
Q3	○	○	●	○	●	●
Q7	○	○	●	●	●	●
R1-1	○	○	○	●	●	●
R1-3	○	○	○	●	●	●
R15	○	○	○	○	○	●
*R15D	○	○	○	○	○	●
R16	○	●	●	●	●	●
R50	●	●	●	●	●	●
S5P	◐	◐	◐		●	
S12P	◐	◐	◐	●		●
S13P	●	●	●	●	●	●
T	●	●	●	●	●	●
T3/W3	②	②	②	②	②	②
U	●	●	●	●	●	●
UMD	②	②	②	②	②	②
VI	●	●	●	●	●	●
W	●	●	●	●	●	●
YEN	●	●	●	●	●	●

- Standard Accessory included in the group package.
- Optional Accessory not included but can be added to group package.
- ◐ Optional Accessory. Can not be used with accessory having the same symbol.
- N/A
- ② Denotes an Accessory with 2 circuits as a standard.
- ③ Denotes an Accessory with 3 circuits as a standard.

** Optional for 40-400 Amp

Accessory Definitions

6P

Test Switch, Momentary

6A

Test Switch, Maintained Auto/Momentary Test

6AP

Test Switch, Maintained/Momentary utilizing keypad

6B

Test Switch, Maintained - Auto / Momentary - Test, Key Operated

6C

Test Switch, Maintained - Auto / Maintained - Test, Key Operated

A1

Auxiliary Contact, operates on Source 1 line failure.

A1E

Auxiliary Contact, operates on Source 2 line failure.

A3

Auxiliary Contact: Closed in emergency (Source 2) Additional Available (10 max.) and need to be specified.

A4

Auxiliary Contact: Closed in normal (Source 1) Additional Available (10 max.) and need to be specified.

A62

Sequential Universal Motor Load Disconnect Circuit. Normally closed auxiliary contacts for motor loads. Open 0-60 seconds prior to transfer, after transfer, or both in either direction then re-close in timed sequence after transfer.

AB3

Auxiliary Contact: Closed in bypass emergency (Source 2) (S.P.D.T.) (Standard up to 400 Amp) Additional Available (10 max.) and need to be specified.

AB4

Auxiliary Contact: Closed in bypass normal (Source 1) (S.P.D.T.) (Standard up to 400 Amp) Additional Available (10 max.) and need to be specified.

B9

Battery charger connections.

Calibrate

While monitoring the actual Phase to Phase voltage levels and Frequency with a calibrated test equipment, the Phase to Phase voltage sensing and Frequency can be adjusted accordingly. Calibration capabilities are available for Frequency and AB, BC, CA Phase to Phase voltage for both Sources. Adjust via SET menu (see page 18)

CDP

Clock Exerciser Load/ No Load: Allows the Generator to start and run unloaded or to simulate a power failure, start Generator and run under load. Can be configured by end user for 1, 7, 14, 28, 365 day cycle. (See page 16)

CDT

Load or NO-Load. One event exerciser with adjustable Engine exercise timer. Exercise duration can be set between 5 and 60 minutes in 1 minute increments. Can be configured to run every 1, 7, 14, or 28 days. Factory Default is 20 minutes. When exerciser is impending, (*E*) appears in the upper right hand corner of LCD screen. See page 14 for instructions. Configured via CFG (see page 17). Set via SET menu (see page 18).

CTAP

Alarm Panel on transfer to Source 2 with Silence button.

DS

Disconnect Switch, Auto/Inhibit. Inhibits transfer in either direction when in inhibit. Allows automatic operation when in Auto. (40-400 Amps optional, 600-4000 Amps standard)

DT (Delayed Transition Only)

Time Delay from Neutral Switch position to Source 1 position. Adjustable 0-10 minutes in 1 second increments. Standard setting is 5 seconds Adjust via SET menu (see page 18)

DW (Delayed Transition Only)

Time Delay from Neutral Switch position to Source 2 position. Adjustable 0-10 minutes in 1 second increments. Standard setting is 5 seconds. Adjust via SET menu (see page 18)

E

Engine Start Contact

EL/P

Event Log: Sequentially Numbered Log of 16 events that track date, time, reason and action taken
System Data: Total Life Transfers (N2P)
Days Powered Up
Total Transfers to S2
Total S1 Failures
Time S1 available in Hrs
Time S2 available in Hrs. (N1P)

F

Fan contact, operates when generator is running.

HT

Heater and Thermostat

K

Frequency Meter, Door mount.

K/P

Frequency Indication for S1 and S2

L

LNP Center-off position LCD-Indicator

Indicating LED lights:

- L1 Indicates Switch in Source 2 position.
- L2 Indicates Switch in Source 1 position.
- L3 Indicates Source 1 available.
- L4 Indicates Source 2 available.

Accessory Definitions *(cont'd)*

M1

Single Phase Amp Meter

M2

Three Phase Amp Meter

M80

3000 Digital Power Monitor

M82

5200 Digital Power Meter

M83A

EPM 5300 Digital Power Meter with Modbus Port

M83B

EPM 5350 Digital Power Meter with Ethernet Port

M84

7430 Digital Power Meter , Wye or Delta

M85A

EPM 9450 Digital Power Meter, Ethernet

M85B

EPM 9450 Digital Power Meter with Internal 56K Mod.

M86A

EPM 9650 Digital Power Meter, Wye or Delta, RS232 or RS485

M86B

EPM 9650 Digital Power Meter, Wye or Delta, RS232 or RS485

N1

Running Time Meter, Door mount

N2

Operation Counter, Door Mount

P1

Time Delay Source 2 Start. Adjustable 0-10 seconds. Standard setting is 3 seconds. Adjust via SET menu (see page 18)

P2

Time Delay S2 Start. Adjustable 1/6 to 300 seconds.

Q2

Remote Peak Shave or Area Protection Circuit. Energize Q2 to simulate Source 1 Line failure causing the Generator to start and transfer the load to Source 2. Should Emergency fail during this operation, Transfer Switch will retransfer back to Source 1.

Q3

Remote inhibit transfer to Source 2 circuit. Energize Q3 input to allow transfer to Source 2. To enable Q3 option, engage Q3 jumper.

Q7

Inhibit transfer to Source 1 circuit. Energize Q7 input to prevent transfer to Source 1.

R1-1/R1-3

Source 1 Over Voltage sensing for single and three phase systems.

Source 1 Over Voltage "Fail"

Factory Default: 110%

This adjustment determines the maximum acceptable over voltage. Adjust via the SET menu. Range is 105% to 110% in 1% increments (see page 18). Once exceeded, the P timer begins timing to signal the Generator to start.

Source 1 Over Voltage "Restore"

Factory Default: 105%

This adjustment determines the minimum acceptable over Voltage threshold at which the Transfer Switch is allowed to automatically transfer to Source 1. Adjust via SET menu. Range is 103% to 108% in 1% increments. "Restore" must be a minimum of 2% below "Fail" setting (see page 18).

R15/R15D

Load Shed

Should Source 2 become overloaded, a signal can be given to switch to the dead or Mid position.

R16

Phase Rotation Sensing

Can be turned on or off via CFG menu (see page 17).

Factory Default is on.

This feature prevents Line Source to Line Source transfers from occurring between dissimilar phase sequences. This condition is primarily caused by an installation error. Connections from Source 1 and Source 2 need be verified, compared, and corrected to remedy the inconsistent phase rotation between the sources. **WARNING:** Turning off this feature can cause severe damage to loads.

R26

Interruptable Power Rate Provisions. Allow transfer out of Source 1 position to Source 2 or dead Source 2. Alarm and Pre-Signal circuit included.

Accessory Definitions *(cont'd)*

R50

In Phase Monitor this feature restricts **Live to Live Source Transfers** to occur unless both Sources are within 7 electrical degrees or less of each other. (live Source to live Source transfers usually occur during transfer back to Source 1 or during Testing). R50 does not change the operation of the Automatic Transfer Switch in a power failure mode. After all timer functions have elapsed, the **CHECKING FOR SOURCE SYNCHRONISM** will be displayed as well as the direction of transfer (S1-S2 for example denotes transfer from Source 1 to Source2). When synchronism is accomplished, transfer will take place.

- Notes:**
- If S2 Frequency is less than S1 Frequency, display will show a series of (- - - - -) symbols.
 - If S2 Frequency is greater than S1 Frequency, display will show a series of (+ + + + +) symbols.
 - Each (-) or (+) symbol represents 10 electrical degrees out of phase. A maximum of 18 symbols (180 electrical degrees) can be monitored.
 - The number of (-) or (+) symbols decrease as the two sources approach synchronism and increase as the two sources drift out of synchronism.
 - If S1 and S2 Frequencies are identical, the display will show a series of alternating symbols (±±±±...) which also indicate the approximate out of phase degrees

In the event that the Sources do not come within 7 electrical degrees of each other within 60 seconds, the unit will display the message: **SYNCH CHECKING** and will allow the user to **BYPASS**. If the **BYPASS** button is pressed, the unit will display the message: **WARNING MAY CAUSE DAMAGE TO THE LOAD**. Pressing **XFR** will actually bypass the R50. Since R50 is a passive device, the length of time it takes to reach Synchronism is dependent on the frequency difference between the two Sources. Source 1 is usually a Utility and the frequency is not within the control of the consumer. Source 2 needs to be adjusted to create an adequate difference in order for the transfer to happen a timely fashion.

Note: For optimum performance, Source 2 Generator should be adjusted a Maximum of 2 Hertz above or below the Utility frequency, minimum of 0.1 Hertz. (58 to 59.9) or (60.1 to 62) Hertz. Adjustment of Generator to 60Hertz could cause lengthy transfer delay.

R50 Feature can be turned ON or OFF via CFG Menu (see page 17). Factory Default if OFF.

S5P

Auto / Semi Manual selector

In "Auto" position, retransfer to Source 1 is automatic after the T timer has timed out. The T time delay is bypassed if Source 2 fails.

In "Manual", retransfer to Source 1 is upon depression of **BYPASS DELAY** button YEN or if Source 2 fails.

S12P

Auto / Manual Selector

In "Auto" position, the Automatic Transfer Switch functions automatically as specified with the Switch drawings. In "Manual" the Automatic Transfer Switch will transfer to either direction upon depression of Source 1 or Source 2 transfer buttons. Should Source 1 fail, the Generator (Source 2), will automatically start. Once transferred in Manual, the Switch maintains position selected even if selected power fails.

S13P

Transfer Commit. Configured via CFG menu. (see page 17) When this Feature is set to OFF: The transfer Switch is not committed to transfer unless the outage duration is longer than the timers that precede the transfer to Source 2 position. This assumes that the outage will be an isolated event. When this Feature is set to ON: The transfer Switch is committed to transfer to Source 2 position once the W timer has begun timing, even if Source 1 power returns before the transfer to Source 2. This is to ensure that the transfer takes place, because one outage may be followed by another.

S14

Test / Auto / Source 1 Selector, Door mount

SW1

Auto/Off/Start Engine control selector, Door mount (Keyed or non-keyed operation available)

SW2

Auto / Off Engine control selector, Door mount (Keyed or non-keyed operation available)

SW3

Source Priority Selector Switch, Door mount Allows selection of Source 1 or Source 2 to be the Prime Source. Transfer Switch will transfer to selected Prime Source if that Source is available. (Keyed or non-keyed operation available)

T

Time Delay (S1) Source 1 Stable Timer. To delay transfer to Source 1 (immediate retransfer on Source 2 failure). Adjustable 0-60 minutes in 1 second increments. Standard setting is 30 minutes. Adjust via SET menu (see page 18)

T3/W3

Elevator Pre-Signal Auxiliary Contacts: Open 0-60 seconds prior to transfer to either direction, re-closes after transfer.

U

(S2) Source 2 Stop Delay Timer. Allows Engine to run unloaded after switch retransfer to Source 1. Adjustable 0-60 minutes in 1 second increments. Standard setting is 5 minutes. Adjust via SET menu (see page 18)

Accessory Definitions *(cont'd)*

UMD

Universal Motor Load Disconnect Circuit: Auxiliary Contact opens 0-60 seconds prior to transfer in either direction, re-closes after transfer. Can be configured by end user for Pre-transfer, Post-transfer, or both.

VI

Voltage Imbalance (Three Phase)

For a three phase source, this feature monitors phase voltage ratios based on a selected range within a selected time window. Should any phase fall below the selected lower window limit or exceed the selected higher window limit within the selected time frame, the controller initiates transfer to the other source.

Range: 5% to 20% of Nominal voltage,
10 to 30 seconds window, user adjustable.

Resolution: 1% Increments

Minimum Differential: 2% between "Fail"
and "Restore" settings.

Factory default: 10% "Fail", 8% "Restore", 30 Seconds.

See CFG Menu page 17 to configure ON or OFF.

See SET Menu page 18 to set Percentage and time windows

W

Time Delay (S2) Source 2 Stable Timer. To delay transfer to Source 2. Adjustable 0-5 minutes in 1 second increments. Standard setting is 1 second. Adjust via SET menu (see page 18)

YEN

Bypass Timers Key utilizing Keypad. When applicable, the system prompts the user to press a button to bypass (T) or (W) Timers should the user so desires.

ZNET

Network Communications Interface Card

How to Set the System Clock

How to Set the System Clock

Set System Clock, time and date

- If the clock is not set, the display will show SET SYSTEM CLOCK on the second line of the S1 OK screen.
- The S1 OK screen will show time (hours and minutes) on the second line if the system clock has been set. (Date on third line)

Setting the System Clock

(Start from S1 OK screen)

1. Remove battery protective white plastic strip near P relay. *
2. Press MORE then press SET.
3. Press MORE and scroll to SET SYSTEM CLOCK using the MORE key.
4. Press SEL.
5. ENTER ACCESS CODE located on the white label on the back of the controller.
6. Press SEL.
7. Use the up and down keys to change the hour value.
8. Press SAVE (this will enter this value and move cursor to minutes).
9. Use the up and down keys to change the minutes.
10. Press SAVE (this will enter this value and move cursor to month).

11. Use the up and down key up to change the month.
12. Press SAVE (This will enter this value and complete the clock setting).
13. Use the up and down keys to change the date.
14. Press SAVE (this will enter this value and move cursor to year).
15. Use the up and down keys to change year.
16. Press SAVE (this will enter this value and complete the clock setting).
17. To edit settings, press SEL and repeat steps 6-16.
18. If the setting is satisfactory, press MORE (unit then returns to the SET menu then press BACK, then ESC)

- * Replacement battery part #K-4100
Battery will last 5 years and provides power to retain clock function only (Controller functions without battery).

CDT One Event Timer Exerciser

Load / No-Load

One event Exerciser with adjustable Timer. Exercise duration can be set between 5 and 60 minutes in 1 minute increments. Can be configured to run every 1,7,14, or 28 days. Factory default is 20 minutes.

How to CONFIGURE (CFG) and Set (SET) the Timer Exerciser

1. Beginning from the **S1 OK** screen, press **MORE** then **CFG**.
2. Press **MORE** to scroll to **CONFIG TIMER EXERCISER** screen.
3. The third line of the **CONFIG TIMER EXERCISER** will show either **DAILY**, **WEEKLY**, **14 DAY**, **28 DAY**, or **OFF**.
4. If the third line of the **CONFIG TIMER EXERCISER** shows **DAILY**, **WEEKLY**, **14 DAY**, or **28 DAY** as desired, then proceed to step 10.
5. If the third line of the **CONFIG TIMER EXERCISER** shows **OFF** or if another timer selection is desired, continue.
6. Press **SEL**.
7. Enter **ACCESS** code located on white label on the back of the controller.
8. Press **UP** or **DOWN** to select **DAILY**, **WEEKLY**, **14 DAY**, or **28 DAY** as desired.
9. Press **SAVE**.
10. Press **MORE** to scroll to **CONFIG TIMER EXERCISER (XFR)** or **(NO XFR)**.
11. Press Up or Down to select **XFR** (Load Transfer) or **NO XFR** (No Load Transfer).
12. Press **SAVE**.
13. Press **MORE** repeatedly to **BACK** then **S1 OK** screen.

Set (SET) the Exerciser:

14. Beginning from the **S1 OK** screen, press **MORE** then **SET**.
15. Press **MORE** repeatedly until **EXER S2 RUN TIME** screen.
16. Press **SEL**.
17. Enter **ACCESS** code located on white label on the back of the controller.
18. Press **SEL**.
19. Cursor is indicated as a line under character to be changed. Change values with up and down keys.
20. Press **SAVE** when complete.
21. Press **MORE** repeatedly until **SET USER SETUP** then press **BACK** then **ESC** to the **S1 OK** screen.

How to Initiate CDT Exerciser and to start an exercise cycle every 1, 7, 14, or 28 days

From S1 screen

- 1) Press **TEST**
- 2) Press **MORE**
- 3) Press **START TEST TIMER** (to initiate Test).

- If the CDT Exerciser is Factory configured for a Load Exerciser, the Controller will immediately start a load exercise. The controller will start the generator, transfer the load to Source 2 and remain in Source 2 for the duration set for **EXER S2 RUN TIME** in the **SET** menu. The controller will retransfer the load back to Source 1 after the S1 stable timer has timed out and run the generator unloaded for the duration of the S2 stop delay timer (Engine Cool Down Timer).
- If the CDT Exerciser is Factory configured for a No-Load Exerciser, the Controller will immediately start a No-load exercise. The controller will start the generator and run it unloaded for the duration of the S2 stop delay timer (Engine Cool Down Timer).

Exercise will be repeated at the same time as initiated on every 1, 7, 14, or 28 days according to the selection made in the Configure **CFG** menu.

How to Bypass (Cancel) an exercise during an exercise cycle

- 1) Press **BPASS**
- 2) Allow the controller to complete the Engine cool down cycle

If the CDT Exerciser is Factory configured for a No-Load Exerciser or allow the controller to complete retransfer to Source 1 If the CDT Exerciser is Factory configured for a Load Exerciser

How to Bypass the next exercise event and Keep the rest of scheduled events unchanged

- 1) Press **TEST**
- 2) Press **MORE**
- 3) Press **BYPASS EXER**

To re-institute the next exercise event back, press **CANCL BPASS**

How to initiate a new exercise start time

- 1) Press **TEST**
- 2) Press **MORE**
- 3) Press **EXER CANCL**
- 4) Press **START TIMER TEST**

How to check the next exercise event

- 1) From **S1 OK** screen, press **MORE** three times.
- 2) The unit will display the **PLANT EXERCISER NEXT** event in **DAYS**, **HOURS**, and **MINUTES**
- 3) Press **ESC** to **S1 OK** Screen.

Notes:

- *E* appears in the upper right hand corner of LCD screen when exercise is impending.
- For Load Exerciser, actual exercise period (ATS in S2 position) = CDT (Exerciser) timing period +T (S1 stable Timer) timing period.

CDP Clock Exerciser

Load / No-Load Clock Exerciser

Allows the Generator to start and run unloaded or to simulate a power failure, start Generator and run under load. Can be configured by the end user for 1, 7, 14, 28, or 365 day cycles.

- A total of 7 independent No Load exercise periods (up to 10 hours each) can be programmed for each of the daily, weekly, 14-day, and 28-day exercisers.
- A total of 12 independent No Load exercise periods (up to 10 hours) can be programmed for the 365-day Exerciser.

How to Configure (CFG) the Exerciser

1. Beginning from the **S1 OK** screen, press **MORE** then **CFG**.
2. Press **MORE** to scroll to **CONFIG CLOCK EXERCISER** screen.
3. The third line of the **CONFIG CLOCK EXERCISER** will show either **DAILY**, **WEEKLY**, **14 DAY**, **28 DAY**, **365 DAY** or **OFF**.
4. If the third line of the **CONFIG CLOCK EXERCISER** shows **DAILY**, **WEEKLY**, **14 DAY**, **28 DAY**, or **365 DAY** as desired, press **MORE** repeatedly to **BACK**. Press **ESC** then proceed to the **SET** menu to set the **EXERCISER**.
5. If the third line of the **CONFIG CLOCK EXERCISER** shows **OFF**, continue.
6. Press **SEL**.
7. Enter **ACCESS** code located on white label on the back of the controller.
8. Press **UP** or **DOWN** to select **DAILY**, **WEEKLY**, **14 DAY**, **28 DAY**, or **365 DAY** as desired.
9. Press **SAVE**.
10. Press **MORE** repeatedly to **BACK** then **ESC** to **S1 OK** screen.

How to set (SET) the DAILY Exerciser

1. Beginning from the **S1 OK** screen, press **MORE** then **SET**.
2. Press **MORE** repeatedly until **SET EXERCISER** screen.
3. Press **SEL**.
4. Enter **ACCESS** code located on white label on the back of the controller.
5. Press **SEL**

6. Cursor is indicated as a line under character to be changed. Change values with up and down keys. Press **SAVE** after each entry to save value and to move to the next value to be changed.
7. Press **BACK** when complete.
8. Press **MORE** repeatedly until **SET USER SETUP**. Press **BACK** then **ESC** to the **S1 OK** screen.

How to Bypass (Cancel) an exercise during an exercise cycle

- 1) Press **BPASS**
- 2) Allow the controller to complete the Engine cool down cycle.

If the CD Exerciser is configured or Set for a No-Load Exercise. Or allow the controller to complete retransfer to Source 1. If the CD Exerciser is configured for a Load Exerciser

How to Bypass the next exercise event and Keep the rest of scheduled events unchanged

- 1) Press **TEST**
- 2) Press **MORE**
- 3) Press **BYPASS EXER**

To re-institute the next exercise event back, press **CANCL BPASS**

How to check the next exercise event

- 1) From **S1 OK** screen, press **MORE** three times.
- 2) The unit will display the **PLANT EXERCISER NEXT** event in **DAYS**, **HOURS**, and **MINUTES**
- 3) Press **ESC** to **S1 OK** Screen.

Notes:

- In the **S1 OK** screen, an (*E*) appears in the upper right hand corner of LCD screen when exercise is impending.
- For Load Exerciser, actual exercise period (ATS in S2 position)= **CDT** (Exerciser) timing period +T (S1 Stable Timer) timing period.
- A value greater than zero must be entered in the Exerciser duration field to be accepted as a valid exercise period.
- The Exercise cycle will be repeated on a regular basis as programmed and initiated in the **SET** menu depending on what Exerciser was configured (selected) in the **CFG** menu.

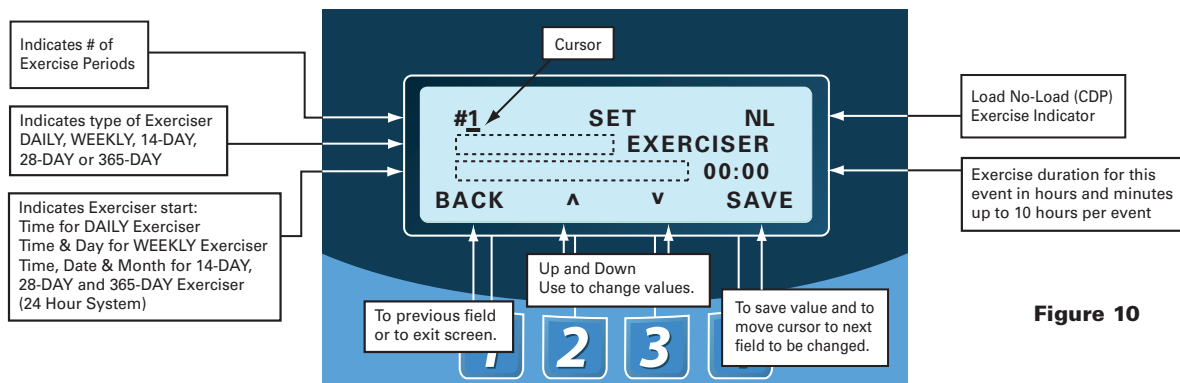
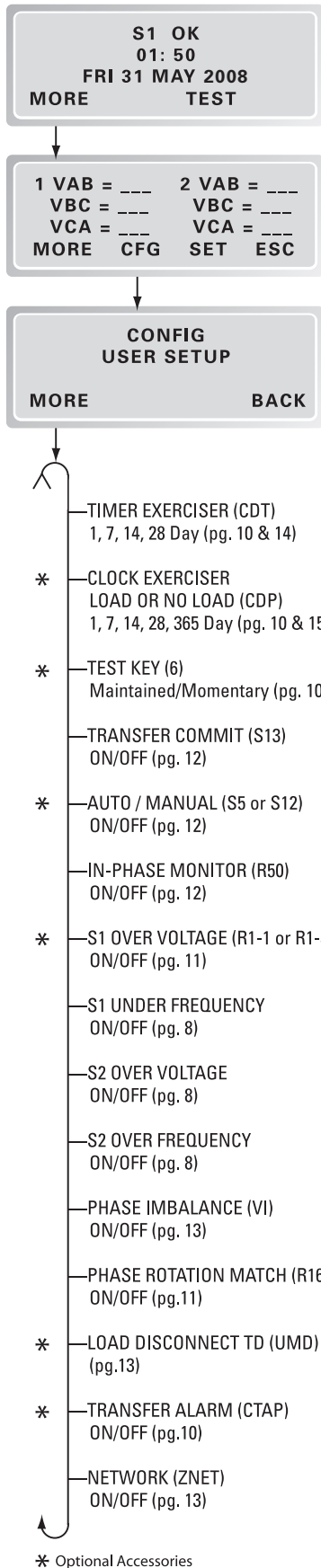

Figure 10

Entelli-Switch 250 User Setup - CFG Menu



Turn options ON or OFF via keypad through the CFG menu

Enter six digit access code
(The factory assigned six-digit access code is located on the back of the controller)

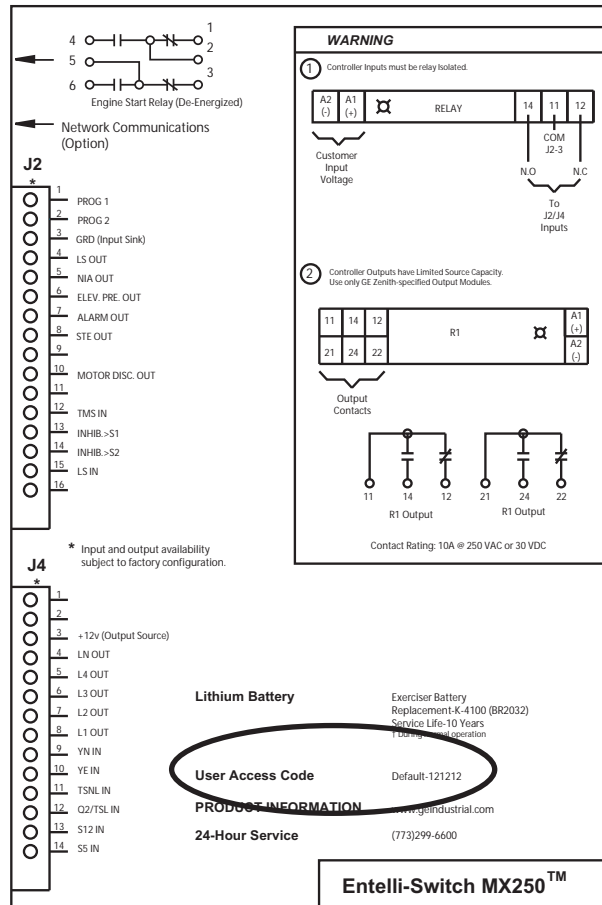

Figure 11

Entelli-Switch 250 User Setup - SET Menu

```

S1 OK
01: 50
FRI 31 MAY 2008
MORE      TEST
    
```

```

1 VAB = ___ 2 VAB = ___
VBC = ___ VBC = ___
VCA = ___ VCA = ___
MORE  CFG  SET  ESC
    
```

```

      SET
      USER SETUP
MORE      BACK
    
```

- SET SYSTEM CLOCK (pg.13)
- DAYLIGHT SAVINGS ON/OFF
- * — CLOCK EXERCISER (CDP) (pg.10 & 15)
- EXER S2 RUNTIME (CDT) (pg.10 & 14)
- S1 UNDER VOLTAGE (pg.8)
Fail
Restore
- S1 UNDER FREQUENCY (pg.8)
Fail
Restore
- * — S1 OVER VOLTAGE (pg.11)
Fail
Restore
- S1 OVER FREQUENCY (pg.8)
Fail
Restore
- S2 UNDER VOLTAGE (pg.8)
Fail
Restore
- S2 UNDER FREQUENCY (pg.8)
Fail
Restore
- S2 OVER VOLTAGE (pg.8)
Fail
Restore
- S2 OVER FREQUENCY (pg.8)
Fail
Restore
- SET % PHASE IMBALANCE (VI)
FAIL 5%, RESTORE 3% (pg.13)
- SET PHASE IMBALANCE (VI)
TIME DELAY 30 seconds (pg.13)

- TIME DELAY S2 START (P1) (pg.11)
- TIME DELAY S2 STABLE (W) (pg.13)
- * — LOAD PRESIGNAL TD (T3/W3) (pg.12)
- * — LOAD DISCONNECT TD (UMD) (pg.13)
- ATS OPEN TIME TO S2 (DW)
DELAY units only (pg.10)
- TIME DELAY S1 STABLE (T) (pg.12)
- ATS OPEN TIME TO S1 (DT)
DELAY units only (pg.10)
- S2 STOP DELAY (U) (pg.12)
- CALIBRATE S1 (pg.10)
- CALIBRATE S2 (pg.10)

* Optional Accessories

Change adjustable values through the SET menu.

Enter six digit access code
(The factory assigned six-digit access code is located on the back of the controller)

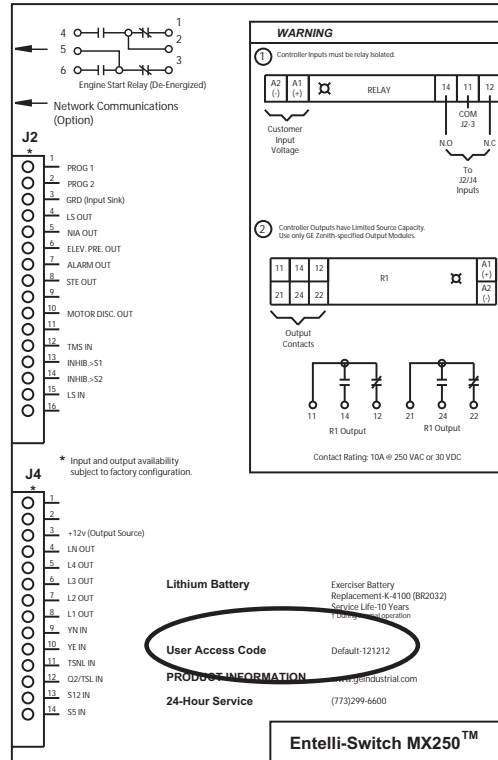

Figure 11

Entelli-Switch 250 User Setup - System Info

S1 OK
01: 50
FRI 31 MAY 2008
MORE TEST

- PHASE TO PHASE VOLTAGE, S1 & S2
- FREQUENCY INDICATION FOR S1 & S2 (K/P) (pg.10)
- PLANT EXERCISER:
Next Impending Exerciser (shows only if set)
- SYSTEM INFO:
 - Serial #: Unit Serial #
 - Rev #: Software Revision #
 - Event Log: Sequentially Numbered Log of 16 events that track date, time, reason and action taken
 - Data:
 - Total Life Transfers (N2P)
 - Days Powered Up
 - Total Transfers to S2
 - Total S1 Failures
 - Time S1 available in Hrs
 - Time S2 available in Hrs. (N1P)
- CHANGE USER ACCESS CODE

View System Data

Enter six digit access code
 (The factory assigned six-digit access code is located on the back of the controller)

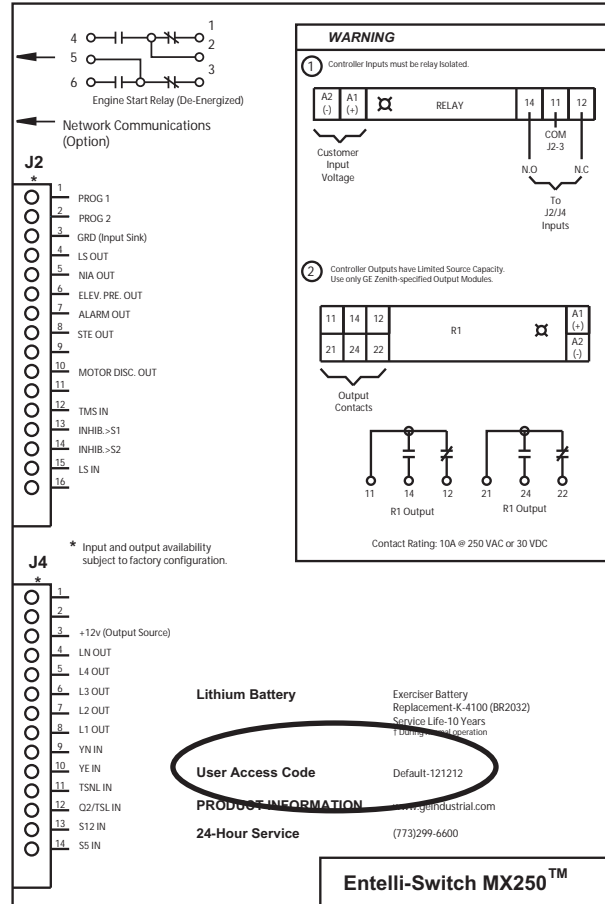

Figure 11

Testing

⚠ CAUTION ⚠

Due to hazardous voltage and current, GE Zenith recommends that a GE Zenith Certified technician or a qualified electrician must perform the installation and maintenance of the switch.

⚠ WARNING ⚠

Both power sources must be disconnected before manual operation of the switch.

Introduction

A manual operator handle is provided with the transfer switch for maintenance purposes only. Manual operation of the switch must be checked before it is operated electrically. **Both power sources must be disconnected before manual operation of the switch.** Insert the handle and operate the transfer switch between the Source 1 and Source 2 positions. The transfer switch should operate smoothly without binding. Return the switch to the Source 1 position, remove the handle, and return it to the holder provided.

After completing the inspection, cleaning and servicing of the transfer switch, reinstall the switch cover, and close and lock the cabinet door. Reclose the circuit breakers feeding the utility and generator sources to the switch.

Initiate the electrical transfer test by activating the test switch. P timer will time out and the microcontroller will send an engine start signal. When the W time has elapsed, the switch will complete its transfer by closing into the Source 2.

Deactivating the test switch will start retransfer to Source 1. The switch will complete its retransfer to Source 1 after the time delay of the T timer. The U engine overrun timer allows the engine generator to run unloaded for a pre-set cool down period.

Test Options

The ATS can be tested in either of two positions:

1) “Auto Position”

Full Transfer Test - This test checks the complete operation of the ATS by transferring the load's power source from Source 1 to Source 2.

2) “Test Position”

This procedure is recommended for Preventive Maintenance (PM) of ATS without interrupting the Load thru the BYPASS/ISOLATION SWITCH.

NOTE: A periodic test of the transfer switch under load conditions is recommended to insure proper operation. (See National Electric Code articles 700 and 701).

⚠ WARNING ⚠

When performing a hi-pot or dielectric test on the power section, **DISCONNECT** the control panel plugs from the microprocessor to avoid potential damage.

⚠ NOTICE ⚠

A periodic test of the transfer switch under load conditions is recommended to insure proper operation. (See National Electric Code articles 700 and 701)

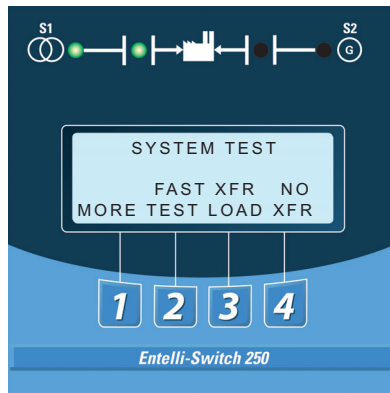

Figure 12

ATS Testing

Start generator and verify proper voltage, frequency and phase sequence (match to Source 1). Shut down gen set and place in Auto. Complete the visual inspection of the transfer switch, and close the cabinet door.

Initiate the test by pressing the TEST button on the LCD keypad. The controller will then prompt for your access code. After entering the code, three test options will appear—XFR LOAD, FAST TEST and NO XFR (See Figure 12).

- **XFR LOAD** test starts the generator and using the current timer settings, transfers the load to Source 2.
- **FAST TEST** test presets timer values to a maximum 30 seconds during the test. After completion of the test, all timers are reset to their original values. (T3, W3, DT and DW remain)
- **NO XFR** test starts the generator but does not transfer the load to the Source 2.

Press and hold the desired test option button until the switch transfers to Source 2 (load test) or until the generator has been run for the desired amount of time (no load test). Releasing the test button before W timer timeout will abort the test (Exception: when the transfer commit option, is configured “ON”).

To test lamps, press TEST then scroll through MORE, then press LAMP TEST. To cancel LAMP TEST press MORE.

Open Transition

Source 1 Power Failure:

When a Test is initiated, the controller initiates the Time Delay Source 2 Start (Engine Start Timer “P”) cycle. Upon completion of the (P) time delay, an Engine start Signal is sent to Source 2. When Source 2 voltage and frequency reach the preset “Restore” values, the time delay to open Source 1 timer (W) begins its timing cycle to ensure voltage and frequency stabilization before re-transfer. A manual pushbutton BYPASS is provided to bypass the “W” time delay if desired. After the (W) time delay, the MX controller initiates a transfer signal through the SCR-NO to operate the main transfer operator. The load is now transferred to the Open position. The time delay to Source 2 timer (DW) begins its timing cycle. After the (DW) time delay, the MX controller initiates a transfer signal through the SCR-E to operate the main transfer operator. The load is now transferred to Source 2 line. The transfer switch is mechanically locked. SN limit switch awaits the next operation to Source 1.

Restoration of Source 1 Power:

Deactivating the Test switch initiates the re-transfer. When Source 1 power reach the preset “Restore” values, the controller initiates re-transfer to Source 1 sequence. The delay to open Source 2 Timer (T) begins its timing cycle to ensure voltage and frequency stabilization before retransfer. A manual pushbutton BYPASS is provided to bypass the “T” time delay if desired. After the (T) time delay, the MX controller initiates a transfer signal through the SCR-EO to operate the main transfer operator. The load is now transferred to the Open position. The time delay to Source 1 timer (DT) begins its timing cycle. After the (DT) time delay, the MX controller initiates a transfer signal through the SCR-N to operate the main transfer operator. The load is now transferred to Source 1 line. The transfer switch is mechanically locked. SE limit switch awaits the next operation to Source 2.

Immediately after re-transfer, the S2 Stop Delay Timer (Delay to Engine Stop “U”) begins its cycle to allow Source 2 Engine to run unloaded. A manual pushbutton BYPASS is provided to bypass the “U” time delay if desired. Upon completion of the (U) timing cycle, the controller sends an Engine stop signal.

⚠ NOTICE ⚠

A periodic test of the transfer switch under load conditions is recommended to insure proper operation. (See National Electric Code articles 700 and 701)

Closed Transition

GE Zenith Closed Transition Transfer Switches are designed to Transfer the Load between two available sources without interrupting power to the Load (Make-Before-Break). Paralleling of the two sources occurs within a predefined window of synchronization and lasts less than 100 milliseconds. The initial Source is then disconnected.

Initiating a Closed Transition

When a Test is initiated, the controller initiates the Time Delay Source 2 Start (Engine Start Timer “P”) cycle. Upon completion of the (P) time delay, an Engine start Signal is sent to Source 2. When Source 2 voltage and frequency reach the preset “Restore” values, the time delay to open Source 1 timer (W) begins its timing cycle. After the (W) time delay, the ATS closes into Source 2 only after the controller ensures the proper phase relationship between the two Sources. After the ATS closes into Source 2, the SE limit switch becomes activated. The controller initiates a transfer signal through the SCR-NO which opens the ATS out of Source 1. The SNO limit switch activates. The ATS has now closed into Source 2 position without interrupting the load.

Retransfer with Closed Transition

Deactivating the Test Switch initiates the re-transfer. When Source 1 voltage and frequency reach the preset “Restore” values, the time delay to open Source 2 timer (T) begins its timing cycle. After the (T) time delay, the ATS closes into Source 1 only after the controller ensures the proper phase relationship between the two Sources. After the ATS closes into Source 1, the SN limit switch becomes activated. The controller initiates a transfer signal through the SCR-EO which opens ATS out of Source 2. The SEO limit switch activates. The ATS has now closed back into Source 1 position without interrupting the load.

The ATS defaults to an open transition transfer when Source 1 fails. Closed transition transfer is not possible with only one source available. If the optional Transition Mode Selector (TMS) is available, one can select an Open Transition Transfer or a Closed Transition Transfer when both Sources are available.

If while in Closed Transition Mode, the ATS fails to open the source it is attempting to “transfer out of” within 100 milliseconds, an Alarm will sound and the source that the ATS just closed into will be opened leaving the ATS in its initial source while disabling all other transfer operations until the problem is corrected and the “Fail to Open Lockout Reset” has been pressed.

A signal will be provided (STE) to Shunt Trip the Generator Circuit Breaker if the Transfer Switch remains closed into both Sources for more than 325 milliseconds. The load will then be fed by the Source 1. The maximum time that the two Sources would be parallel, under these conditions, is less than 500 milliseconds. Before operating the Closed Transition Transfer Switch, the condition must be corrected and the Shunt Trip reset. Refer to procedure for servicing the Switch after Shunt Tripping occurs.

The unit is Factory set to accomplish transfer within 5 electrical degrees.

Requires an Isochronous Governor with an operating frequency of 60+/- 0.2 Hz.

Requires a Shunt Trip Breaker on the Generator set with a response time not exceeding 50 milliseconds.

⚠ DANGER ⚠

HAZARDOUS VOLTAGE (Can Cause Severe Injury or Death)

Turn OFF all power before installation, adjustment, or removal of transfer switch or any of its components.

Emergency Service Procedure for Extended Parallel Time

ZTSCT Transfer Switch

If Source 2 breaker shunt trip was triggered after an extended parallel time (malfunction) occurred. Follow these steps to open the transfer switch.

- 1) Disconnect all power sources from the transfer switch by opening all line breakers (Source 1 and Source 2).
- 2) Open the cabinet door and turn the disconnect switch to the INHIBIT position.
- 3) Remove the service access cover on the left hand side of the transfer switch.
- 4) The manual operator and the manual handle will now be exposed. Insert the handle into Source 2 side operator. Open Source 2 side contacts.
- 5) Close the cabinet door.
- 6) Energize Source 1 to supply the load until further repairs can be done.

ZBTSCT Transfer/Bypass Switch

a. Auto Location:

Removal of closed transition transfer switch after Source 2 breaker shunt trip.

- 1) Disconnect all power sources from bypass-isolation transfer switch.
- 2) Open the bottom cabinet door and turn the Disconnect Switch (DS) to the INHIBIT position.
- 3) Remove the service access cover on the left hand side of the transfer switch.
- 4) The manual operator and the manual handle will now be exposed. Insert the handle into Source 2 side manual operator. Open Source 2 side contacts.
- 5) Close bottom cabinet door.
- 6) Energize Source 1 power.
- 7) Close the bypass contacts (BN).*
- 8) Isolate the transfer switch.*
- 9) Remove the transfer switch from the bypass-isolation transfer switch as indicated on the bypass instruction label to inspect and repair.
- 10) Re-install the transfer switch after maintenance with contacts closed to the same source as the bypass switch. Reinstall the manual handle in its holder and the service access cover on the left side of the transfer switch.
- 11) Re-connect the transfer switch to AUTO.*

b. Auto Location:

Removal of the closed transition transfer switch if Source 1 and Source 2 contacts remain open.

- 1) Close the bypass switch into the available source.*
- 2) Turn the DS to INHIBIT. Remove the transfer switch service access cover. Close the transfer switch into the same source as the bypass switch. (Incorrect sequencing is prevented by the interlocks while the transfer switch is in AUTO only.)
- 3) Remove the transfer switch from the bypass-isolation transfer switch to inspect and repair.*

c. Test Location:

Removal of the closed transition transfer switch if both Source 1 and Source 2 contacts remain open.

- 1) Close the bypass switch contacts (BN) as indicated on the bypass instruction label on the cabinet door.
- 2) Disconnect all power sources from bypass-isolation closed transition transfer switch.
- 3) Open bottom cabinet door. Turn the Disconnect Switch (DS) to the INHIBIT position.
- 4) Remove the service access cover on the left side of the transfer switch.
- 5) The manual operator and the manual handle will not be exposed. Insert the handle into Source 1 side and close Source 1 contacts.
- 6) Close the bottom cabinet door.
- 7) Energize Source 1 power.
- 8) Remove the automatic transfer switch from the bypass-isolation transfer switch.*
- 9) Re-install the transfer switch after maintenance with contacts closed to the same source as the bypass switch. Reinstall the manual handle in its holder and the service access cover on the left side of the transfer switch.
- 10) Re-connect the transfer switch to AUTO.*

* As described in the following Sequence of Operation in this manual.

Sequence of Operation

Open Transition

Source 1 Power Failure:

When Source 1 voltage or frequency has fallen below the preset “Fail” values, the controller initiates the Time Delay Source 2 Start (Engine Start Timer “P”) cycle. Upon completion of the (P) time delay, an Engine start Signal is sent to Source 2. When Source 2 voltage and frequency reach the preset “Restore” values, the time delay to open Source 1 timer (W) begins its timing cycle to ensure voltage and frequency stabilization before re-transfer. A manual pushbutton BYPASS is provided to bypass the “W” time delay if desired. After the (W) time delay, the MX controller initiates a transfer signal through the SCR-NO to operate the main transfer operator. The load is now transferred to the Open position. The time delay to Source 2 timer (DW) begins its timing cycle. After the (DW) time delay, the MX controller initiates a transfer signal through the SCR-E to operate the main transfer operator. The load is now transferred to Source 2 line. The transfer switch is mechanically locked. SN limit switch awaits the next operation to Source 1.

Restoration of Source 1 Power:

When Source 1 power reach the preset “Restore” values, the controller initiates re-transfer to Source 1 sequence. The delay to open Source 2Timer (T) begins its timing cycle to ensure voltage and frequency stabilization before retransfer. A manual pushbutton BYPASS is provided to bypass the “T” time delay if desired. After the (T) time delay, the MX controller initiates a transfer signal through the SCR-EO to operate the main transfer operator. The load is now transferred to the Open position. The time delay to Source 1 timer (DT) begins its timing cycle. After the (DT) time delay, the MX controller initiates a transfer signal through the SCR-N to operate the main transfer operator. The load is now transferred to Source 1 line. The transfer switch is mechanically locked. SE limit switch awaits the next operation to Source 2.

Immediately after re-transfer, the S2 Stop Delay Timer (Delay to Engine Stop “U”) begins its cycle to allow Source 2 Engine to run unloaded. A manual pushbutton BYPASS is provided to bypass the “U” time delay if desired. Upon completion of the (U) timing cycle, the controller sends an Engine stop signal.

Table 3

Timer Designations as they appear in the SET menu						
ATS Type	P	W	DW	T	DT	U
Open Transition	Time Delay S2 Start	Time Delay S2 Stable	ATS Open Time to S2	Time Delay S1 Stable	ATS Open Time to S1	S2 Stop Delay
Source 1 Fails	Transfer to Source 2 →		Source 1 Returns	← Transfer to Source 1		Engine Cooldown

Sequence of Operation *(cont'd)*

Closed Transition

GE Zenith Closed Transition Transfer Switches are designed to Transfer the Load between two available sources with out interrupting power to the Load (Make-Before-Break). Paralleling of the two sources occurs within a predefined window of synchronization and lasts less than 100 milliseconds. The initial Source is then disconnected.

Initiating a Closed Transition

When a Test is initiated, the controller initiates the Time Delay Source 2 Start (Engine Start Timer “P”) cycle. Upon completion of the (P) time delay, an Engine start Signal is sent to Source 2. When Source 2 voltage and frequency reach the preset “Restore” values, the time delay to open Source 1 timer (W) begins its timing cycle. After the (W) time delay, the ATS closes into Source 2 only after the controller ensures the proper phase relationship between the two Sources. After the ATS closes into Source 2, the SE limit switch becomes activated. The controller initiates a transfer signal through the SCR-NO which opens the ATS out of Source 1. The SNO limit switch activates. The ATS has now closed into Source 2 position without interrupting the load.

Re-Transfer with Closed Transition

Deactivating the Test Switch initiates the re-transfer. When Source 1 voltage and frequency reach the preset “Restore” values, the time delay to open Source 2 timer (T) begins its timing cycle. After the (T) time delay, the ATS closes into Source 1 only after the controller ensures the proper phase relationship between the two Sources. After the ATS closes into Source 1, the SN limit switch becomes activated. The controller initiates a transfer signal through the SCR-EO which opens the ATS out of Source 2. The SEO limit switch activates. The ATS has now closed back into Source 1 position without interrupting the load.

The ATS defaults to an open transition transfer when Source 1 fails. Closed transition transfer is not possible with only one source available. If the optional Transition Mode Selector (TMS) is available, one can select an Open Transition Transfer or a Closed Transition Transfer when both Sources are available.

If while in Closed Transition Mode, the ATS fails to open the source it is attempting to “transfer out of” within 100 milliseconds, an Alarm will sound and the source that the ATS just closed into will be opened leaving the ATS in its initial source while disabling all other transfer operations until the problem is corrected and the “Fail to Open Lockout Reset” has been pressed.

A signal will be provided (STE) to Shunt Trip the Generator Circuit Breaker if the Transfer Switch remains closed into both Sources for more than 325 milliseconds. The load will then be fed by the Source 1. The maximum time that the two Sources would be parallel, under these conditions, is less than 500 milliseconds. Before operating the Closed Transition Transfer Switch, the condition must be corrected and the Shunt Trip reset. Refer to procedure for servicing the Switch after Shunt Tripping occurs.

The unit is Factory set to accomplish transfer within 5 electrical degrees. Requires an Isochronous Governor with an operating frequency of 60+/- 0.2 Hz. Requires a Shunt Trip Breaker on the Generator set with a response time not exceeding 50 milliseconds.

Sequence of Operation *(cont'd)*

Bypass-Isolation Operation

An automatic transfer switch equipped with a bypass-isolation switch provides the ability to withdraw the ATS for testing and/or maintenance purposes without interrupting the served load.

Operation of the unit is quick and convenient requiring only one operator and less than one minute to complete. Instructions are mounted on the front of each isolation switch door along with a mimic panel providing indication of power source availability and ATS/bypass switch positions.

The bypass switch is normally open on both sources with the ATS feeding the system load. During operation, the bypass is closed paralleling the ATS contacts which then allows withdrawal of the ATS to the “TEST” or “ISOLATE” positions. Mechanical and electrical interlocks are included to prevent cross-servicing or bypassing to a dead source.

In the “TEST” position, the ATS is disconnected from the load (now fed through the bypass) but control power is present to allow complete operational testing through the control panel of the transfer switch.

In the “ISOLATE” position, the ATS is completely withdrawn and may be removed from the enclosure for maintenance if desired.

After the isolation operation, if the bypass is closed on Source 1 and if this source fails, an auxiliary contact on the bypass control will automatically start the engine-generator set. When the second source is available, the manual handle of the bypass may be operated to transfer the load to the available source. Interlocks prevent both this transfer, if the ATS is in the circuit and connected to the opposite source or reconnection of the ATS unless the positions match.

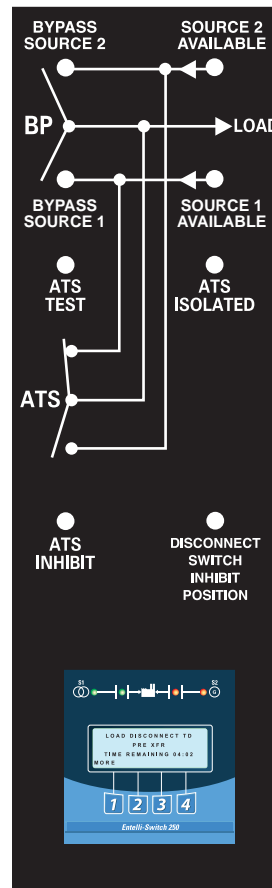

Figure 13

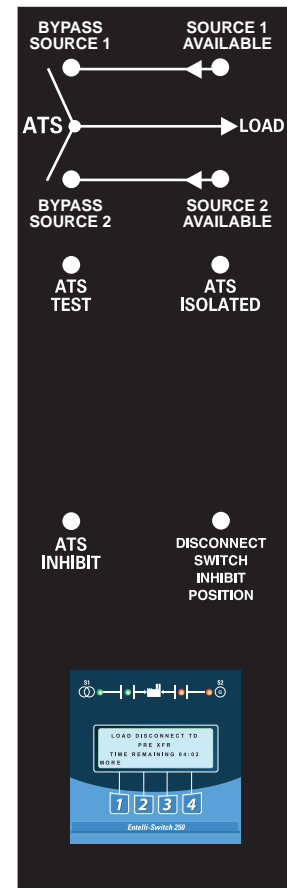

Figure 14

⚠ WARNING ⚠

While the bypass switch is out of the AUTO position/mode, the ATS is INHIBITED from automatic operation. Make certain the ATS is left in automatic after completion of any service.

Sequence of Operation *(cont'd)*

100-400 AMP

1) Automatic

- a) Manually operated Bypass Switch contacts (BN/BE) are open and ATS is supplying load.
- b) Disconnect Switch (DS) is in Auto.

2) To Bypass ATS

- a) Open bottom cabinet door and turn DS to Inhibit.
- b) Position manual bypass handle (MBH) to same power source as ATS.

3) To Test ATS

- a) Bypass per above instructions.
- b) Move ATS location handle (ALH) to Test location.
- c) Turn DS to Auto.
- d) Test Switch (TS) on bottom cabinet door will allow electrical operation of ATS.

4) To Isolate ATS

- a) Bypass per above instructions.
- b) Move ALH to Isolate location.

5) To Remove ATS

- a) Bypass and isolate per above instructions.
- b) Move ALH to Release location.
- c) Disconnect multipin plugs.
- d) Lift ATS out of drawer.

6) To Reconnect ATS

- a) Place ATS into drawer slots (front rollers first).
- b) Turn DS to Inhibit.
- c) Manually position ATS into same source as Bypass Switch.
- d) Reconnect multipin plugs and external connections to ATS.
- e) Push ATS inward to engage carriage.
- f) Move ALH to Test location (as indicated by light).
- g) Turn DS to Auto and use TS to electrically operate ATS.
- h) Turn DS to Inhibit.
- i) Move ALH to Auto location.
- j) Turn DS to Auto and open Bypass with MBH.
- k) ATS is now fully automatic.

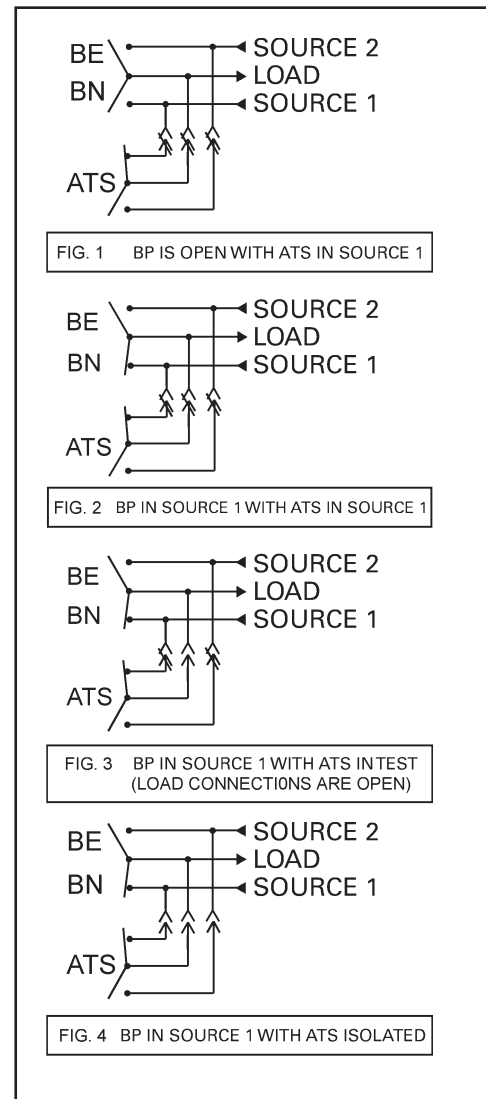

Notes:

1. DS in Inhibit will prevent ATS electrical operation.
2. Do not use excessive force on mechanical handles.
3. Figures depict Bypass Source 1. Sequence is the same for Bypass Source 2.
4. When ATS is in Test or Isolate, Bypass Switch is manual transfer switch to either available source (indicated on light panel).
5. To operate Bypass Switch when ATS is in Test or Isolate, position MBH to available power source.

Legend:

1. BP - Bypass switch (indicated by contacts BN/BE) is a three position switch.
2. ATS - Automatic Transfer Switch.

Figure 15

Sequence of Operation *(cont'd)*

600-1200 AMP

1) Automatic

- Manually operated Bypass Switch contacts (BN/BE) are open and ATS is supplying load.
- Disconnect Switch (DS) is in Auto.

2) To Bypass ATS

- Open bottom cabinet door and turn DS to Inhibit.
- Turn Bypass Selector Switch (BSS) to same power source as ATS
- Position manual bypass handle (MBH) upward.

3) To Test ATS

- Bypass per above instructions.
- Rotate crank mechanism counter-clockwise until ATS test light is illuminated.
- Turn DS to Auto.
- Test Switch (TS) on bottom cabinet door will allow electrical operation of ATS.

4) To Isolate ATS

- Bypass per above instructions.
- Rotate crank mechanism counter-clockwise until ATS Isolated light is illuminated.

5) To Remove ATS

- Bypass and isolate per above instructions.
- Disconnect multipin plugs and external connections to ATS.
- Rotate four power panel latches to vertical position, slide ATS forward and lock mechanism in place.
- ATS can now be removed from cabinet.

6) To Reconnect ATS

- Place ATS in slide mechanism.
- Unlock slide mechanism. Slide ATS over power panel latches and rotate latches to horizontal position.
- Turn DS to Inhibit.
- Manually position ATS into same source as Bypass Switch.
- Reconnect multipin plugs and external connections to ATS.
- Rotate crank mechanism clockwise until ATS Test light is illuminated.
- Turn DS to Auto and use TS to electrically operate ATS.
- Turn DS to Inhibit.
- Move ALH to Auto location.
- Turn DS to Auto and open Bypass with MBH.
- ATS is now fully automatic.

Notes:

- DS in Inhibit will prevent ATS electrical operation.
- Do not use excessive force on mechanical handles.
- Figures depict Bypass Source 1. Sequence is the same for Bypass Source 2.
- When ATS is in Test or Isolate, Bypass Switch is manual transfer switch to either available source (indicated on light panel).
- To operate Bypass Switch when ATS is in Test or Isolate:
 - Move MBH downward (to open Bypass Contacts BN/BE).
 - Turn BSS to opposite power source.
 - Move MBH upward to close into selected power source.

Legend:

- BP - Bypass switch (indicated by contacts BN/BE) is a three position switch.
- ATS - Automatic Transfer Switch.

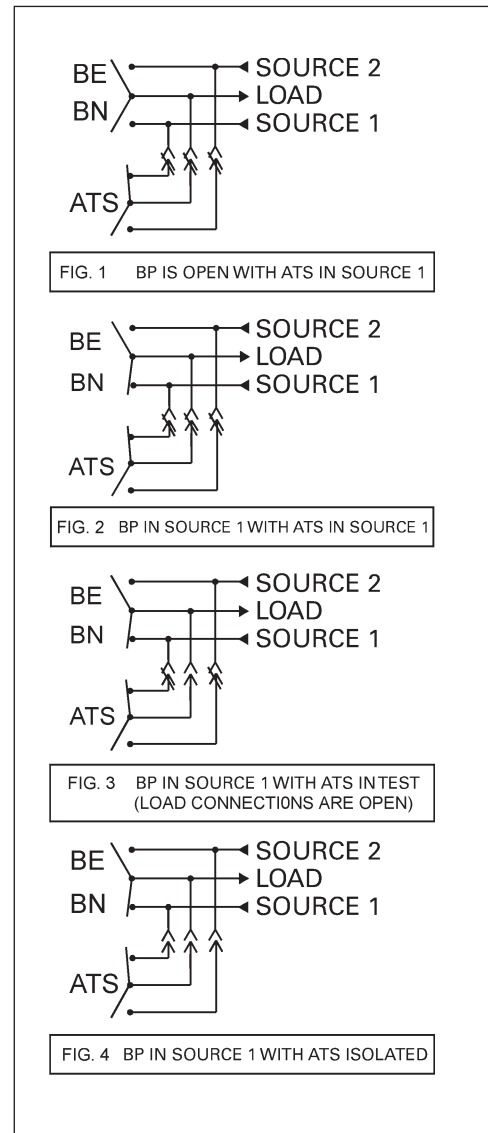

Figure 15

Sequence of Operation *(cont'd)*

1600-4000 AMP

1) Automatic

- a) Manually operated Bypass Switch contacts (BN/BE) are open and ATS is supplying load.
- b) Disconnect Switch (DS) is in Auto.

2) To Bypass ATS

- a) Open bottom cabinet door and turn DS to Inhibit.
- b) Turn Bypass Selector Switch (BSS) to same power source as ATS
- c) Position manual bypass handle (MBH) upward.

3) To Test ATS

- a) Bypass per above instructions.
- b) Rotate crank mechanism counter-clockwise until ATS test light is illuminated.
- c) Turn DS to Auto.
- d) Test Switch (TS) on bottom cabinet door will allow electrical operation of ATS.

4) To Isolate ATS

- a) Bypass per above instructions.
- b) Rotate crank mechanism counter-clockwise until ATS Isolated light is illuminated.

5) To Remove ATS

- a) Bypass and isolate per above instructions.
- b) Disconnect multipin plugs and external connections to ATS.
- c) Slide four corner latches of ATS to innermost position.
- d) ATS can now be removed from cabinet.

6) To Reconnect ATS

- a) Roll cart back into cabinet.
- b) Slide four corner latches of ATS to outermost position.
- c) Turn DS to Inhibit.
- d) Manually position ATS into same source as Bypass Switch.
- e) Reconnect multipin plugs and external connections to ATS.
- f) Rotate crank mechanism clockwise until ATS Test light is illuminated.
- g) Turn DS to Auto and use TS to electrically operate ATS.
- h) Turn DS to Inhibit.
- i) Rotate crank mechanism clockwise until ATS location pointer is aligned with Auto mark on location indicator. (ATS must be in same source as Bypass.)
- j) Turn DS to Auto and open Bypass with MBH.
- k) ATS is now fully automatic.

Notes:

1. DS in Inhibit will prevent ATS electrical operation.
2. DO NOT use excessive force on mechanical handles.
3. Figures depict Bypass Source 1. Sequence is the same for Bypass Source 2.
4. When ATS is in Test or Isolate, Bypass Switch is a manual transfer switch to either available source (indicated on light panel).
5. To operate Bypass Switch when ATS is in Test or Isolate:
 - a) Move MBH downward (to open Bypass Contacts BN/BE)
 - b) Turn BSS to opposite power source.
 - c) Move MBH upward to close into selected power source.

Legend:

1. BP - Bypass switch (indicated by contacts BN/BE) is a three position switch.
2. ATS - Automatic Transfer Switch.

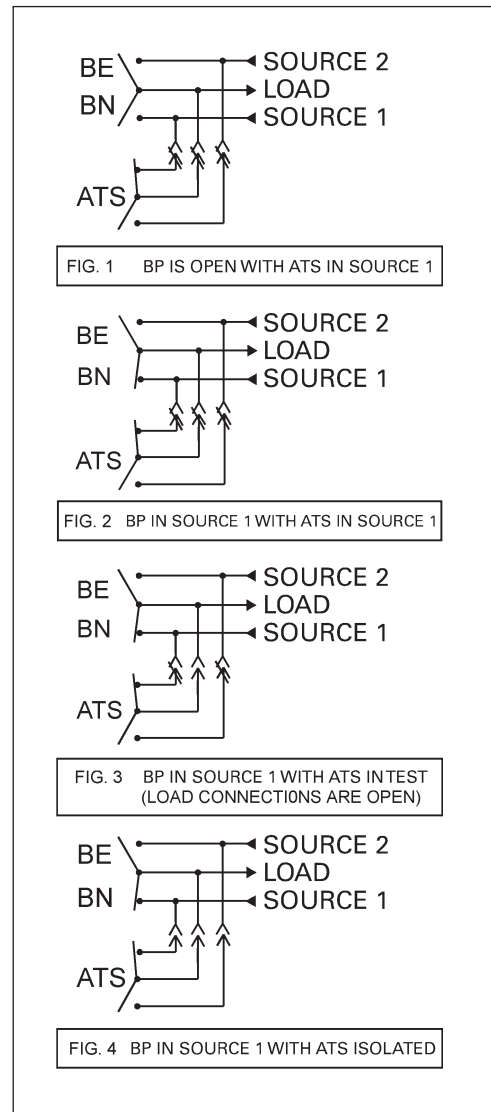

Figure 15

Sequence of Operation *(cont'd)*

1600-3000 AMP Horizontal Bypass

1) Automatic

- Manually operated Bypass Switch contacts (BN/BE) are open and ATS is supplying load.
- Disconnect Switch (DS) is in Auto.

2) To Bypass ATS

- Turn DS to Inhibit. *“Open bottom cabinet door” removed.*
- Open Bypass Isolation Access panel
- Turn Bypass Selector Switch (BSS) to same power source as ATS
- Position Manual Bypass Handle (MBH) upward

3) To Test ATS

- Bypass per above instructions.
- Rotate crank mechanism counter-clockwise until ATS test light is illuminated.
- Turn DS to Auto.
- Test Switch (TS) on microprocessor controller will allow electrical operation of ATS.

4) To Isolate ATS

- Bypass per above instructions.
- Rotate crank mechanism counter-clockwise until ATS Isolated light is illuminated.

5) To Remove ATS

- Bypass and isolate per above instructions.
- Open Automatic Transfer Switch access panel.
- Slide four corner latches of ATS to innermost position.
- ATS can now be removed from cabinet.

6) To Reconnect ATS

- Roll cart back into cabinet.
- Slide four corner latches of ATS to outermost position.
- Turn DS to Inhibit.
- Manually position ATS into same source as Bypass Switch.
- Close Automatic Transfer Switch access panel.
- Rotate crank mechanism clockwise until ATS Test light is illuminated.
- Turn DS to Auto and use TS to electrically operate ATS.
- Turn DS to Inhibit.
- Rotate crank mechanism clockwise until ATS location pointer is aligned with Auto mark on location indicator. (ATS must be in same source as Bypass.)
- Turn DS to Auto and open Bypass with MBH.
- ATS is now fully automatic.

Notes:

- DS in Inhibit will prevent ATS electrical operation.
- DO NOT use excessive force on mechanical handles.
- Figures depict Bypass Source 1. Sequence is the same for Bypass Source 2.
- When ATS is in Test or Isolate, Bypass Switch is a manual transfer switch to either available source (indicated on light panel).
- To operate Bypass Switch when ATS is in Test or Isolate:
 - Move MBH downward (to open Bypass Contacts BN/BE)
 - Turn BSS to opposite power source.
 - Move MBH upward to close into selected power source.

Legend:

- BP - Bypass switch (indicated by contacts BN/BE) is a three position switch.
- ATS - Automatic Transfer Switch.

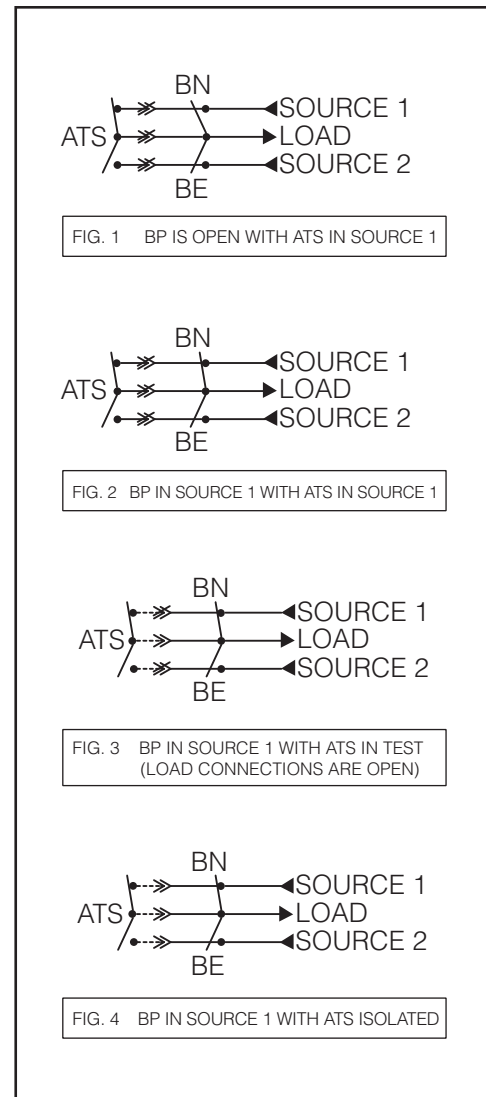

Figure 16

Controls Power Supply (CPS)

Closed Transition

Each Entelli-Switch 250 microprocessor based ATS controller requires a Controls Power Supply (CPS) to apply line voltage to the ATS operator via SCRs. Also required is power for the Entelli-Switch 250 printed circuit board and an application of sensing voltage proportional to line voltage. This is accomplished by

the Controls Power Supply (CPS). This method of switching operator voltage and applying power and sensing voltage to the printed circuit board isolates the MX250 from the line voltage, further protecting the controller from harmful line transients.

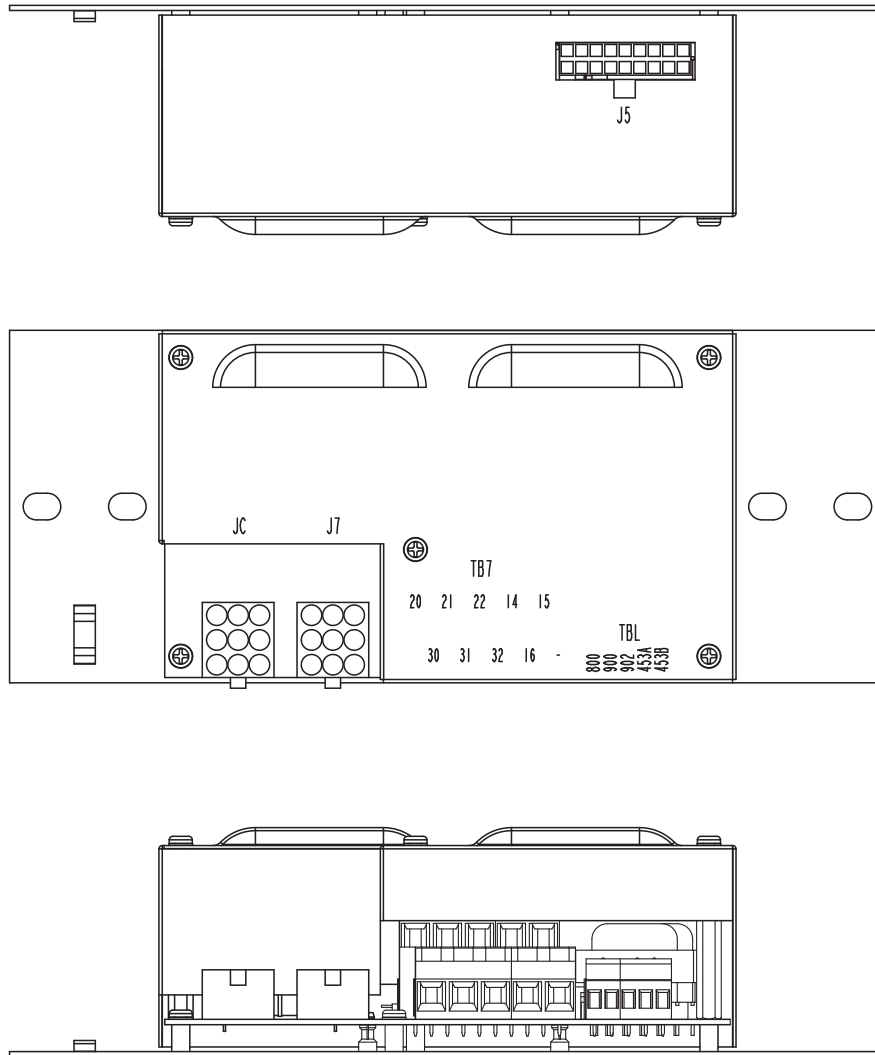

Figure 17

Primary Voltage at 50/60 Hz	CPS Assembly Part No.	CPS Board No.
120V	50P-1224	50P-1200
208-220V	50P-1225	50P-1201
230-240V	50P-1226	50P-1202
277V	50P-1227	50P-1203
380-400V	50P-1228	50P-1204
416-440V	50P-1229	50P-1205
460-480V	50P-1230	50P-1206
575-600V	50P-1231	50P-1207

Relay/Transformer (R/T Box) (cont'd)

Closed Transition CPS Schematic

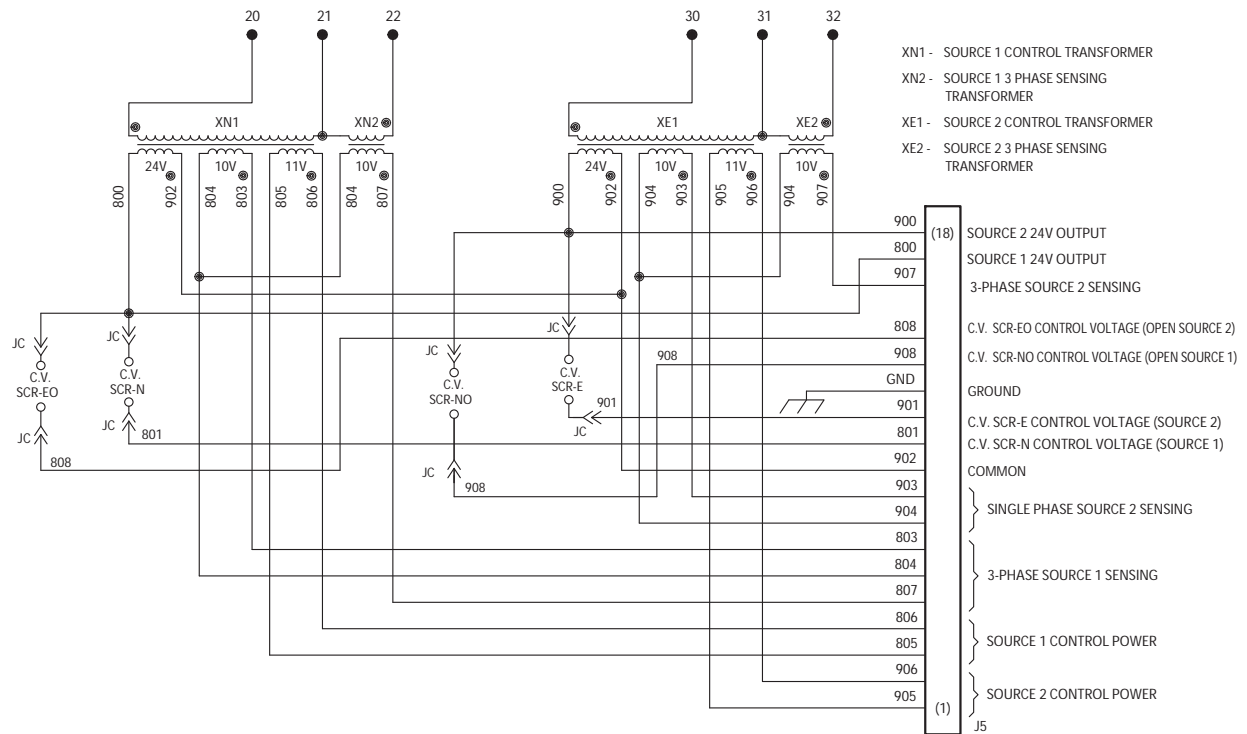

Figure 18

Troubleshooting and Diagnostics

⚠ DANGER ⚠

HAZARDOUS VOLTAGES CAN CAUSE SEVERE INJURY OR DEATH.

These charts may indicate problems that require authorized GE Zenith service personnel. Hazardous voltages may exist on termination plugs other than those that go into the Entelli-Switch 250.

General Troubleshooting

The following troubleshooting guide is used to recognize, and determine basic faults. When using this guide, it will ask several questions about the condition of the switch. This guide will then list an order of the possible faults. You will then look at the first suspected fault to determine if it is the problem. If it is not a fault, you go to the second suspected fault. If you go through all of the suspected faults, or the chart instructs you to, call a GE Zenith Representative for further assistance.

NOTE: When you use the troubleshooting charts, the Annunciation column refers to the LED's on the control panel.

Symptom	Annunciation	Possible Cause(s)	Corrective Action
Engine does not START	SOURCE 2 AVAILABLE LED off	Engine start wires not terminated properly	Check engine start connections
		Generator is in OFF position	Investigate why Engine Control Switch was turned off
Engine does not stop	LCD Display - "TD Engine Cool Down"	U timing cycle not complete	Check U timer setting
	SOURCE 1 POSITION, and SOURCE 1 and SOURCE 2 AVAILABLE LEDs on, but U timer has timed out	Engine start wires not terminated correctly	Check Engine Start Connections
		Generator in MANUAL	Place generator in AUTO
ATS will not transfer to SOURCE 2	SOURCE 2 AVAILABLE LED off	SOURCE 2 voltage or frequency not within acceptable parameters	Check: Engine Start Connections, Generator Breaker, Generator Output, and Engine Control Switch
	None	Power supply connector unplugged	Plug in connector
	LCD Display - "S1 ____ TD XFR S1>S2 Time Remaining ____"	W timing cycle not complete	Check W Timer setting
ATS will not transfer to SOURCE 1	LCD Display - "ATS Open Time Remaining ____"	DW timing cycle not complete	Check DW Timer setting
	SOURCE 1 AVAILABLE LED off	SOURCE 1 voltage or frequency not within acceptable parameters	Check utility and utility breakers
	None	Power supply connector unplugged	Plug in connector
	LCD Display - "Diagnostic Code 001"	Limit switch or RT box connector unplugged	Call Technical Services
	LCD Display - "S1 OK Time Remaining ____ Bypass"	T timing cycle not complete	Check T Timer setting
	LCD Display - "ATS Open Time Remaining ____"	TD timing cycle not complete	Check DT Timer setting

Table 4

Maintenance and Testing

⚠ CAUTION ⚠

Due to hazardous voltage and current, GE Zenith recommends that a GE Zenith Certified technician or a qualified electrician must perform the installation and maintenance of the switch.

⚠ WARNING ⚠

Both power sources must be disconnected before manual operation of the switch.

A preventive maintenance program will insure high reliability and long life for the transfer switch. The preventive maintenance program for the transfer switch should include the following items:

Inspection and Cleaning

The switch should be inspected for any accumulation of dust, dirt, or moisture, and should be cleaned by vacuuming or wiping with a dry cloth or soft brush. Do not use a blower since debris may become lodged in the electrical and mechanical components and cause damage.

Remove the transfer switch barriers and check the condition of the contacts. Any surface deposits must be removed with a clean cloth (do not use emery cloth or a file). If the contacts are pitted or worn excessively, they should be replaced. A general inspection of mechanical integrity should be made to include loose, broken or badly worn parts.

Servicing

All worn or inoperative parts must be replaced using GE Zenith recommended replacement parts. Please refer to the Replacement Parts manual for specific part information and ordering procedures. Please contact the GE Zenith Technical Services Department for the Replacement Parts manual.

The operating mechanism of the transfer switch is lubricated with Lubriplate 105. The lubricant applied at the factory provides adequate lubrication for the lifetime of the switch. Should debris contaminate the mechanism, clean and apply additional Lubriplate.

GE Zenith can provide complete preventative maintenance services. Please contact the GE Zenith Technical Services Department for additional information.

CDT battery replacement - lithium batteries may last up to 10 years, however it is recommended that battery replacement be included in a 3-5 year service cycle. The battery maintains the excerser memory only and does not otherwise affect the operation.

Testing

A manual operator handle is provided with the transfer switch for maintenance purposes only. Manual operation of the switch must be checked before it is operated electrically. **Both power sources must be disconnected before manual operation of the switch.** Insert the handle and operate the transfer switch between the Source 1 and Source 2 positions. The transfer switch should operate smoothly without binding. Return the switch to Source 1 position, remove the handle, and return it to the holder provided.

After completing the inspection, cleaning and servicing of the transfer switch, reinstall the switch cover, and close and lock the cabinet door. Reclose the circuit breakers feeding the utility and generator sources to the switch.

Initiate the electrical transfer test by activating the TS test switch. P timer will time out and the microcontroller will send an engine start signal. When the W time has elapsed, the switch will complete its transfer by closing into Source 2.

Deactivating the test switch will start retransfer to Source 1. The switch will complete its retransfer to Source 1 after the time delay of the T timer. The U engine overrun timer allows the engine generator to run unloaded for a preset cool down period.

NOTE: A periodic test of the transfer switch under load conditions is recommended to insure proper operation. (See National Electric Code articles 700 and 701).

⚠ WARNING ⚠

When performing a hi-pot or dielectric test on the power section, **DISCONNECT** the control panel plugs from the microprocessor to avoid potential damage.



Extensive Customer Service and Support

Supported by a worldwide network of factory-trained Authorized Service Centers, our Technical Service Representatives can provide you with field service, equipment parts and preventive maintenance.

Because emergency power systems are required to operate under the most adverse circumstances, site personnel may be called upon at any time to make decisions regarding the operation of the system, therefore training of these personnel is critical to the future of any installation.

GE offers a variety of training options including on-site classes for project personnel, factory instruction on your equipment prior to shipment and service schools covering transfer switches and switchgear systems.

Product Overview



When you purchase emergency power equipment, reliability and quality are a necessity. GE is committed to providing the highest level of quality demanded by the industry. Our complete product line will allow you to specify a total power management system while maintaining overall compatibility and the most comprehensive warranty in the industry.

Commitment to the Customer

All team members at GE are aware of the critical situations in which our products are called upon to perform. With that understanding comes an obligation beyond merely fulfilling an order or turning out a product. Serving that obligation is our mission at GE.

GE's team works with you from the first phone call through completed start-up. Then, working hand in hand with the consulting engineer, the contractor and the facility owner/operator, we'll ensure that the system fulfills both current and future needs.

"Commitment to our customer" has been GE's driving force for more than 100 years in the power control industry. This same sense of purpose and responsibility will continue as we address future power control challenges.



imagination at work

GE Digital Energy – Power Quality
830 W 40th Street, Chicago, IL 60609 USA
800 637 1738 www.gedigitalenergy.com/ats

Information subject to change without notice. Please verify all details with GE.
71R-5000B (11/08) © 2008 General Electric Company All Rights Reserved