



TSC 800

TRANSFER SWITCH CONTROLLER

**INSTALLATION, OPERATING &
SERVICE MANUAL**

Software Version 2.0

PM049 REV 7 04/12/16

TABLE OF CONTENTS

1. INTRODUCTION	1
1.1. PRODUCT REVISION HISTORY	1
1.2. GENERAL DESCRIPTION	2
2. INSTALLATION	5
2.1. GENERAL INFORMATION	5
2.2. NOTES TO INSTALLER	5
2.3. AC VOLTAGE SENSING INPUT	6
2.4. AC CONTROL POWER INPUT	6
2.5. OUTPUTS	7
2.6. SYSTEM PHASING-HIGH LEG DELTA SYSTEMS	7
2.7. EXTERNAL PANEL CONTROL WIRING	10
2.8. REMOTE START CONTACT FIELD WIRING	10
2.9. COMMUNICATION CABLE	11
2.10. DIELECTRIC TESTING	12
3. DESCRIPTION	12
3.1. LEXAN FACEPLATE	12
3.2. PRINTED CIRCUIT BOARD	14
3.2.1. POWER SUPPLY INPUT VOLTAGE SELECTION	14
3.2.2. TERMINAL BLOCKS	15
3.2.3. DIAGNOSTIC LEDs	15
3.2.4. COMMUNICATION PORT	16
3.2.5. CONTRAST ADJUSTMENT	16
4. REMOTE COMMUNICATION	16
5. TSC 800 DISPLAY MENUS	19
5.1. SYSTEM TIME MENU	19
5.2. ATS MODE MENU	20
5.3. TSC 800 PROGRAM MENU	23

5.4.	SYSTEM OPERATION MENU	23
5.5.	TIMER COUNTDOWN MENUS	25
5.6.	UTILITY SUPPLY MENU	26
5.7.	GENERATOR SUPPLY MENU	27
5.8.	STATS MENU	28
6.	OPERATING INSTRUCTIONS	28
6.1.	AUTOMATIC SEQUENCE OF OPERATION	28
6.1.1.	NORMAL SEQUENCE OF OPERATION (OPEN TRANSITION TRANSFER)	28
6.1.2.	NORMAL SEQUENCE OF OPERATION (CLOSED TRANSITION TRANSFER)	30
6.1.3.	TEST MODE SEQUENCE OF OPERATION	31
6.1.4.	ABNORMAL SEQUENCE OF OPERATION	32
6.2.	LCD DISPLAY OPERATION	32
6.4.1	OPERATOR INITIATED UTILITY POWER FAIL SIMULATION (LOAD TEST)	34
6.4.2	AUTOMATIC PLANT EXERCISE TEST	35
6.4.3	FOUR FUNCTION REMOTE TEST (FTS4 OPTION)	35
6.5	TRANSFER FAIL FAULT RESET	36
6.6	LAMP TEST	37
6.7	TIMER BYPASS	37
6.8	MANUAL UTILITY RE-TRANSFER	37
6.9	SERVICE ENTRANCE ATS MODE	37
6.10	PHASE BALANCE PROTECTION ALARM	38
7.	PROGRAMMING INSTRUCTIONS	39
7.1.	PASSWORDS	39
7.1.1.	READ ONLY MODE	39
7.1.2.	READ / WRITE MODE	39
7.1.3.	MASTER READ / WRITE MODE	39
7.2.	EXERCISE TIMER	40
7.2.1.	SYSTEM TIME ROLLOVER	41

7.2.2. AUTO TEST START DAY/WEEK NUMBER	41
7.2.3. AUTO TEST START HOUR	41
7.2.4. AUTO TEST START MINUTE	41
7.2.5. AUTO TEST STOP DAY/WEEK NUMBER	42
7.2.6. AUTO TEST STOP HOUR	42
7.2.7. AUTO TEST STOP MINUTE	42
7.2.8. AUTO TEST MODE	42
7.3. SYSTEM CONFIGURATION	43
7.3.1. FIRMWARE VERSION	43
7.3.2. ATS MODE MENU PASSWORD (PW)	43
7.3.3. UTILITY FAIL CALLOUT	43
7.3.4. LOAD ON GENERATOR CALLOUT	44
7.3.5. TRANSFER FAIL CALLOUT	44
7.3.6. AUTO TEST CALLOUT	44
7.3.7. MAN TEST CALLOUT	44
7.3.8. SWITCH NOT IN AUTO CALLOUT	45
7.3.9. NODE ADDRESS	45
7.3.10. SYSTEM VOLTAGE	45
7.3.11. VOLTAGE SENSING RATIO	45
7.3.12. SYSTEM FREQUENCY	45
7.3.13. SYSTEM PHASES	45
7.3.14. LOAD SENSING PHASES	46
7.3.15. PHASE BALANCE	46
7.4. VOLTAGE SENSING	47
7.4.1. UTILITY UNDER VOLTAGE SENSOR PICKUP	47
7.4.2. UTILITY UNDER VOLTAGE SENSOR DROPOUT	47
7.4.3. UTILITY UNDER VOLTAGE SENSOR TIME DELAY (DROPOUT)	47
7.4.4. UTILITY OVER VOLTAGE SENSOR PICKUP	47

7.4.5. UTILITY OVER VOLTAGE SENSOR DROPOUT	48
7.4.6. UTILITY OVER VOLTAGE SENSOR TIME DELAY (PICKUP)	48
7.4.7. UTILITY UNDER FREQUENCY SENSOR	48
7.4.8. UTILITY UNDER FREQUENCY SENSOR TIME DELAY (DROPOUT)	48
7.4.9. UTILITY OVER FREQUENCY SENSOR	48
7.4.10. UTILITY OVER FREQUENCY SENSOR TIME DELAY (PICKUP)	48
7.4.11. GENERATOR UNDER VOLTAGE SENSOR PICKUP	48
7.4.12. GENERATOR UNDER VOLTAGE SENSOR DROPOUT	49
7.4.13. GENERATOR UNDER VOLTAGE SENSOR TIME DELAY (DROPOUT)	49
7.4.14. GENERATOR OVER VOLTAGE SENSOR PICKUP	49
7.4.15. GENERATOR OVER VOLTAGE SENSOR DROPOUT	49
7.4.16. GENERATOR OVER VOLTAGE SENSOR TIME DELAY (PICKUP)	49
7.4.17. GENERATOR UNDER FREQUENCY SENSOR	50
7.4.18. GENERATOR UNDER FREQUENCY SENSOR TIME DELAY (DROPOUT)	50
7.4.19. GENERATOR OVER FREQUENCY SENSOR	50
7.4.20. GENERATOR OVER FREQUENCY SENSOR TIME DELAY (PICKUP)	50
7.5. GENERATOR CONTROL LOGIC	50
7.5.1. COMMIT TO TRANSFER LOGIC	50
7.5.2. GENERATOR START DELAY	51
7.5.3. GENERATOR WARMUP DELAY	51
7.5.4. GENERATOR COOLDOWN DELAY	51
7.5.5. PRE-TRANSFER DELAY (LDC)	51
7.5.6. POST-TRANSFER DELAY (LDC)	51
7.5.7. TRANSFER LOGIC	52
7.5.8. LOAD ON UTILITY PROGRAMMABLE OUTPUT	52
7.5.9. LOAD ON GENERATOR PROGRAMMABLE OUTPUT	53
7.5.10. MAXIMUM FIND NEUTRAL DELAY	53
7.5.11. NEUTRAL DELAY TIMER (NDT)	53

7.5.12.NEUTRAL DELAY BYPASS	54
7.5.13.MAXIMUM TRANSFER TIME	54
7.5.14.TRANSFER FAIL	54
7.5.15.MANUAL UTILITY TRANSFER RETURN	55
7.5.16.UTILITY RETURN DELAY	55
7.5.17.MAX SYNC TIME	56
7.5.18.MAX_POWER SWITCHING DEVICE OPEN TIME	56
7.5.19.PROGRAMMABLE OUTPUT	56
7.6. VOLTAGE SENSING CALIBRATION	57
7.6.1. GENERAL	58
7.6.2. UTILITY VOLTAGE CALIBRATION	59
7.6.3. GENERATOR VOLTAGE CALIBRATION	61
7.6.4. LOAD VOLTAGE CALIBRATION	63
8. TSC 800 PROGRAMMING DATA SHEETS	66
9. TSC 800 TYPICAL CONNECTION DIAGRAM	71
10. TSC 800 SPECIFICATIONS	72
11. TROUBLESHOOTING	73
12. REPLACEMENT PARTS	76
13. PRODUCT RETURN POLICY	77
14. NOTES	78

1. INTRODUCTION

1.1. PRODUCT REVISION HISTORY

The following information provides an historical summary of changes made to this product since the original release.

Software Version

2.0 04/12/14	New Features (Refer to Section 1.2)
1.7 02/04/01	Revised Transfer Fail Features and functionality
1.6 98/12/15	Added Remote Communication
1.5 N/A	Unreleased version
1.4 98/06/15	Updated Transfer Fail operation
1.3 98/01/19	Updated default under/over frequency setpoints, transfer fail programmability, minor logic revisions
1.2 97/10/10	Changed Transfer Switch fail timer to 30 seconds
1.1 97/01/30	Upgraded Frequency setting range
1.0 96/06/30	Original version

Operating & Service Manual Version

Rev 7 04/12/16	New Features (Refer to Section 1.2)
Rev 6 02/04/15	Changes for Version 1.7 TSC 800 Software
Rev 5 00/07/31	Added Four Position Test Switch Information
Rev 4 00/03/01	General revisions
Rev 3 99/02/12	Added Multi-tap information.
Rev 2 98/12/01	Added Remote Communication features per version 1.6 TSC 800 Software
Rev 1 98/01/21	General Revisions for upgraded TSC 800 software
Rev 0 97/06/04	Original release

Contact Thomson Technology, to obtain applicable instruction manuals. Soft copy of most current version is available at www.thomsontechnology.com.

1.2. GENERAL DESCRIPTION

The TSC 800 controller utilizes microprocessor-based design technology, which provides high accuracy for all voltage sensing and timing functions. The **TSC 800** is factory configured to control all the operational functions and display features of the automatic transfer switch. All features of the **TSC 800** are fully programmable from the front panel LCD display and are security password protected. The LCD display screen prompts are in plain English, providing a user-friendly operator interface with many display options available. The microprocessor design provides many standard features, which were previously only available as add-on optional features.

A summary of new and enhanced features provided in **SOFTWARE VERSION 2.0** Release is as follows:

- On Board Data Logging
 - Total Number of Transfers
 - Total Number of Transfers due to source failure
 - Number of Hours Controller is energized
 - Number of Hours Load is on Utility
 - Number of Hours Load is on Generator
- Timer Bypass Function
 - Faceplate Key Press Can Bypass Various Displayed Control Timer
 - Timer is Automatically Reset on Next Sequence
 - Operator Can Initiate Immediate Actions When Desired
- Phase Balance Sensing
 - Ensures Load is Fed from Balanced Source
 - Programmable Voltage Tolerance Settings
 - Phase Balance on Both Utility & Generator Sources
- Automatic or Manual Retransfer to Utility
 - User Programmable Retransfer Modes in Software
 - Manual Retransfer Requires Operator Key Press to Initiate Retransfer to Utility once Available
 - Manual Re-transfer is Automatically Bypassed on Generator Failure
- Auto Test Timer
 - Transfer Switch Allows User to Initiate an “Auto Test” Mode and after a Pre-programmed Time Delay, ATS Retransfers Back to Utility
 - 15 – 240 Min. User Programmable Timer in Software

- Auto Test Timer is Automatically Bypassed on GeneratorExtended Timer

Ranges

- Warmup Timer 0 – 3000 seconds (was 30 minutes)
- Cooldown Timer 0.0 – 50.0 minutes (was 30 minutes)
- Neutral Delay Timer 0 – 120 seconds (was 60 seconds)
- Utility Return Timer 0 – 50.0 minutes (was 30 minutes)
- Pre/Post Transfer Delay 0 – 300 seconds (was 120 seconds)
- 7, 14, 21, 28 Day Programmable Exercise Timer
 - Single Event Programmed Either Weekly, Every Second Week, Every Third Week or Once a Month
 - Allows Exercising On or Off Load (Programmable)
 - All Settings Stored in Non-Volatile Memory
- Programmable Commit to Transfer Logic
 - Transfer Logic can be Programmed to either Logic Scenario:Commit to Transfer to Generator Source only after Transfer to Generator Signal has been Initiated (Existing Logic)

Or

 - b) Commit to Transfer to Generator Source only after Engine Start Delay Timer Has Expired (New Logic). Can be used to prevent multiple Engine Starts. Auto resetting if the generator fails to start in 5 minutes.
- Neutral Delay Bypass
 - Neutral Delay Logic can be Programmed to either Logic Scenario:
 - a) When Disabled includes the programmed Neutral Delay Time once neutral positioning has been determined (Existing Logic).

Or

 - b) When Enabled only use as much of the programmed Neutral Delay Time as required in the neutral position until the load bus voltage drops below 20% of the nominal system voltage then completes the transfer to the alternate source (New logic). Can be used to reduce the total transfer time while still providing BEMF protection to the connected loads and/or power source. Also reduces retransfer times on loss of alternate source by reducing or cancelling the neutral delay time in a safe manner.
- Transfer Fail Logic & Alarming
 - More Descriptive Alarm Messaging: Utility Fail to Transfer, Generator Fail to Transfer, Utility Power Switching Failed, Generator Power Switching Device Failed

- Reduced time to detection of a Power Switching Device Failure
- Closed Transition ATS Models with Alarming in Software (Fail to Sync/Close, Fail to Trip)
- Standard Over Voltage & Frequency Sensing
 - Previously Available only as an Option
 - 3 Phase Utility & Generator Over Voltage and Over Frequency Sensing/Protection is Now Provided as Standard
 - Programmable Setpoints and Transient Time Delays
- Standard RS422 Remote Communications Port
 - Previously Available only as an Option
 - Communication Port Can be used with Thomson Technology CIM (for Modbus™ or THS Software) or Direct Connect previously only as an option
 - Utility source available (within voltage, frequency, & phase balance limits)
 - Generator source available (within voltage, frequency & phase balance limits)
 - ATS Not in Auto
 - 2nd Engine start output
 - Utility & Generator sources available
- Security Access for Key Pad Accessible ATS Mode Operation
 - User can Select Security Password prompts to permit access to Manually Initiated Test Modes via the Key Pads
 - Master Level Password Required to Change Access
- Auto Scrolling & Test Mode Display LCD Display will now Auto Scroll all Status Display Screens when no key presses have been initiated for more than 2 minutes
 - Activated Test Modes will now be displayed in Status Display Screens without need to re-enter the Test Mode Menu to view current selection
 - Sleep Mode - If No Key Presses, LCD/VFD Display Blanks for Longer Life when no key presses have been initiated for more than 5 minutes

™ Trademarks belong to their respective parties.

For detailed information on all new and enhanced features refer to specific sections within this manual.

2. INSTALLATION

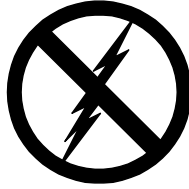

CAUTION

contents subject to damage by
STATIC ELECTRICITY

This equipment contains static-sensitive parts. Please observe the following anti-static precautions at all times when handling this equipment. Failure to observe these precautions may cause equipment failure and/or damage.

- Discharge body static charge before handling the equipment (maintain exposed body contact with a properly grounded surface while handling the equipment, a grounding wrist strap can/should also be utilized).
- Do not touch any components on the printed circuit board with your hands or any other conductive equipment.

Do not place the equipment on or near materials such as Styrofoam, plastic and vinyl. Place the equipment on properly grounded surfaces and only use an anti-static bag for transporting the equipment.

2.1. GENERAL INFORMATION

NOTE:

Installations should be done in accordance with all applicable electrical regulation codes as required.

The following installation guidelines are provided for general information only pertaining to typical site installations. For specific site installation information, consult Thomson Technology as required. **NOTE:** Factory installations of THOMSON TECHNOLOGY supplied transfer switches that have been tested and proven may deviate from these recommendations.

2.2. NOTES TO INSTALLER

If the transfer switch has programmable/multi-tap system voltage capability (refer to electrical schematic), confirm the transfer switch has been configured for the system voltage.

WARNING

Failure to confirm and match transfer switch voltage with the system voltage could cause serious equipment damage.

If the transfer switch requires reconfiguring, the TSC 800 controller will also require reprogramming.

CAUTION!!!

Qualified personnel must complete all installation and/or service work performed only. Failure to do so may cause personal injury or death.

2.3. AC VOLTAGE SENSING INPUT

The TSC 800 can accept direct AC voltage sensing inputs on the generator and utility supplies from 120-600VAC (nominal). **NOTE:** Direct input voltage sensing can only be used when the system utilizes a 3 phase, 4 wire distribution system which has the neutral conductor *solidly* grounded. For 3 phase, 3 wire systems (i.e. no neutral) or high voltage systems, potential transformers must be used (this is also the case where only 1 of the 2 supplies are 3 ph 3 w). Refer to FIGURES 1-4 for voltage sensing connections.

2.4. AC CONTROL POWER INPUT

The TSC 800 is factory supplied for either 115VAC or 230VAC (nominal) control power input voltage. Independent AC control power is required from both utility and generator supplies. AC control power is utilized for internal TSC 800 control circuits and external control device loads. The TSC 800 requires approximately 12VA AC power for internal control circuits. The maximum external load is limited by output contact ratings (i.e. 10A resistive, 120/250VAC). Total AC control power requirements for each supply must be determined by adding both internal and external load requirements.

2.5. OUTPUTS

The TSC 800 provides the following types of output circuits:

Engine Start Contact	Isolated Form C contact (10A, 250VAC Resistive)
Programmable Output Contact	Isolated Form C contact (10A, 250VAC Resistive)
Transfer to Utility Output	250VAC ¹ , 10A (Resistive) powered output contact
Transfer to Generator output	250VAC ¹ , 10A (Resistive) powered output contact
Pre/post-transfer to utility	250VAC ¹ , 3A (Resistive) powered output contact
Pre/post-transfer to generator	250VAC ¹ , 3A (Resistive) powered output contact
Load on utility	250VAC ¹ , 3A (Resistive) powered output contact
Load on generator	250VAC ¹ , 3A (Resistive) powered output contact

¹ **NOTE:** Output voltage is dependent upon AC control power input voltage (i.e. 120VAC or 230VAC nominal).

Interposing relays are required between the TSC 800 outputs and the end device if loads exceed the output current rating.

Transient suppression devices are required for all inductive devices sharing wiring or if physically located near the transfer switch controller.

For AC operated relays or solenoids, use a suitably rated metal oxide varistor (MOV) or capacitor/resistor suppressor. MOV selection should typically be equal to or slightly greater than 1.3 times the nominal RMS voltage being applied to the inductive device.

NOTE: Selecting an MOV of too low a value can/will result in a sustained short circuit and ultimately result in equipment failure.

2.6. SYSTEM PHASING-HIGH LEG DELTA SYSTEMS

When the transfer switch is connected to 3 phase 4 wire delta systems and no multi tap power supply transformers supplied with the ATS, the “High” leg, must be connected to Phase B of the Utility and/or Generator supply inputs to the ATS (Phase B, colored Orange per “NEC 384-3(e)” identified as the leg with highest potential with reference to ground). This will ensure the ATS control power that is internally connected between phase A and neutral is maintained at 120VAC. Refer to figure below for further details.

WARNING
*Failure to match correct system phasing
 will result in serious damage to the
 TSC 800 controller.*

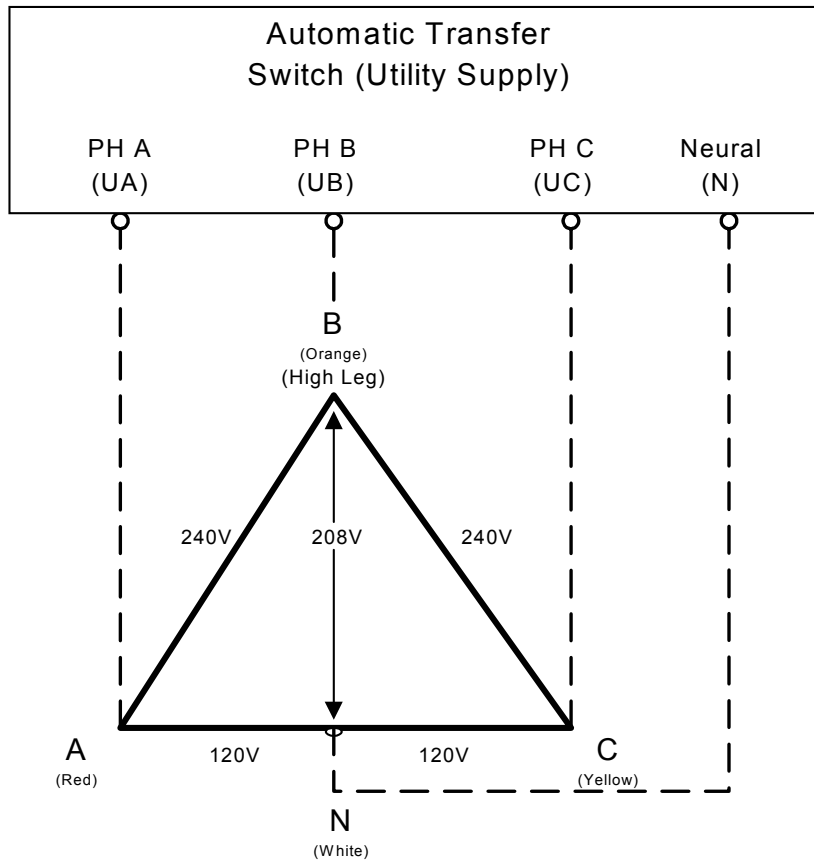

TSC 800

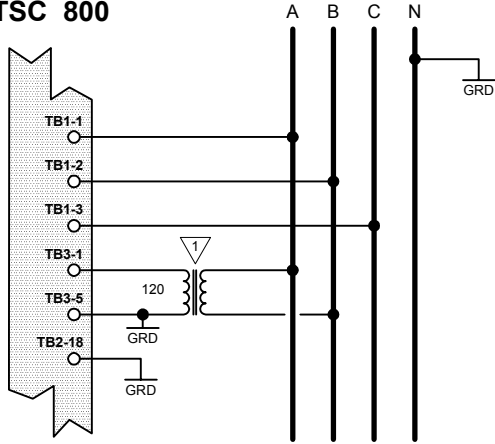

VOLTAGE INPUTS

600VAC L-L, 347VAC L-N
 480VAC L-L, 277VAC L-N
 380VAC L-L, 220VAC L-N
 208VAC L-L, 120VAC L-N

▽ PT REQUIRED FOR TRANSFER SWITCH MECHANISM POWER (MUST BE SIZED TO SUIT POWER REQUIREMENTS).

FIG:1
 3Ø, 4W 208/380/480/600VAC DIRECT SENSING

NOTE: UTILITY VOLTAGE SENSING AND CONTROL POWER SHOWN ONLY.

TSC 800

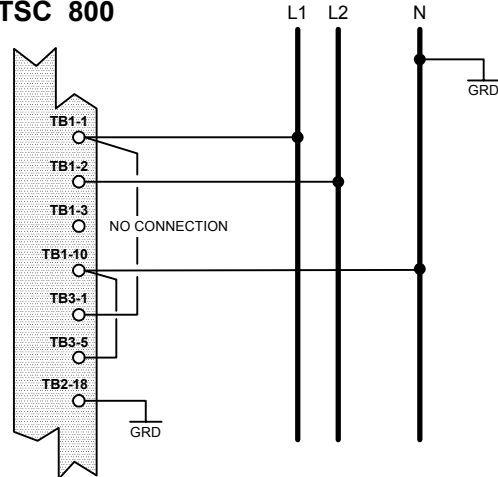

VOLTAGE INPUTS

240VAC L-L, 120VAC L-N

FIG:2
 1Ø, 3W 120/240VAC DIRECT SENSING

NOTE: UTILITY VOLTAGE SENSING SHOWN ONLY.

TSC 800

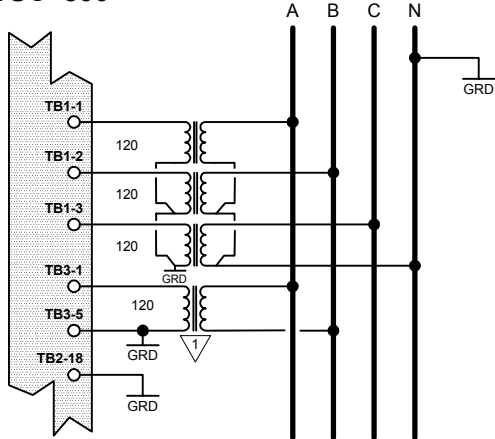

SECONDARY PT VOLTAGE

208VAC L-L, 120VAC L-N
 120VAC L-L, 69VAC L-N

▽ PT REQUIRED FOR TRANSFER SWITCH MECHANISM POWER (MUST BE SIZED TO SUIT POWER REQUIREMENTS).

FIG:3
 3Ø, 4W WYE PT's

NOTE: UTILITY VOLTAGE SENSING SHOWN ONLY.

TSC 800

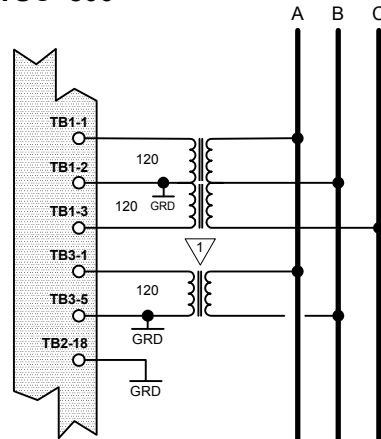

SECONDARY PT VOLTAGE

120VAC L-L [NO NEUTRAL]

NOTE: ØB IS GROUNDED

▽ PT REQUIRED FOR TRANSFER SWITCH MECHANISM POWER (MUST BE SIZED TO SUIT POWER REQUIREMENTS).

FIG:4
 3Ø, 3W DELTA PT's

NOTE: UTILITY VOLTAGE SENSING SHOWN ONLY.

2.7. EXTERNAL PANEL CONTROL WIRING

As a minimum, all control wiring shall conform to the local regulatory authority on electrical installations. Specific wire sizes listed below are for typical circuits of distances up to 500ft (150m)¹, are as follows:

Utility or Generator Voltage Sensing	#14 AWG (2.5mm ²)
Transfer output signals	#14 AWG (2.5mm ²)
Remote Start Contact for Engine Controls	#14 AWG (2.5mm ²)

NOTE: For long control wire runs or noisy electrical environments the control wires should be twisted & shielded with a suitable drain wire. The shielded cable drain wire must be grounded at one end only. The drain wire grounding location may vary as micro-processor controllers generally exist at both ends (engine generator set & transfer switch) and one may be more susceptible depending on the level of induced noise. The most susceptible controller will require the shield ground point as close as possible to the controller. Wire runs from 500ft to 1000ft should be twisted and shielded and increased to #12 AWG where total loop resistance is greater than 5 ohms.

¹ For distances exceeding 1000ft. (300m) consult Thomson Technology

2.8. REMOTE START CONTACT FIELD WIRING

Field wiring of a remote start contact from a transfer switch to a control panel should conform to the following guidelines to avoid possible controller malfunction and/or damage.

- 2.8.1. Remote start contact wires (2 #14 AWG (2.5mm²)) should be run in a separate conduit (ferromagnetic type) and in all cases separated from any AC wiring.
- 2.8.2. Avoid wiring near AC power cables to prevent pick-up of induced voltages.
- 2.8.3. An interposing relay may be required if field-wiring distance is excessively long (i.e. greater than 1000 feet (300m)) and/or if a remote contact has a resistance of greater than 5.0 ohms. In extremely noisy environments, the wire run lengths indicated may not provide reliable operation and can only be corrected by the use of an interposing relay. The interposing relay is generally installed at the engine controls and utilizes DC power. It is strongly suggested that the ground return wire of the interposing relay be used for the interface to the TSC 800 remote start contact, this will ensure integrity of the DC power supply to the engine generator set controls in the event of a shorted or grounded wire remote start interface wire.

2.8.4. The remote start contact provided is voltage free (i.e. dry contact). Exposing the remote start contact to voltage or current levels in excess of its rating will damage the transfer controller.

2.9. COMMUNICATION CABLE

Communication cable wiring from the controller's communication port must be suitably routed to protect it from sources of electrical interference. Guidelines for protection against possible electrical interference are as follows:

- Use high quality, 8 conductor shielded cable only with drain wire grounded at the controller end only.
- Route the communication cable at least 3 M (10') away from sources of electrical noise such as variable speed motor drives, high voltage power conductors, UPS systems, transformers, rectifiers etc.
- Use separate, dedicated conduit runs for all communication cables. Do not tightly bundle communication cables together in the conduit. Conduit should be ferromagnetic type near sources of possible electrical interference. The entire length of conduit should be grounded to building earth ground.
- When communication cables must cross over low or high voltage AC power conductors, the communication cables must cross at right angles and not in parallel with the conductors.

For additional information on protection against electrical interference, contact THOMSON TECHNOLOGY factory.

2.10. DIELECTRIC TESTING

Do not perform any high voltage dielectric testing on the transfer switch with the TSC 800 controller connected into the circuit, as serious damage will occur to the controller. All AC control fuses or control circuit isolation plugs connected to the TSC 800 must be removed/disconnected if high voltage dielectric testing is performed on the transfer switch.

3. DESCRIPTION

The TSC 800 controller consists of two parts; a Lexan faceplate, which is mounted externally on the transfer switch door, and a printed circuit board (PCB), which is mounted inside the transfer switch door.

3.1. LEXAN FACEPLATE

The Lexan faceplate is shown as in FIGURE 7. The Lexan pushbuttons are connected to the main PCB via plug-in ribbon cable. The main features of the Lexan faceplate are described as follows with reference to FIGURE 7.

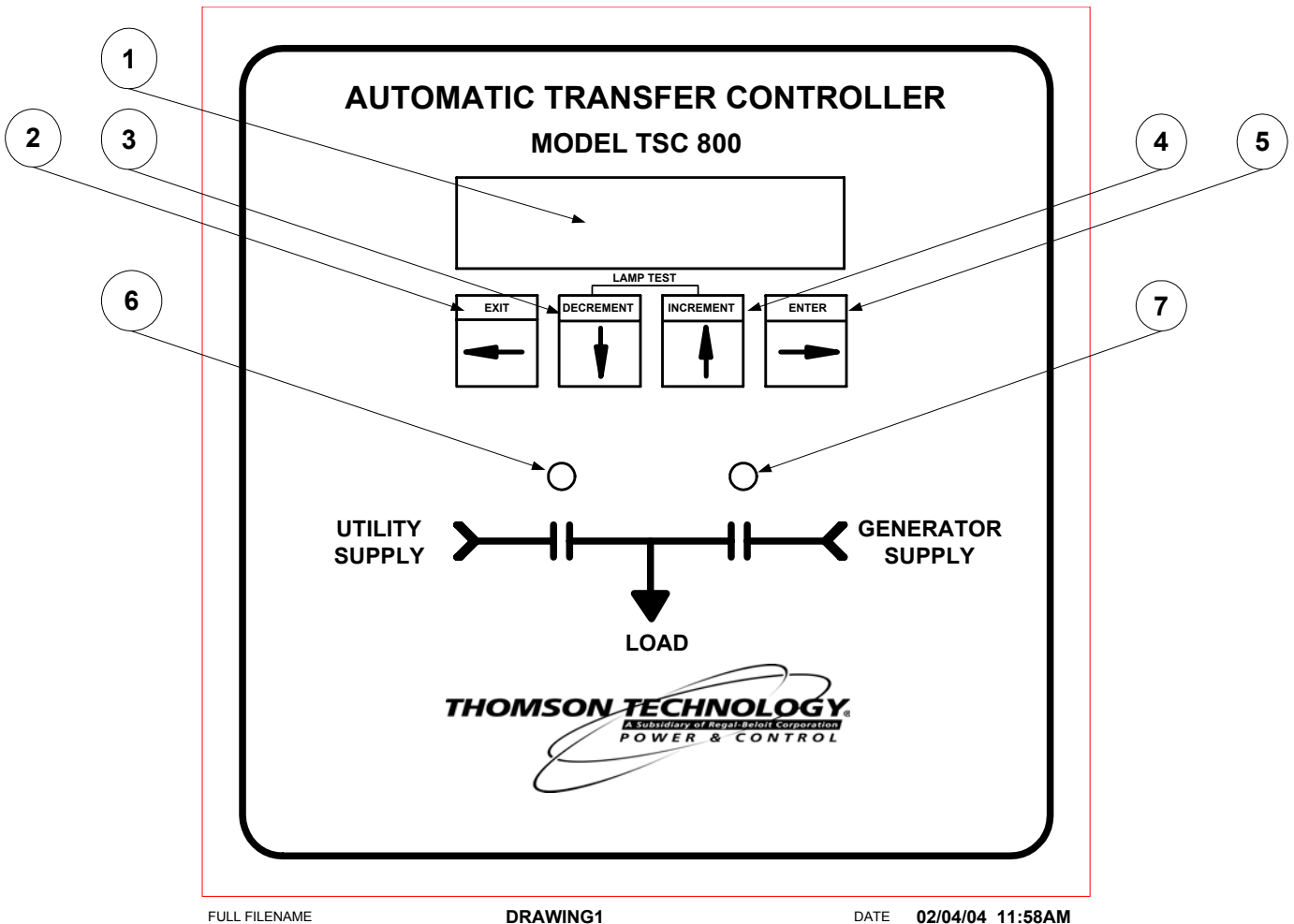

FIGURE# 7

- ① LCD viewing window. The LCD display is mounted on the main PCB which is visible from the lexan faceplate.
- ② EXIT pushbutton. The EXIT function is used to scroll backwards through the status menus or programming prompts to the previous item. The EXIT function is used to “exit” the programming menu by holding this button down for approximately 2 seconds while in the programming mode.
- ③ DECREMENT pushbutton. The DECREMENT function is used to change a programming value while in the programming mode. When this pushbutton is held down, the displayed value will be “decremented” to a lower value as desired. NOTE: The longer the pushbutton is held down, the faster the value will be decremented.
- ④ INCREMENT pushbutton. The INCREMENT function is used to change a programming value while in the programming mode. When this pushbutton is held down, the displayed value will be “incremented” to a higher value as desired. NOTE: The longer the pushbutton is held down, the faster the value will be incremented.
- ⑤ ENTER pushbutton. The ENTER function is used to scroll forwards through the status menus or programming prompts to the next item. The ENTER function is used to “enter” and accept new programming or operating mode changes after a new value has been selected (NOTE: Pressing the Exit button instead of the Enter button will reject the newly selected value and retain the original value). **NOTE:** In the programming mode, the longer the ENTER pushbutton is held down, the faster the next menu prompt will appear.
- ⑥ Load on Utility supply LED light viewing window
- ⑦ Load on Generator supply LED light viewing window

NOTE: A lamp test feature is provided to test all LED lights as well as the LCD display. To activate the lamp test feature, simultaneously push the INCREMENT and DECREMENT pushbuttons. All LEDs and LCD display pixels should illuminate for approximately 2 seconds then return to their original status. The Lamp Test feature is also used to clear active fault conditions and return the controller to normal operation.

NOTE: An active Timer Bypass feature is provided to allow a manual initiated bypass. To activate the feature, simultaneously push the DECREMENT and ENTER pushbuttons. The previously bypassed timer will operate normally during its next cycle. Refer to Timer Bypass section for related timers.

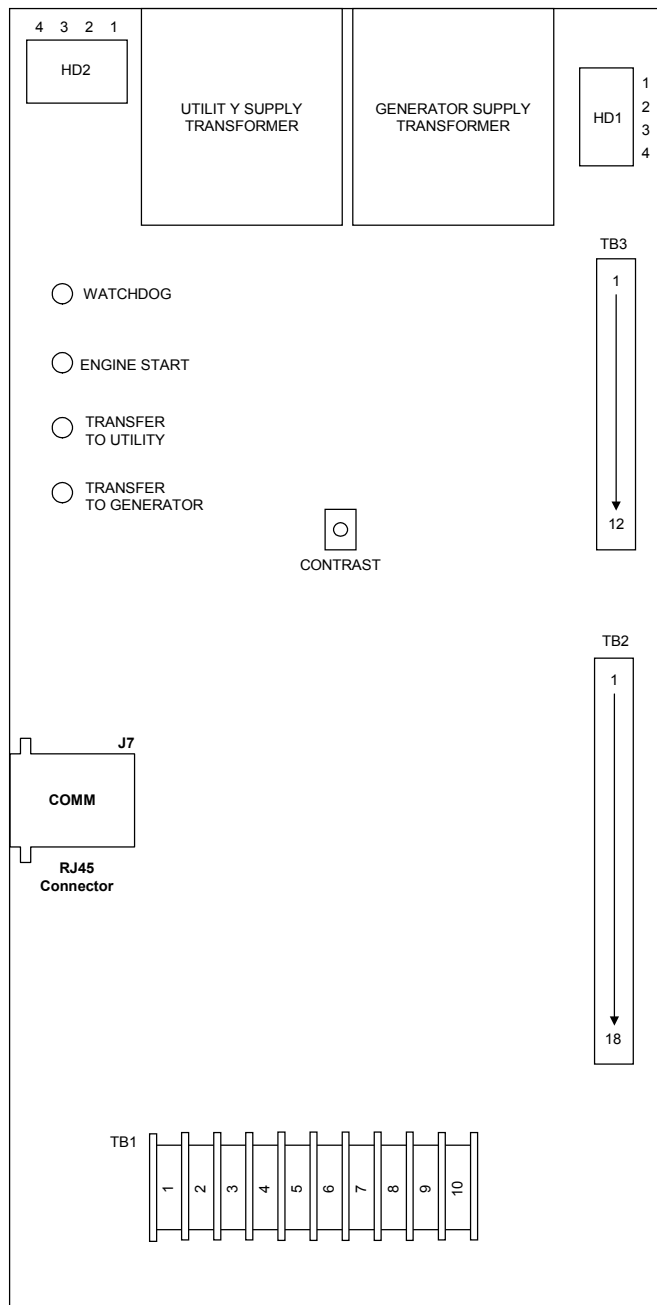

G:\ENGINEER\PRODUCTS\TSC800\852613b.VSD

FIGURE # 8

3.2. PRINTED CIRCUIT BOARD

The printed circuit board (PCB) is shown in FIGURE 8. The PCB contains the following user interface items:

3.2.1. POWER SUPPLY INPUT VOLTAGE SELECTION

The controller power supply input voltage level selection is made via two connector plugs, which are located on the PCB and are identified as HD1 and HD2. Voltage selection plug assemblies are unique for each power supply input level voltage

arrangement and must match the intended voltage level. Controller failure may result if incorrectly configured.

The TSC 800 is factory configured for a specific power supply voltage input as designated by voltage header plugs labeled as follows:

115V - designates a 115V power supply input voltage

230V - designates a 230V power supply input voltage

3.2.2. TERMINAL BLOCKS

Three terminal blocks are located on the PCB as follows:

TB1 High voltage sensing terminal block (120-600VAC)

WARNING

Voltage sensing circuits are capable of lethal voltages while energized. Standard safety procedures should be followed and be performed by qualified personnel only. Failure to do so may cause personnel injury and/or death.

TB2 Transfer control terminal block for output contacts and low voltage inputs

TB3 Transfer control terminal block for 115/230v input and output circuits

3.2.3. DIAGNOSTIC LEDs

The TSC 800 controller provides four diagnostic LED lights that are mounted on the rear of the printed circuit board as per FIGURE 8. Their functions are described as follows:

WATCHDOG

This LED flashes on and off at irregular intervals that indicate that the microprocessor is functioning normally.

ENGINE START

This LED is illuminated whenever the TSC 800 is initiating an Engine Start (except when there is no power to the TSC 800 controller).

TRANSFER TO UTILITY

This LED is illuminated whenever the TSC 800 is initiating a Transfer to Utility signal.

TRANSFER TO GEN

This LED is illuminated whenever the TSC 800 is initiating a Transfer to Generator signal.

NOTE: All LEDs will be illuminated whenever a lamp test function is performed.

3.2.4. COMMUNICATION PORT

A communication port is provided to interconnect to a remote communication system for remote monitoring and control of the transfer switch. Refer to Section 4 for additional information.

3.2.5. CONTRAST ADJUSTMENT

A contrast adjustment potentiometer is located on the PCB and is factory set for ambient temperatures of 15° to 30° Celsius. For different ambient temperatures, consult the factory for adjustment procedures.

4. REMOTE COMMUNICATION

The TSC 800 transfer switch controller is available with a remote communication feature. The remote communication feature allows a TSC 800 controller to be monitored and controlled from a remote location via serial communication link to a personal computer (PC). PC's may be connected locally via serial communication cable to the TSC 800 or remotely via modem and telephone systems. Remote communication can be via customer-supplied equipment or with an external communication interface module (CIM) as manufactured by Thomson Technology.

NOTE:

The CIM module may be located in the engine control panel provided the maximum distance between the CIM and TSC 800 controller is not exceeded as per the following information. Refer to the installation section of this manual for further information.

The CIM module utilizes an internal modem and contains Modbus™ protocol to interface with different remote monitoring software programs. Refer to separate literature for detailed information on the CIM module.

The TSC 800 communication port utilizes a RS422 data transmission signal that is directly interconnected to the CIM module via an 8 conductor, shielded cable with plug-in RJ45 connectors. Refer to FIGURES 9 & 10 for detailed information on direct connected or remote connected PC applications with CIM module.

™ Trademarks belong to their respective parties.

NOTE: Both phone and serial communications ports can be connected at the same time. Doing so will result in no communication and/or possible CIM failure.

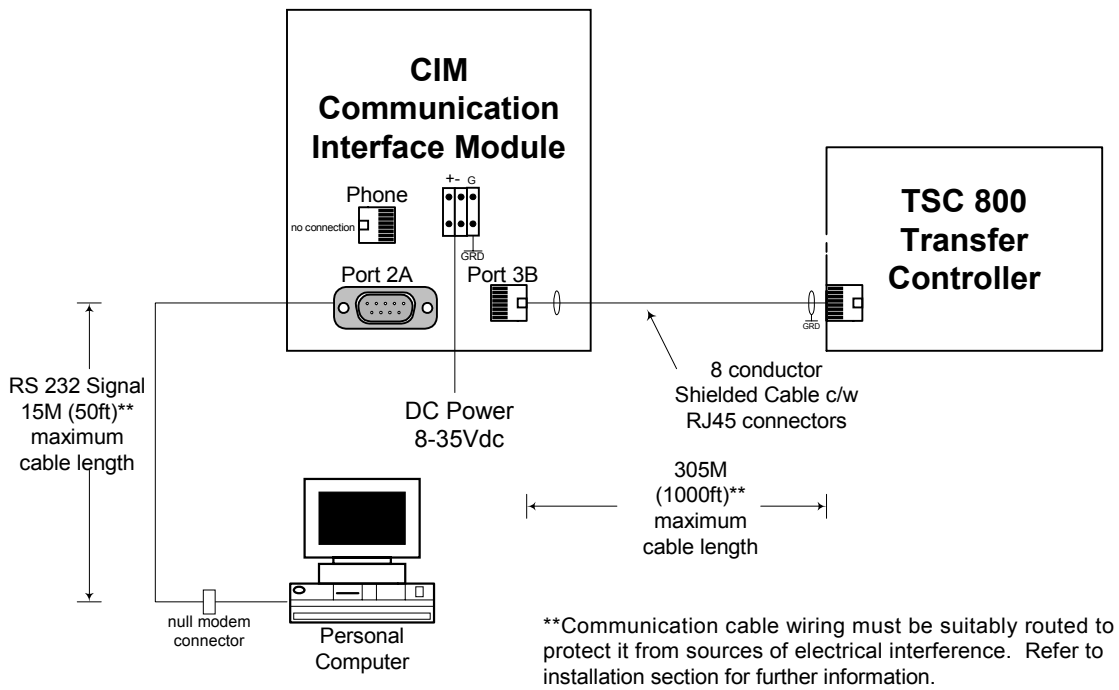

G:\ENGINEER\PRODUCTS\TSC800\852621.VSD

FIGURE #9 TSC 800 WITH CIM MODULE & DIRECT CONNECTED PC (RS232)

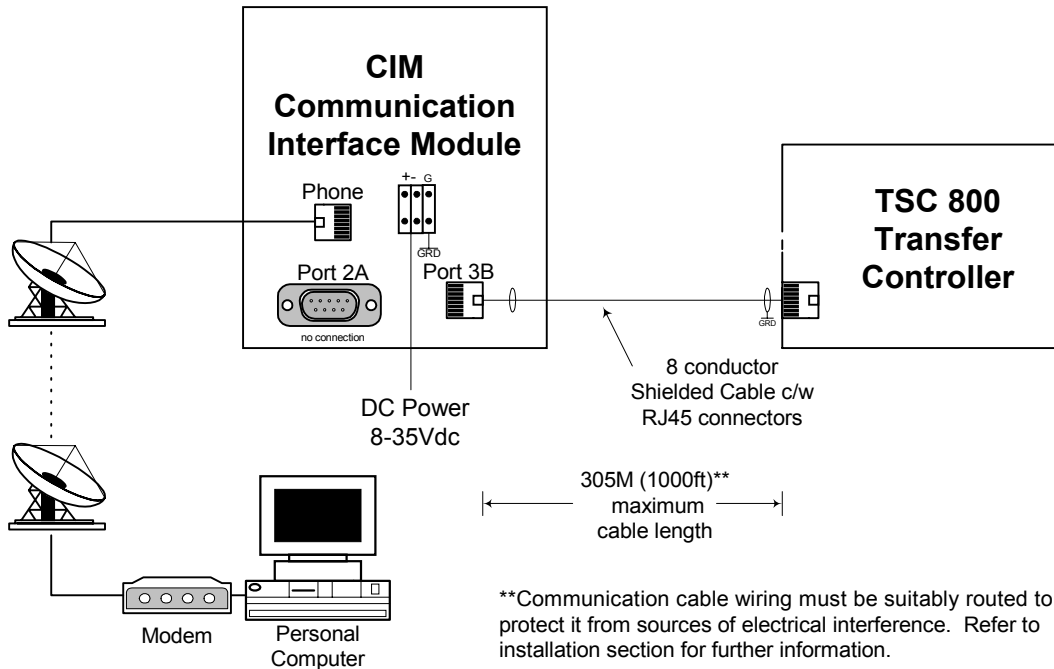

G:\ENGINEER\PRODUCTS\TSC800\852622.VSD

FIGURE #10 TSC 800 WITH CIM MODULE & REMOTE CONNECTED PC

The TSC 800 RS422 communication port allows multiple TSC 800 controllers to be directly interconnected together to form a single network system. Up to 10 TSC 800 controllers may be interconnected to a single CIM module.

NOTE:

TSC 800 controllers and MEC 20 engine-generator controllers may be interconnected together via the same communication network provided the maximum number of controllers and interconnection distances are not exceeded. For additional information, refer to associated product instruction manuals.

Each TSC 800 controller is programmed with a unique communication node address number for the remote communication system to reference. The network system may be connected to a local PC or to a remote PC via telephone system and CIM module. Refer to FIGURE #11 for a typical TSC 800 network system with CIM module.

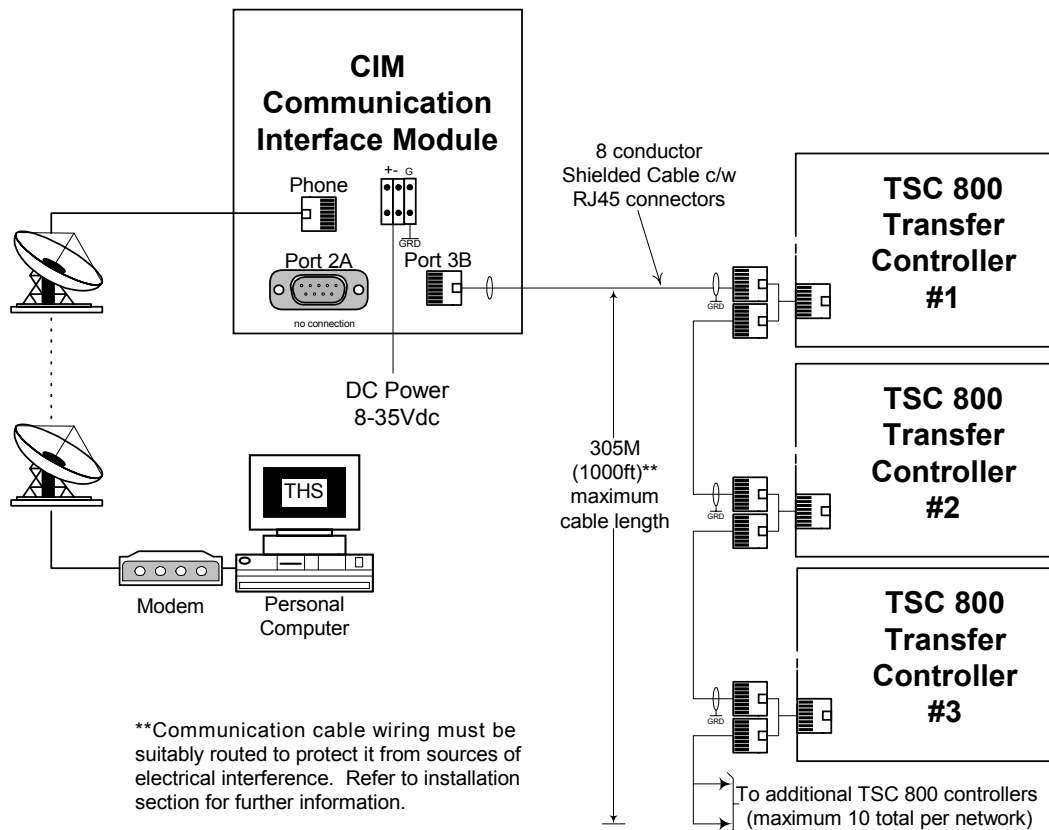

G:\ENGINEER\PRODUCTS\TSC800\852623.VSD

FIGURE #11 NETWORKED TSC 800 INTERCONNECTION DIAGRAM

5. TSC 800 DISPLAY MENUS

The TSC 800 contains a Liquid Crystal Display (LCD) that is visible on the front faceplate. The LCD has pre-programmed display menus which are automatically displayed in an auto-Scrolling mode or they may be selected manually by pressing the *ENTER* or *EXIT* pushbuttons in succession until the desired menu is displayed. The display menu types and order in which they are programmed are as follows:

NOTE:

The following display menus are provided in TSC 800 Software version 2.0 (or higher).

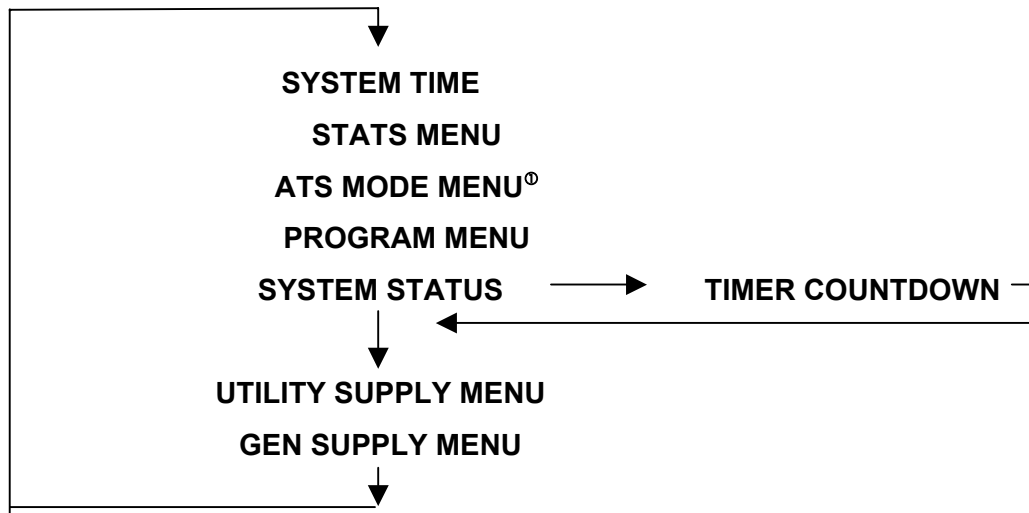

^⓪**NOTE:** ATS MODE MENU access may be inhibited. Refer to programming instruction for further details.

5.1. SYSTEM TIME MENU

The system time menu is used to show current system time and week number. The TSC 800 controller uses its internal time clock to reference when an automatic exercising operation (if pre-programmed) is to occur. To change the system time, refer to the “time clock adjustment” section of this manual.

NOTE:

The following system Time menu is provided in TSC 800 Software version 2.0 (or higher).

LCD DISPLAY



- ① Displays the day of the week (e.g. Monday)
- ② Displays the week number (e.g. 1-4)
- ③ Displays the current time in hours (24-hour clock): hour: min: seconds

5.2. ATS MODE MENU

The ATS Mode Menu provides manually selectable operating modes which includes On/Offload testing features (comparable features also available via external inputs utilizing an optional FTS4 selector switch). The Internal and External ATS Mode inputs operate in a parallel fashion; the Mode of Operation will be determined by the highest priority selected by either format. The priority levels are as follows (highest to lowest priority):

- 1) Off (Controller out of Service, no control logic applied)
- 2) Onload Test
- 3) Offload Test
- 4) Auto

A utility power failure will over ride all but “Off”. In the event of a generator failure and the utility supply is available and considered normal, the ATS will return to the utility supply except when “Off” selected.

NOTE:

The following test menu is provided in TSC 800 Software version 2.0 (or higher).

The ATS Mode sub-menus are organized as follows:

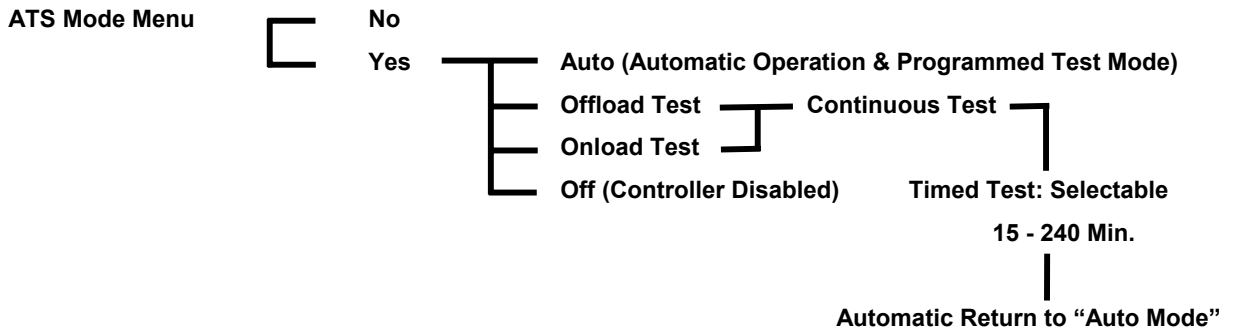

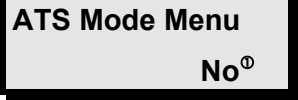
LCD DISPLAY

 A screenshot of the ATS Mode Menu on an LCD display. The text 'ATS Mode Menu' is at the top, and 'No^①' is displayed below it.

① Displays two messages that may be toggled between *YES* or *NO* by pressing the *INCREMENT* or *DECREMENT* pushbuttons. Their functions are described as follows:

- No** Status message only, a change is required to gain access.
- Yes** The required variable to be entered to gain access and proceed. If the password protect feature is enabled a prompt will appear requiring a level 2 or greater security code be entered to allow a read-write access. Entering a level 1 password will only permit a read only access.

The following ATS Mode Menu options are provided:

Auto This is the Default Selection and is required to enable all automatic features of the controller. In this mode the TSC 800 Controller will automatically transfer the load to the appropriate source based on availability (the Utility supply is considered the preferred source). The TSC 800 will provide automatic timed testing if enabled in programming. Manual testing is disabled when the Auto ATS mode is selected (NOTE: the external mode inputs input will over ride ATS Mode Menu selected Auto mode).

Offload Test When the Offload Test prompt is selected and entered, the generator will immediately start and operate offload and will not permit a load transfer. The test menu will display Continuous Test, to select a timed test use the *INCREMENT* or *DECREMENT* pushbutton to scroll and select a test duration time, press enter to accept the time (selectable in 15 minutes increments from 15 – 240 min.). The generator will remain running until a different mode is selected and entered or the timed test duration expires (selecting Auto will immediately terminate the test). On expiry of the timed test the operating mode automatically reverts to Auto.

NOTE: If the Utility supply fails during this test mode, the load will automatically transfer to the generator if within acceptable limits.

Onload Test When the Onload Test prompt is selected and entered, the generator will immediately start and transfer on load. The test menu will display Continuous Test, to select a timed test use the *INCREMENT* or *DECREMENT* pushbutton to scroll and select a test duration time, press enter to accept the time (selectable in 15 minutes increments from 15 – 240 min.). The generator will remain running until a different mode is selected and entered or the timed test duration expires (selecting Auto will terminate the test after the Utility Return Timer has expired). On expiry of the timed test the operating mode automatically reverts to Auto.

NOTE: Should the Generator fail during the onload test and the Utility supply is available and within acceptable limits the load will be transferred on expiry of the generator under voltage delays.

Off The TSC 800 Controller is considered out of Service. The transfer mechanism logic outputs are dropped out and disabled. The transfer switch will remain in its last position and the remote start removed if previously enabled. Manual and auto test features are disabled. This selection takes precedence over all other modes.

NOTE: When this mode is selected the local generator controls should also be placed in *OFF*. Failing to do can result in cyclical engine starting. On loss of Utility supply in this state (loss of control power to the TSC 800) the engine start contact will drop out after approximately 4 minutes resulting in generator starting and stopping (the cycle will repeat approximately every 4 minutes after the control power is removed).

NOTE: On return to normal service the Engine Start output is inhibited (held up) for approximately 8 – 10 seconds. Requesting another mode of operation during this time, which requires the engine start contact to close, will be ignored.

5.3. TSC 800 PROGRAM MENU

The programming menu is used to access the TSC 800's programmable functions such as time delays, voltage/frequency setpoints, calibration and time clock adjustments.

Access to the programming sub-menus can only be obtained with a security password number. The sub menus are organized as follows:



LCD DISPLAY

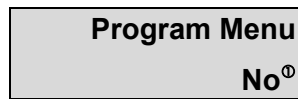

^⓪ Displays two messages that may be toggled between YES or NO by pressing the *INCREMENT* or *DECREMENT* pushbuttons. Their functions are described as follows:

NO Status message only, a change is required to gain access.

YES The required variable to be entered to gain access and proceed. The password protection prompt will appear requiring a level 2 or greater security code be entered to provide a read-write access. Entering a level 1 password will permit a read only access.

5.4. SYSTEM OPERATION MENU

The system operation menu provides the operator with information as to current status of both the utility and generator supplies.

NOTE:

The system operation menu screen may be momentarily replaced with a time delay countdown screen when a transfer sequence is initiated. The display will automatically return to the previous menu following expiry of the timing sequence.

The system operation sub-menus are organized as follows:

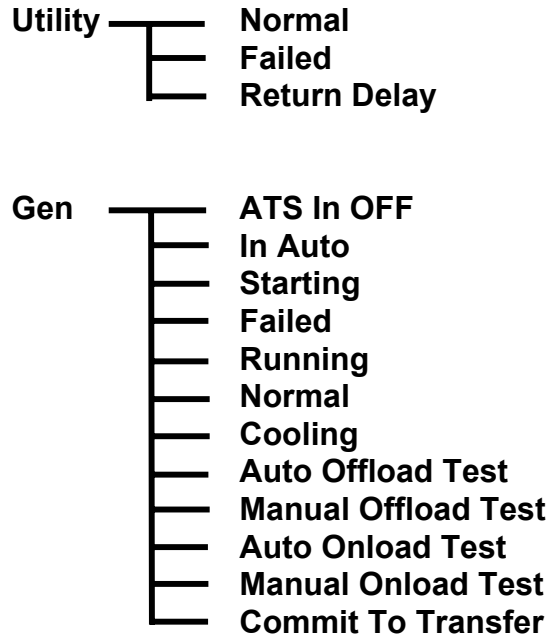

LCD DISPLAY

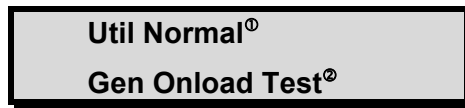

[ⓐ] Displays utility supply status conditions. There are three status conditions:

- Normal** Load is on the utility supply and the utility’s voltage and frequency is normal.
- Failed** Utility supply voltage and/or frequency are outside the nominal programmed limits (e.g. failed condition).
- Return Delay** Load is on the generator supply and the utility supply is ready to transfer. This is a temporary condition due to either a test mode being selected or during a utility return time delay.

[ⓑ] Displays generator supply status conditions. There are twelve status conditions as follows:

- ATS In Off** The ATS Mode has been set to OFF via the Internal or External switch input. The Controller will display the message “Controller Out of Service”.
- In Auto** The ATS Mode via the Internal ATS Mode Menu has been set to Auto.
- Starting** Engine start signal has been initiated, and the TSC 800 sensors are waiting for generator voltage to build up.

Failed	Generator is signaled to operate; however its voltage and/or frequency is outside the nominal programmed limits (e.g. failed condition).
Running	The generator is running (within programmed limits) but not requested to transfer on load by the controller.
Normal	The generator is running due to a failed utility supply.
Cooling	The generator is running (within programmed limits) during the programmed cooldown delay.
Auto Offload Test	The generator is running off load due to a programmed exercise timer mode.
Manual Offload Test	The generator is running off load due to manually initiated off load test mode via the front-panel pushbuttons or external inputs.
Auto Onload Test	The generator is running on load due to a programmed exercise timer mode.
Manual Onload Test	The generator is running on load due to manually initiated on load test mode via the front-panel pushbuttons or external inputs.
Commit To Transfer	When enabled, the generator will be committed to transferring on load if the loss of utility is detected and the engine start issued. The generator will remain on load for the duration of the power failure and the transfer return time. If the generator fails to start within 5 minutes the commit to transfer request is cancelled.

5.5. TIMER COUNTDOWN MENUS

Timer countdown menus are automatically displayed when a specific time delay function occurs during a transfer sequence. When a time delay begins, the LCD display will indicate the time delay function name (e.g. Gen Start Delay) and the current time remaining in the countdown sequence. When the timing function is complete, the LCD display will automatically change to either the next timing sequence countdown display or return to auto scrolling the system status screens.

LCD DISPLAY

Gen Start Delay^① 45 Sec^②

- ① Displays specific time delay function currently in operation
- ② Displays current time in seconds that are left in the specific timing sequence.

NOTE:

During a timer countdown sequence, scrolling to a different display screen is possible by pressing either the *ENTER* or *EXIT* pushbuttons.

The following timer countdown screens are provided and displayed in seconds of time remaining:

Gen Start Delay	Gen Warm up Delay
Gen Cooling Delay	Utility Return Delay
PreTransfer Delay	PostTransfer Delay
Finding Neutral	Neutral Delay
PSD Max Open Time	Transferring
Syncing (Close Transition Feature Only)	

5.6. UTILITY SUPPLY MENU

The utility supply menu allows the operator to view the utility supply voltage and frequency values.

LCD DISPLAY

Util 60.0Hz^① 600^② 600^③ 600^④

- ① Displays utility supply frequency in hertz (Hz). The frequency is displayed with a resolution of 1/10 of a hertz.
- ② Displays utility supply voltage as follows:
 - 3-phase system: LINE TO LINE VOLTAGE--Phases A to B
 - 1-phase system: LINE TO LINE VOLTAGE--Phases L1 to L2
- ③ Displays utility supply voltage as follows:
 - 3-phase system: LINE TO LINE VOLTAGE--Phases B to C
 - 1-phase system: LINE TO NEUTRAL VOLTAGE--Phases L1 to N

- ④ Displays utility supply voltage as follows:
 - 3-phase system: LINE TO LINE VOLTAGE--Phases C to A
 - 1-phase system: LINE TO NEUTRAL VOLTAGE--Phases L2 to N

5.7. GENERATOR SUPPLY MENU

The generator supply menu allows the operator to view the generator supply voltage and frequency values.

LCD DISPLAY

Gen	60.0Hz ^①
600 ^②	600 ^③ 600 ^④

- ① Displays generator supply frequency in hertz (Hz). The frequency is displayed with a resolution of 1/10 of a hertz.
- ② Displays generator supply voltage as follows:
 - 3-phase system: LINE TO LINE VOLTAGE--Phases A to B
 - 1-phase system: LINE TO LINE VOLTAGE--Phases L1 to L2
- ③ Displays generator supply voltage as follows:
 - 3-phase system: LINE TO LINE VOLTAGE--Phases B to C
 - 1-phase system: LINE TO NEUTRAL VOLTAGE--Phases L1 to N
- ④ Displays generator supply voltage as follows:
 - 3-phase system: LINE TO LINE VOLTAGE--Phases C to A
 - 1-phase system: LINE TO NEUTRAL VOLTAGE--Phases L2 to N

NOTE: The load bus voltages are viewable only in the Programming Menu. When selected as 3-phase load sensing it will be displayed as listed above for 3-phase systems. When selected as 1-phase, only the L1 to L2 voltage will be displayed as a line-to-line value. 3-phase load sensing can only be selected if all 3 phases of the load bus are wired to the TSC 800 controller. Most transfer switches manufactured prior to December 2004 will not have the C phase load bus wiring installed and must be set for 1-phase load sensing.

5.8. STATS MENU

The STATS menu displays the recorded data logging for the following events:

NOTE:

The following stats menu is provided in TSC 800 Software version 2.0 (or higher).

- Total Number of Transfers
- Total Number of Transfers due to source failure
- Number of Hours Controller is energized
- Number of Hours Load is on Utility
- Number of Hours Load is on Generator

The TSC 800 data logging has the maximum number of events memory as follows:

- The limit for the Total Transfers and SRC Fail Transfers is 10,000.
- The limit for the Total Hours, Load On SRC1 Hours, and Load On SRC2 Hours is 160,000 hours.

LCD DISPLAY

Total Transfers 20 [®]

[®] Displays the recorded data

NOTE: Zeroing of the Statistic Records can be accessed by entering the Program Menu with a master password number. Consult THOMSON TECHNOLOGY factory for master password number if required.

6. OPERATING INSTRUCTIONS

To operate the TSC 800 controller and associated transfer switch using the front faceplate pushbuttons, refer to the following detailed operating instruction sub-section descriptions.

6.1. AUTOMATIC SEQUENCE OF OPERATION

6.1.1. NORMAL SEQUENCE OF OPERATION (OPEN TRANSITION TRANSFER)

Under normal operating conditions, the transfer switch operates automatically during a failure and restoration of utility power and does not require operator intervention.

When utility supply voltage drops below a preset nominal value (70 – 99% of rated adjustable) on any phase, an engine start delay circuit will be initiated. Following expiry of the engine start delay period (0 - 60 sec. adjustable) an engine start signal (contact closure) will be given.

Once the engine starts, the transfer switch controller will monitor the generators voltage and frequency levels. Once the generator voltage and frequency rises above preset values (70 – 99% nominal adjustable) a warm up time delay will be initiated. Once the warm up timer (0 - 3000 Sec adjustable) expires the transfer to utility supply signal will be removed (i.e. contact opening) and the transfer to generator supply signal (contact closure) will be given to the transfer switch mechanism. The load will then transfer from the utility supply (i.e. opening the utility power switching device) to the generator supply (closing the generator power switching device) to complete a break-before-make open transition transfer sequence.

The generator will continue to supply the load until the utility supply has returned and the retransfer sequence is completed as follows: When the utility supply voltage is restored to above the present values (70 - 99% of rated adjustable) on all phases, a utility return delay circuit will be initiated. Following expiry of the utility return timer (0 – 50.0 min. adjustable), the transfer to generator supply signal will be removed (contact opening), the transfer to utility supply signal (contact closure) will be given to the transfer switch mechanism. The load will then be transferred from the generator supply back to the utility supply. During the utility re-transfer sequence a neutral position delay circuit can be employed which will cause the transfer mechanism to pause in the “neutral position (i.e. with both transfer power switching devices open) for the duration of the neutral delay timer (0 -120 seconds adjustable) setting, once the time delay expires, the re-transfer sequence will be completed. The Neutral Delay Bypass feature can also be enabled to detect when all load phases voltages have dropped below 20% of the nominal system voltage, which will cancel any remaining Neutral Delay time and complete the transfer.

An engine cooldown timer circuit will be initiated once the load is transferred from the generator supply and determined to have made position by ensuring the load bus is energized and the Utility position indication confirmed. Following expiry of the cooldown delay period (0 – 50.0 min. adjustable) the engine start signal will be removed (remote start contact opened) to initiate stopping of the generator set.

6.1.2. NORMAL SEQUENCE OF OPERATION (CLOSED TRANSITION TRANSFER)

For transfer switches equipped with the closed transition transfer option, the TSC 800 is configured to provide additional logic for this application. When the TSC 800 controller receives an input signal for Closed Transition Transfer Mode (contact closing on TB2-12) the TSC 800 is configured to operate as follows:

Under normal closed transition operating conditions, the transfer switch operates automatically during a failure and restoration of utility power and does not require operator intervention.

When utility supply voltage drops below a preset nominal value (70 - 99% of nominal, adjustable) on any phase, an engine start delay circuit will be initiated. Following expiry of the engine start delay period (0 - 60 sec. adjustable) an engine start signal (contact closure) will be given.

Once the engine starts, the transfer switch controller will monitor the generator voltage and frequency levels. When the generator voltage and frequency rises above preset values (70 - 99% of nominal, adjustable) a warm up time delay will be initiated. When the warm up timer (0 – 3000 Sec. adjustable) expires the transfer to utility supply signal will be removed (logic contact(s) opening) and the transfer to generator supply signal (logic contact(s) closure) will be given to the transfer switch Power Switching Devices. The load will then transfer from the utility supply (i.e. opening the utility power switching device) to the generator supply (closing the generator power switching device) to complete a break-before-make open transition transfer sequence.

The generator will continue to supply the load until the utility supply has returned and the retransfer sequence is completed as follows: When the utility supply voltage is restored to above the present values (70 - 99% of rated adjustable) on all phases, a re-transfer sequence will be initiated once the Utility Return timer expires. The utility will close its power-switching device when it is in synchronism with the generator supply via external logic device. The generator power switching device will immediately trip open approximately 50 -100 milliseconds after the utility power switching device closes to complete the “make-before-break” re-transfer sequence.

An engine cooldown timer circuit will be initiated once the load is transferred from the generator supply and determined to have made position by ensuring the load bus is energized and the utility position indication confirmed. Following expiry of the

cooldown delay period (0.0 – 50.0 min. adjustable) the engine start signal will be removed (remote start contact opened) to initiate stopping of the generator set.

6.1.3. TEST MODE SEQUENCE OF OPERATION

6.1.3.1. TEST CONDITION (OPEN TRANSITION TRANSFER)

When an operator selects a test mode it shall signal a simulated utility power fail signal to the transfer switch controller. The transfer switch shall operate as per a normal utility power fail condition. The neutral delay circuit logic will be active during transfer to and from the generator supply (i.e. when both sources of power are available). (For definitions and added features refer to Section 7.5.12.)

The transfer switch shall remain on generator supply until the test mode is terminated. It will then re-transfer back to the utility supply and continue to operate the generator set for its cooldown period then stop.

6.1.3.2. TEST CONDITION (CLOSED TRANSITION TRANSFER)

When a load test is initiated in the closed transition transfer mode, the generator will start and following its warm up delay, the generator will close its power-switching device when it is in synchronism with the utility supply via external logic device. The utility power switching device will immediately trip open approximately 50 -100 milliseconds after the generator power-switching device closes to complete the “make-before-break” transfer sequence.

The generator will continue to supply the load until the test mode has been removed and the re-transfer sequence is completed as follows: The utility power-switching device will close when it is in synchronism with the generator supply via external logic device. The generator power-switching device will immediately trip open approximately 50 -100 milliseconds after the utility power switching device closes to complete the “make-before-break” re-transfer sequence.

6.1.4. ABNORMAL SEQUENCE OF OPERATION

6.1.4.1. GENERATOR FAILURE ON LOAD

Should the generator set fail while on load, the transfer switch shall re-transfer the load back to the utility supply if within nominal limits. The utility return timer will be bypassed in this condition.

NOTE:

This operating condition applies to a normal utility failure as well as any test condition.

6.1.4.2. TRANSFER SWITCH FAIL ALARM LOGIC

The TSC 800 controller contains logic to detect a transfer mechanism failure. Should a failure be detected, a forced transfer to the alternate supply will be initiated if the TSC 800 is programmed for force transfer. Refer to the programming Section 7.5.14 for further information in Force Transfer operation.

6.1.4.3. SERVICE ENTRANCE ATS

For Service Entrance Rated transfer switch applications, the transfer switch control logic will include external wiring to signal the transfer switch mechanism to move to the “Service Disconnected” position when Service Disconnect Operation is required. In this mode the TSC 800’s transfer control outputs and Transfer Fail feature is disabled. On return to Service the TCS 800 will display “Resuming Normal Operation” and the Power-Switching Device will be closed to the utility supply. Should the utility supply be out of limits the generator will be issued a start command and the load transfer to the generator supply once its warm-up time has expired. The ATS returns to Auto control and will return to the utility supply as previously describe for the appropriate ATS design type.

NOTE: On return to Normal Service the Engine Start output is inhibited (held up) for approximately 8 – 10 seconds. Requesting another mode of operation requiring the engine start contact to close will be ignored until this timer expires.

6.2. LCD DISPLAY OPERATION

The TSC 800 LCD display will operate in the following modes:

NOTE:

The following LCD operation is provided in TSC 800 Software version 2.0 (or higher).

- ❑ SLEEP Mode: The LCD display will automatically turn off and go in to a “sleep” mode to preserve operating life time. The sleep mode will be activated if a faceplate key press is not activated within a 16 minute time period. Pressing any faceplate key will automatically reactivate the LCD display.
- ❑ AUTO SCROLLING Mode: The LCD will automatically scroll through a series of display menu screens at a rate of 1 screen every 3 seconds. Pressing any faceplate key while the display is on the desired menu screen will automatically stop the scrolling feature. The auto-scrolling feature will be re-activated 120 seconds later if no key presses are made. To view other menus once the auto scrolling has been de-activated, press the *ENTER* or *EXIT* pushbuttons to scroll to the next available menu. NOTE that the menu list will automatically loop back to the first menu item when the end of the list is reached.
- ❑ BACK LIGHT Mode: The LCD incorporates a back light feature. When any keypad is pressed the back light will illuminate for 120 seconds.
- ❑ AUTO EXIT PROGRAMMING Mode: The LCD display will automatically exit the programming menu and return to auto scrolling mode if no keypad is depressed within 5 minutes.

6.3 TIME CLOCK ADJUSTMENT

To adjust the TSC 800 controller’s internal time clock, follow the detailed procedure below.

NOTE: Normal utility or generator control power to the controller must be available to permit adjustment.

- Using the *ENTER* or *EXIT* pushbutton, scroll to the **Program Menu**.
- Using the *INCREMENT* pushbutton, select the **Yes** message and press the *ENTER* pushbutton.
- Press the *ENTER* pushbutton when the **Password** message is displayed.
- Using the *INCREMENT* pushbutton, select the current **Day** of the week message and **week number** (1-4) and press the *ENTER* pushbutton.

NOTE:

Week Number is programmable only if the System Time Clock Rollover period is set longer than 7 days. Refer to Programming section for further details.

- Using the *INCREMENT* pushbutton, select the current **Hour** of the day (e.g. 24 hour clock) and press the *ENTER* pushbutton.
- Using the *INCREMENT* pushbutton, select the current **Minute** of the day (e.g. 60 minute) and press the *ENTER* pushbutton.
- Press the *EXIT* pushbutton and hold for 2 seconds to exit the time clock adjustment mode (Automatic exit if no keypad depressed within 5 minutes).

6.4 TEST MODES

6.4.1 OPERATOR INITIATED UTILITY POWER FAIL SIMULATION (LOAD TEST)

To perform a testing operation on the transfer switch using the front faceplate pushbuttons, follow the procedure listed below.

To Initiate the Load Test Mode:

- Using the *ENTER* pushbutton, scroll to the **ATS Mode Menu**.
- Using the *INCREMENT* pushbutton, select the **Yes** message and press the *ENTER* pushbutton.
- Using the *INCREMENT* pushbutton, select the **Onload** or **Offload** test option as required.
- Press the *ENTER* pushbutton.
- Continuous Test will be displayed (no time out). Using the *INCREMENT* pushbutton, a timed test can be selected if the desired, duration of **Test Mode Time Out** is selectable in 15-minute increments from 15 – 240 minutes.
- Press the *ENTER* pushbutton.

To Exit the Test Mode:

- Using the *ENTER* pushbutton, scroll to the **ATS Mode Menu**.
- Using the *INCREMENT* pushbutton, select the **Yes** message and press the *ENTER* pushbutton.
- Using the *INCREMENT* pushbutton, select **Auto**.
- Press the *ENTER* pushbutton. After the Utility Return Timer has expired the transfer of the load from the generator to the utility supply will be initiated.

6.4.2 AUTOMATIC PLANT EXERCISE TEST

To initiate an automatic plant exercise test mode, the TSC 800 must be pre-programmed for the desired start/stop times, frequency of the test and type of test (i.e. Onload, Offload).

Refer to the Programming section for details on programming.

Once the plant exercise timer is programmed, the engine will immediately start at the selected time and transfer on load (if Onload is selected) once nominal voltage and frequency levels have been obtained. The engine will remain operating until the stop time is reached, then the load will re-transfer back to the utility supply after the utility return timer has expired. The generator will repeat the test sequence as programmed.

6.4.3 FOUR FUNCTION REMOTE TEST (FTS4 OPTION)

The function of the Four Position Test Switch Input is to allow operators to select various operating scenarios for test or maintenance purposes, in addition to the use of the faceplate mounted pushbuttons.

NOTE: When an external FTS4 switch is used, the TSC 800 operation will be based on the highest priority of either the internal ATS Mode or the external FTS4 inputs to the controller.

Mode Priority: 1 Off, 2 Onload Test, 3 Offload Test & 4 Auto

Off: Disables the engine start output from the transfer switch (FTS4 only). TSC 800 will display "Controller Out of Service". All transfer logic outputs are dropped out (disabled). The transfer switch will not provide automatic control in the event of a power failure. Engine start output on the controller is dropped out. (Place generator controls in *OFF* if continuous running of the generator is not desired.)

NOTE: Moving FTS4 out of *OFF* will display “Resuming Normal Operation” and the ATS will source the appropriate supply.

NOTE: On return to Normal Service the Engine Start output is inhibited (held up) for approximately 8 – 10 seconds. Requesting another mode of operation during this time, which requires the engine start contact to close, will be ignored.

- Auto:** All automatic functions are enabled.
- Engine Start:** (Offload Test) An engine start signal will be initiated and will remain on until the FTS4 is placed in another position. The engine will start if the engine’s auto start controller is in the “Auto” mode. If the primary source fails in this mode, and the secondary source is within parameters, the TSC 800 will initiate a transfer to the secondary source.
- Test:** (Onload Test) A primary source failure is simulated and an engine start signal will be initiated. When the secondary source is within normal limits, the TSC 800 will initiate a transfer to the secondary source. The system will remain in this state until the FTS4 is placed in another position or the secondary supply fails. Upon a secondary supply failure, if the primary supply is available, the TSC 800 will initiate a transfer to the primary supply. The Utility Return time sequence will be initiated when the Onload Test mode is terminated. Once transfer is complete to the primary source the engine cooldown time sequence will be initiated, on expiry, the generator set will stop if no cooldown is included in its design/programming.

6.5 TRANSFER FAIL FAULT RESET

To reset a Transfer Fail condition (i.e. When the LCD Display indicates the applicable fault condition and the “Press Lamp Test” alarm message), press and hold the *DECREMENT & INCREMENT* keys simultaneously.

Once the alarm condition is reset, the load will automatically retransfer back to the original source if within normal limits.

6.6 LAMP TEST

To initiate a Lamp Test, press and hold the *DECREMENT* & *INCREMENT* keys simultaneously until all LEDs & LCD segments illuminate.

6.7 TIMER BYPASS

The following automatic sequencing time delays can be temporarily bypassed when the time function is active as shown on the TSC 800 LCD display:

NOTE:

Timer Bypass feature is provided in TSC 800 Software version 2.0 (or higher).

- Utility Return Timer
- Cooldown Timer
- Warm up Timer

This feature is typically used when testing to avoid waiting for the complete duration of the time period.

To activate the bypass function, simultaneously press the *DECREMENT* and the *ENTER* keys during the timer operation.

NOTE: The Time delay functions will return to the normal time settings on the subsequent automatic operating sequence.

6.8 MANUAL UTILITY RE-TRANSFER

If the TSC 800 is programmed to provide a Manual Utility Re-transfer Sequence, an operator must initiate the re-transfer sequence when the utility supply has returned to normal following a utility power failure and TSC 800 LCD message “Util Return” – “Press Lamp Test”.

NOTE:

Manual Re-transfer feature is provided in TSC 800 Software version 2.0 (or higher). Programmed Utility Return Delay Time is not included to ensure stable utility supply prior to retransfer.

6.9 SERVICE ENTRANCE ATS MODE

For transfer switches equipped with the Service Entrance Mode option, the TSC 800 is configured to provide additional logic for the application. When the TSC 800 controller receives an input signal for Service Entrance Mode (contact closing on TB2-15) the TSC 800 will post an alarm message on the LCD display “Service Disconnecting” when sourcing

neutral position and when both Load on Generator and Utility inputs are de-energized and the load bus is de-energized will display “Service Disconnected”. The control logic required to move the ATS mechanism to the neutral position is controlled by external logic and not by the TSC 800. When in “Service Disconnect” mode all transfer logic outputs are de-energized. When “Service Disconnect” mode is removed the controller will display “Returning to Service” and move to the appropriate source depending on availability within programmed limits.

NOTE: On return to Normal Service the Engine Start output is inhibited (held up) for approximately 8 – 10 seconds. Requesting another mode of operation during this time, which requires the engine start contact to close, will be ignored.

NOTE:

Service entrance feature is provided in TSC 800 Software version 2.0 (or higher).

6.10 PHASE BALANCE PROTECTION ALARM

When the TSC 800 is programmed with Phase Balance protection enabled, should a transfer occur due to an out of limit phase balance condition, an alarm message will be shown on the TSC 800 LCD display “UTIL (or GEN) UNBALANCED PRESS LAMP TEST”. A re-transfer back to the original source will not occur until the LAMP TEST function is activated and alarm is reset.

NOTE: if the alternate source fails, the alarm lockout will not be bypassed inhibiting the load to re-transfer back to the original source even if within limits. The reason the re-transfer is inhibited is phase unbalance is generally only detected when load is applied to the source and the condition will appear to clear when the load is removed, as such allowing a re-transfer to the failed source previously determined to have a phase balance fault will only result in multiple unnecessary transfers of the load between sources. Retransfer is set to lockout and requires operator intervention.

NOTE:

Phase balance feature is provided in TSC 800 Software version 2.0 (or higher).

7. PROGRAMMING INSTRUCTIONS

7.1. PASSWORDS

Access to the programmable parameters of the TSC 800 Transfer Controller is via a security password number. Three levels of security passwords are provided as described below:

7.1.1. READ ONLY MODE

User can view the programmable parameters only and cannot change any values. The Factory default number for the read-only mode is one (1).

7.1.2. READ / WRITE MODE

User can view and modify any programming parameter as required. The Factory default number for the read/write mode is two (2).

7.1.3. MASTER READ / WRITE MODE

User can view/modify any programming parameter as well as view/modify the security password level numbers. Consult THOMSON TECHNOLOGY factory for master password number if required.

To enter the programming mode, follow the procedure as shown:

Program Menu
Yes

Select the Program Menu by scrolling through the display screens using the *ENTER* or *EXIT* pushbuttons. When displayed, use the *INCREMENT* pushbutton to select the YES prompt and push the *ENTER* button.

Password
0

Use the *INCREMENT* or *DECREMENT* pushbuttons to ramp the displayed number up or down to the desired password access number. Press the *ENTER* pushbutton when the correct number is displayed.

NOTE:

If an invalid number is entered, programming access will be limited to time clock adjustment only. To exit the programming mode, press the EXIT pushbutton and hold for two seconds until the display scrolls rapidly.

When the programming mode is accessed, the programming parameters will be displayed in the same order as the Programming Data Sheet provided with the transfer switch. To skip over parameters that do not require changes, push and hold the *ENTER* pushbutton until the desired function is displayed. The *EXIT* pushbutton may be used to scroll backwards through the programming parameter loop, but only one keystroke at a time, maintaining it longer than 2 seconds will exit the program menu. To change a programmed parameter, use the *INCREMENT* or *DECREMENT* pushbuttons to scroll through the available options or to adjust a value up or down to the desired number. When the desired option or number is displayed, press the *ENTER* pushbutton to accept the new value. Pressing the *EXIT* pushbutton after a new value is applied will result in the new value being overwritten with the original value.

NOTE:

If the programming mode is terminated before the last change had been entered, the programming parameter will remain unchanged.

To exit the programming mode, press the *EXIT* pushbutton and hold for two seconds until the display scrolls rapidly.

7.2. EXERCISE TIMER**NOTE:**

The following exercise timer feature is provided in TSC 800 Software version 2.0 (or higher).

The TSC 800 controller has a built-in programmable exercise timer, which allows up to a 4 week (28 day), exercise time period. The timer is fully programmable for, day of week, time of day, duration of the test and type of test mode (i.e. On Load or Off Load). The exercise timer utilizes the TSC 800's internal time clock for referencing all timing functions. The time clock has a 10-minute power reserve feature to retain correct time settings during short duration

utility power failures. NOTE: During any On Load exercise test mode, the transfer switch will automatically re-transfer back to the utility supply if the generator set fails. To program the exercise timer prompts refer to the following descriptions:

7.2.1. SYSTEM TIME ROLLOVER

Select the number of days (7, 14, 21, 28) in which the system time clock will rollover for desired operation of the exercise timer. (Example - If a weekly test schedule is required at the same time; a 7-day period may be selected, this will have the test repeat each week at the same time and interval. If the generator set is to be exercised once a month, a 28-day system rollover should be selected.) The week and day of week can be selected from any one of the 4 weeks in the list, the test will then repeat at this selected time and interval.

7.2.2. AUTO TEST START DAY/WEEK NUMBER

Select the day of the week (e.g. Monday, Tuesday, etc.) and **week number** (e.g. 1-4) that the generator set is to be started to begin its exercise period.

NOTE:

Week Number is programmable only if the System Time Clock Rollover period is set longer than 7 days.

7.2.3. AUTO TEST START HOUR

Select the hour of the day (e.g. 0-23 hour) that the generator set is to be started to begin its exercise period.

7.2.4. AUTO TEST START MINUTE

Select the minute of the day (e.g. 0-59 minutes) that the generator set is to be started to begin its exercise period.

7.2.5. AUTO TEST STOP DAY/WEEK NUMBER

Select the day of the week (e.g. Monday, Tuesday, etc.) and **week number** (e.g. 1-4) that the generator set is to be stopped following its exercise period.

NOTE:

Week Number is programmable only if the System Time Clock Rollover period is set longer than 7 days. Ensure Auto Test

Stop Day/Week/Timer occurs after the Auto Test Start Day/Week/Timer setting (Generally of the same day/week) otherwise the generator may operate for an extended period of time.

7.2.6. AUTO TEST STOP HOUR

Select the hour of the day (e.g. 0-23 hour) that the generator set is to be stopped following its exercise period.

7.2.7. AUTO TEST STOP MINUTE

Select the minute of the day (e.g. 0 to 59 minutes) that the generator set is to be stopped following its exercise period.

7.2.8. AUTO TEST MODE

Select type of test mode desired. Three test modes are available as follows:

Auto: The exercise test mode is de-activated

Off Load: The generator set will be started during the exercise period but no transfer will occur.

NOTE: The generator will transfer on load if the utility supply fails during the test period.

On Load: The generator will be started and will transfer on load.

NOTE: During the On-Load exercise test mode, the transfer switch will automatically re-transfer back to the utility supply if the generator set fails.

7.3. SYSTEM CONFIGURATION

The TSC 800 controller provides a flexible control system to allow specific operation for a wide range of power distribution types. To program the system configuration, refer to the following descriptions:

7.3.1. FIRMWARE VERSION

“Display Only” - The Controller’s current firmware version number and date of release.

7.3.2. ATS MODE MENU PASSWORD (PW)

NOTE:

The following features is provided in TSC 800 Software version 2.0 (or higher). Viewable only in Master Read / Write Mode.

Allows setting of Password Protection restricting access to the ATS Mode Menu as follows:

ENABLED: Access to initiating/changing any test or operation mode requires a user-entered password. The password required will be the same as a level 2 (e.g. read/write password level or higher).

DISABLED: The ATS Mode Menu may be entered and changes made/initiated without the use of a security password.

7.3.3. UTILITY FAIL CALLOUT

NOTE:

The following features are viewable only in Master Read / Write Mode in TSC 800 Software version 2.0 (or higher).

When the remote communication option is enabled, this programming prompt will appear. This feature may be enabled or disabled by programming selection.

ENABLED: The controller will initiate a callout signal via the communication port to a remote connected device when a Utility (Source 1) power failure is detected. The callout signal will be reset when the Utility (Source 1) power returns to normal condition.

DISABLED: The controller will not initiate a callout when a Utility (Source 1) power failure is detected.

7.3.4. LOAD ON GENERATOR CALLOUT

When the remote communication option is enabled, this programming prompt will appear. This feature may be enabled or disabled by programming selection.

ENABLED: The controller will initiate a callout signal via the communication port to a remote connected device when the load is connected to the generator supply. The callout signal will be reset when the load transfers back to the utility supply.

DISABLED: The controller will not initiate a callout when the load transfers to the generator supply.

7.3.5. TRANSFER FAIL CALLOUT

When the remote communication option is enabled, this programming prompt will appear. This feature may be enabled or disabled by programming selection.

ENABLED: The controller will initiate a callout signal via the communication port to a remote connected device when the transfer switch fails to operate. The callout signal will only reset when the “Fail to Transfer” alarm is manually reset via local pushbuttons or with the remote communication software.

DISABLED: The controller will not initiate a callout when a “Fail to Transfer “ alarm condition occurs.

7.3.6. AUTO TEST CALLOUT

When the remote communication option is enabled, this programming prompt will appear. This feature may be enabled or disabled by programming selection.

ENABLED: The controller will initiate a callout signal via the communication port to a remote connected device when a automated test is initiated at the controller via the TSC 800 exercise time clock. The callout signal will reset when the Auto Test condition is terminated.

DISABLED: The controller will not initiate a callout an Auto Test condition is initiated.

7.3.7. MAN TEST CALLOUT

When the remote communication option is enabled, this programming prompt will appear. This feature may be enabled or disabled by programming selection.

ENABLED: The controller will initiate a callout signal via the communication port to a remote connected device when a manual test is initiated at the controller via the TSC 800 pushbuttons or external control switch. The callout signal will reset when the Manual Test condition is terminated.

DISABLED: The controller will not initiate a callout a Manual Test condition is initiated.

7.3.8. SWITCH NOT IN AUTO CALLOUT

When the remote communication option is enabled, this programming prompt will appear. This feature may be enabled or disabled by programming selection.

ENABLED: The controller will initiate a callout signal via the communication port to a remote connected device when the TSC 800 controllers’ operating mode is “Not In Auto” as locally selected via the four position external control switch. The callout signal will reset when the control switch is returned to the Auto position.

DISABLED: The controller will not initiate a callout if the TSC 800 controller is not in the Auto mode of operation.

7.3.9. NODE ADDRESS

Set to unique controller address (1-255) for use with network connected TSC 800 controllers.

NOTE: This programming feature is only active when the remote communication option is enabled. Default setting for single TSC 800 applications is 1.

7.3.10. SYSTEM VOLTAGE

Set to nominal system voltage as expressed in “phase to phase” voltage. (e.g. A 347/600 volt system would be entered as “600”.) The programmable range of values is 120V-15,000V.

7.3.11. VOLTAGE SENSING RATIO

For direct voltage sensing wiring connections from 208 to 600 volts, enter a ratio of “1.0:1”. When potential transformers are utilized for voltage sensing, enter the transformer ratio. (e.g. When using a 600:120 transformer, enter a ratio of “5.0:1”). The ratio is programmable in tenths to allow minor correction factors to be used for non-standard potential transformer ratios.

7.3.12. SYSTEM FREQUENCY

Set to nominal system frequency of either 50Hz or 60Hz.

7.3.13. SYSTEM PHASES

Set to match the power distribution system used on the automatic transfer switch (i.e. either single phase or 3 phase system).

7.3.14. LOAD SENSING PHASES**NOTE:**

The following feature is provided in TSC 800 Software version 2.0 (or higher).

Set to match the desired method of load bus voltage sensing required for the application (i.e. either single (1) phase or 3 phase system).

7.3.15. PHASE BALANCE**NOTE:**

The following feature is provided in TSC 800 Software version 2.0 (or higher).

Set to the desired phase balance protection for the utility and generator supply on 3 phase systems. The setting is entered on a percentage basis with a range of 3-30%. If the monitored supply voltage exceeds the programmed setpoint on any one phase, a transfer to the alternate source will be initiated following the phase balance time delay setting. To disable this feature set the percentage to zero.

NOTE:

The Phase Balance feature and program setting is only enabled when 3 phase sensing is selected.

7.3.16. PHASE BALANCE DELAY

Set to the desired time delay for the phase balance protection feature. The range of settings is 0 to 30 seconds.

NOTE:

THE PHASE BALANCE FEATURE AND PROGRAM SETTING IS ONLY ENABLED WHEN 3 PHASE SENSING IS SELECTED.

7.4. VOLTAGE SENSING

The TSC 800 controller provides 3-phase over voltage and under voltage sensing on both utility and generator supplies. Each sensor is individually programmable for pickup and dropout voltage setpoints (i.e. adjustable hysteresis) in addition to transient time delay settings. The TSC 800 controller also provides under and over frequency sensing on both utility and generator supplies. Each sensor is individually programmable for pickup and dropout frequency setpoints (i.e. adjustable hysteresis) in addition to transient time delay settings. To program the frequency sensing features, refer to the following descriptions:

To program the voltage and frequency sensing features, refer to the following descriptions:

7.4.1. UTILITY UNDER VOLTAGE SENSOR PICKUP

Set to the desired utility under voltage setpoint at which the internal voltage sensor *picks up* (i.e. the sensor energizes to a normal state when all phases of the utility phase voltages are above the setpoint). The setting is entered based on a phase-to-phase voltage value within a range of 70% to 99% of nominal system voltage. NOTE: The difference between the pickup and dropout setting is considered the dead band or hysteresis value.

7.4.2. UTILITY UNDER VOLTAGE SENSOR DROPOUT

Set to the desired utility under voltage setpoint at which the internal voltage sensor *drops out* (i.e. the sensor de-energizes to an abnormal state when any one of the utility phase voltages is below the setpoint). The setting is entered based on a phase-to-phase voltage value within a range of 70% to 99% of nominal system voltage. NOTE: The difference between the pickup and dropout setting is considered the dead band or hysteresis value.

7.4.3. UTILITY UNDER VOLTAGE SENSOR TIME DELAY (DROPOUT)

Select the desired utility under voltage time delay setting. The setting is entered in seconds within a range of 0 to 10 seconds. If no delay is required, set this time delay to zero.

7.4.4. UTILITY OVER VOLTAGE SENSOR PICKUP

Set to the desired utility over voltage setpoint at which the internal voltage sensor *picks up* (i.e. the sensor energizes to an abnormal state when any one phase of the utility voltage is above the setpoint). The setting is entered based on a phase-to-phase voltage value within a range of 101% to 200% of nominal system voltage. NOTE: The difference between the pickup and dropout setting is considered the dead band or hysteresis value.

7.4.5. UTILITY OVER VOLTAGE SENSOR DROPOUT

Set to the desired utility over voltage setpoint at which the internal voltage sensor *drops out* (i.e. the sensor de-energizes to a normal state when all phases of the utility voltage are below the setpoint). The setting is entered based on a phase-to-phase voltage value within a range of 101% to 200% of nominal system voltage. **NOTE:** The difference between the pickup and dropout setting is considered the dead band or hysteresis value.

7.4.6. UTILITY OVER VOLTAGE SENSOR TIME DELAY (PICKUP)

Select the desired utility over voltage time delay setting. The setting is entered in seconds within a range of 0 to 5 seconds. If no delay is required, set this time delay to zero.

7.4.7. UTILITY UNDER FREQUENCY SENSOR

Set to the desired utility under frequency setpoint at which the internal frequency sensor *drops out* (i.e. the sensor de-energizes to an abnormal state when the utility frequency is below the setpoint). The setting is entered in a frequency value within a range of 25.0 to 49.9Hz (for 50 Hz Systems) and 30.0 to 59.9Hz (for 60Hz Systems).

7.4.8. UTILITY UNDER FREQUENCY SENSOR TIME DELAY (DROPOUT)

Select the desired utility under frequency time delay setting. The setting is entered in seconds within a range of 0 to 10 seconds. If no delay is required, set this feature to zero.

7.4.9. UTILITY OVER FREQUENCY SENSOR

Set to the desired utility over frequency setpoint at which the internal frequency sensor *picks up* (i.e. the sensor energizes to an abnormal state when the utility frequency is above the setpoint). The setting is entered in a frequency value within a range of 50.1 to 100.0Hz (for 50 Hz Systems) and 60.1 to 120.0Hz (for 60Hz Systems).

7.4.10. UTILITY OVER FREQUENCY SENSOR TIME DELAY (PICKUP)

Select the desired utility over frequency time delay setting. The setting is entered in seconds within a range of 0 to 5 seconds. If no delay is required, set this time delay to zero.

7.4.11. GENERATOR UNDER VOLTAGE SENSOR PICKUP

Set to the desired generator under voltage setpoint at which the internal voltage sensor *picks up* (i.e. the sensor energizes to a normal state when all phases of the generator voltage are above the setpoint). The setting is entered based on a phase-to-phase voltage value within a range of 70% to 99% of nominal system voltage. **NOTE:** The

difference between the pickup and dropout setting is considered the dead band or hysteresis value.

7.4.12. GENERATOR UNDER VOLTAGE SENSOR DROPOUT

Set to the desired generator under voltage setpoint at which the internal voltage sensor *drops out* (i.e. the sensor de-energizes to an abnormal state when any one phase of the generator voltage is below the setpoint). The setting is entered based on a phase-to-phase voltage value within a range of 70% to 99% of nominal system voltage.

NOTE: The difference between the pickup and dropout setting is considered the dead band or hysteresis value.

7.4.13. GENERATOR UNDER VOLTAGE SENSOR TIME DELAY (DROPOUT)

Select the desired generator under voltage time delay setting. The setting is entered in seconds within a range of 0 to 10 seconds. If no delay is required, set this time delay to zero.

7.4.14. GENERATOR OVER VOLTAGE SENSOR PICKUP

Set to the desired generator over voltage setpoint at which the internal voltage sensor *picks up* (i.e. the sensor energizes to an abnormal state when any one phase of the generator voltage is above the setpoint). The setting is entered based on a phase-to-phase voltage value within a range of 101% to 200% of nominal system voltage.

NOTE: The difference between the pick up and drop out setting is considered the dead band or hysteresis value.

7.4.15. GENERATOR OVER VOLTAGE SENSOR DROPOUT

Set to the desired generator over voltage setpoint at which the internal voltage sensor *drops out* (i.e. the sensor de-energizes to a normal state when all phases of the generator voltage are below the setpoint). The setting is entered based on a phase-to-phase voltage value within a range of 101% to 200% of nominal system voltage.

NOTE: The difference between the pickup and dropout setting is considered the dead band or hysteresis value.

7.4.16. GENERATOR OVER VOLTAGE SENSOR TIME DELAY (PICKUP)

Select the desired generator over voltage time delay setting. The setting is entered in seconds within a range of 0 to 5 seconds. If no delay is required, set this time delay to zero.

7.4.17. GENERATOR UNDER FREQUENCY SENSOR

Set to the desired generator under frequency setpoint at which the internal frequency sensor *drops out* (i.e. the sensor de-energizes to an abnormal state when the generator frequency is below the setpoint). The setting is entered in a frequency value within a range of 25.0 to 49.9Hz (for 50 Hz Systems) and 30.0 to 59.9Hz (for 60Hz Systems).

7.4.18. GENERATOR UNDER FREQUENCY SENSOR TIME DELAY (DROPOUT)

Select the desired generator under frequency time delay setting. The setting is entered in seconds within a range of 0 to 10 seconds. If no delay is required, set this time delay to zero.

7.4.19. GENERATOR OVER FREQUENCY SENSOR

Set to the desired generator over frequency setpoint at which the internal frequency sensor *picks up* (i.e. the sensor energizes to an abnormal state when the generator frequency is above the setpoint). The setting is entered in a frequency value within a range of 50.1 to 100.0Hz (for 50 Hz Systems) and 60.1 to 120.0Hz (for 60Hz Systems).

7.4.20. GENERATOR OVER FREQUENCY SENSOR TIME DELAY (PICKUP)

Select the desired generator over frequency time delay setting. The setting is entered in seconds within a range of 0 to 5 seconds. If no delay is required, set this time delay to zero.

7.5. GENERATOR CONTROL LOGIC

The TSC 800 provides control and delay logic specific to the operation of the generator, these are:

7.5.1. COMMIT TO TRANSFER LOGIC

The TSC 800 transfer switch controller contains a “COMMIT TO TRANSFER” logic selection feature. This feature is user programmable and allows 2 different functional settings which are described below:

DISABLED: The transfer switch will not commit to transfer after the engine start delay has expired.“

ENABLED: The transfer switch will commit to transfer after the engine start delay has expired.“ Selecting the “ENABLED” mode will prevent numerous engine starting and stopping sequences if the utility supply is continuously fluctuating beyond the pre-set limits. The feature is automatically cancelled

after 5 minutes should the generator fails to start or can be manually cancelled by placing the ATS Menu Mode in “OFF” and then back to Auto.

7.5.2. GENERATOR START DELAY

The generator (i.e. engine) start signal will be initiated following expiry of the start delay timer. Select desired generator start delay time in seconds. The range of setting is 0 to 60 seconds. If no delay is required, set this time delay to zero. **NOTE:** The output relay is normally energized when the utility power is within limits and de-energizes to start the generator.

7.5.3. GENERATOR WARMUP DELAY

A transfer to the generator supply will be initiated when the voltage and frequency are within limits and upon expiry of the warm-up delay timer. Select desired generator warm-up delay time in seconds. The range of settings is 0 to 3000 seconds. If no delay is required, set this time delay to zero.

7.5.4. GENERATOR COOLDOWN DELAY

The generator (i.e. engine) cooldown period will be initiated once the load has transferred from the generator supply. The engine start signal will be maintained until expiry of the cooldown delay timer. Select desired generator cooldown delay time in minutes. The range of settings is 0.0 to 50.0 minutes. If no delay is required, set this time delay to zero. Cooldown time is posted in 1-second decrements when active.

7.5.5. PRE-TRANSFER DELAY (LDC)

The pre-transfer delay period will be initiated upon an impending transfer in either direction from a powered-to-powered source. The pre-transfer output relay will momentarily energize (as per the pre-transfer time setting) prior to a load transfer and will stay energized until the post-transfer delay time commences. Select desired pre-delay time in seconds. The range of settings is 0 to 300 seconds. If no delay is required, set this time delay to zero.

7.5.6. POST-TRANSFER DELAY (LDC)

The post-transfer delay period will be initiated expiry of the pre-transfer delay (overlapping) in either direction. The post-transfer output relays will energize (as per the post-transfer time setting) after the load transfer and will stay energized until the post-transfer delay time period expires. Select desired post-delay time in seconds. The range of settings is 0 to 300 seconds. If no delay is required, set this time delay to zero.

7.5.7. TRANSFER LOGIC

NOTE: This feature is user selectable in TSC 800 software version 1.3 (or greater). The TSC 800 transfer controller software contains a user selectable function for type of transfer logic required for specific applications. This feature will be factory set for specific type of application and transfer mechanism used and therefore should not require resetting.

Selectable operating logic is as follows:

MAINTAINED: The TSC 800 transfer output signals will stay in the ‘MAINTAINED’ energized state upon a source failure and will only de-energize when the alternate source becomes available. **NOTE:** the transfer output signal will de-energize upon a total loss of source voltage.

DROPOUT: The TSC 800 transfer output signals will “DROPOUT” (or de-energize) when the connected source goes out of normal voltage or frequency limits. The transfer output signal will only re-energize when the connected source returns to normal limits.

7.5.8. LOAD ON UTILITY PROGRAMMABLE OUTPUT

NOTE:

The following Programmable output features are provided in TSC 800 Software version 2.0 (or higher).

The TSC 800 transfer controller output on terminal TB3-2 may be programmed for different control functions. The powered output is supplied from the Utility supply and must be used accordingly. The following programmable functions are available:
NOTE: Only one function may be programmed.

LOAD ON UTILITY	Output energizes when the utility transfer power-switching device is closed.
UTILITY NORMAL	Output energizes when the utility supply is energized and is within nominal voltage and frequency limits.
DELAYED TRANSFER	Output will energize “X” seconds following a Transfer to Utility logic signal. The time period is programmable 0-30 seconds.

7.5.9. LOAD ON GENERATOR PROGRAMMABLE OUTPUT

NOTE:

The following Programmable output features are provided in TSC 800 Software version 2.0 (or higher).

The TSC 800 transfer controller output on terminal TB3-7 may be programmed for different control functions. The powered output is supplied from the Generator supply and must be used accordingly. The following programmable functions are available:

NOTE: Only one function may be programmed.

LOAD ON GENERATOR	Output energizes when the generator transfer power-switching device is closed.
GENERATOR NORMAL	Output energizes when the generator supply is energized and is within nominal voltage and frequency limits.
DELAYED TRANSFER	Output will energize “X” seconds following a Transfer to generator logic signal. The time period is programmable 0-30 seconds.

7.5.10. MAXIMUM FIND NEUTRAL DELAY

The TSC 800 transfer control logic includes an adjustable time delay feature to compensate for the maximum time that a transfer switch mechanism takes to operate when load-sensing voltage is used to detect the neutral position. This time delay is set to a time value, which is *greater than* the typical time that the transfer mechanism typically takes to operate from one supply position to the neutral position. When the TSC 800 controller is supplied from the factory with a Thomson Technology transfer mechanism the Maximum Find Neutral Delay will be factory set for correct operation.

NOTE: When the TSC 800 controller is supplied loose without a transfer mechanism, the Maximum Find Neutral Delay function must be user set for correct operation with the applicable transfer mechanism. For applications using electrically held contactors, the Maximum Find Neutral Delay function must typically be set for 0.0 seconds for correct operation.

7.5.11. NEUTRAL DELAY TIMER (NDT)

The neutral delay time period will be initiated once both of the supply power-switching devices are open during a transfer sequence. Select desired neutral delay time in seconds. The range of settings is 0 to 60 seconds. If no delay is required, set this time

delay to zero. **NOTE:** The neutral delay may be bypassed should the operating power fail for longer than the timer setting.

7.5.12. NEUTRAL DELAY BYPASS

The TSC 800 transfer switch controller contains a “NEUTRAL DELAY BYPASS” logic, which allows a shorter neutral delay period during transfer if the load bus voltage falls to safe levels before the transfer sequence is completed. This feature is user programmable and allows 2 different functional settings which are described below:

DISABLED: The transfer switch neutral delay period will operate as per the Neutral Delay Timer setting.

ENABLED: The transfer switch neutral delay period will be bypassed if the load bus voltage falls to safe levels before the transfer sequence is completed.

7.5.13. MAXIMUM TRANSFER TIME

The TSC 800 transfer control logic includes an adjustable time delay feature to detect when a transfer switch mechanism fails to operate. This time delay is set to a time value which is *greater than* the typical time that the transfer mechanism typically takes to operate from one supply position to the opposite supply position. This feature is factory set to match the specific transfer switch mechanism as supplied with the unit.

7.5.14. TRANSFER FAIL

The TSC 800 transfer switch controller contains a “TRANSFER SWITCH FAIL” detection feature. This feature is user programmable and allows 3 different functional settings which are described below:

DISABLED: The “TRANSFER SWITCH FAIL” feature is disabled in this mode. The TSC 800 controller will not verify that the transfer mechanism has operated correctly.

HALT TRANSFER: The TSC 800 controller will verify that the transfer switch mechanism has correctly transferred or is in the correct position. If the TSC 800 controller senses an abnormal condition (i.e. load voltage and transfer switch position contacts are not at the normal levels or states) the controller will activate an alarm message to the LCD display. The transferring output signals from the controller will be de-activated and the engine start contact will remain in its last state (before the alarm was activated). The controller has an internal 30-second timer to provide an alarm bypass to enable correct operating sequences. To reset the alarm condition, the “lamp test” function must be activated.

FORCE TRANSFER: The TSC 800 controller will verify that the transfer switch mechanism has correctly transferred or is in the correct position. If the TSC 800 controller senses an abnormal condition (i.e. fail to transfer when initiated, load voltage failure due to a tripped transfer power-switching device or transfer switch limit switch failure) the controller will activate an alarm message to the LCD display. The transferring output signals from the controller will be enabled and will force a transfer to the alternate source if available and within nominal limits. The transfer switch will remain on the alternate source indefinitely until the “Transfer Fail” alarm condition is manually reset on the TSC 800 controller. The controller has an internal 30-second timer to provide an alarm bypass to enable correct operating sequences. To reset the alarm condition, the “lamp test” function must be activated.

NOTE: The Thomson Technology factory default setting for the TSC 800 “Transfer Switch Fail” function is **FORCE TRANSFER**.

7.5.15. MANUAL UTILITY TRANSFER RETURN

The TSC 800 transfer switch controller contains a “MANUAL UTILITY TRANSFER RETURN” feature, which allows an operator initiated re-transfer sequence to occur when utility power has returned following a power failure. This feature is user programmable and allows 2 different functional settings which are described below:

DISABLED: The transfer switch will automatically re-transfer back to the utility supply if within nominal pre-programmed limits and following expiry of the Utility Return Timer.

ENABLED: The transfer switch will remain on the generator supply until system operators manually initiate the re-transfer sequence. Press Lamp Test to initiate the transfer sequence. **NOTE:** The transfer switch will automatically re-transfer back to the utility supply if the generator supply fails.

7.5.16. UTILITY RETURN DELAY

The utility return delay period will be initiated once the utility supply has returned within limits following a utility power failure condition. Select desired utility return delay time in minutes. The range of settings is 0.0 to 50.0 minutes. If no delay is required, set this time delay to zero. **NOTE:** The utility return delay will be bypassed should the generator fail during the time delay period.

7.5.17. MAX SYNC TIME

The TSC 800 transfer control logic includes an adjustable time delay for maximum synchronizing time for Closed Transition type automatic transfer Switches. If the selected time expires before the transfer switch sources are synchronized, the Transfer Fail logic will be initiated. Select desired time in minutes. The range of settings is 1 to 10 minutes (displays in 1 second decrements when timer active). This feature is only operative when the TSC 800 Closed Transition Input (TB2-12) is activated.

7.5.18. MAX_POWER SWITCHING DEVICE OPEN TIME

The TSC 800 transfer control logic includes an adjustable time delay for maximum allowable time both source power-switching devices can remain closed (in parallel) before opening on a Closed Transition type automatic transfer Switch (detects for a “fail to separate” condition). If the selected time expires before the transfer switch power-switching device opens (sources being separated from), the Transfer Fail logic will be initiated. Select desired time in seconds. The range of settings is 1 to 3 seconds. This feature is only active when the TSC 800 Closed Transition Input (TB2-12) is activated.

7.5.19. PROGRAMMABLE OUTPUT

The TSC 800 transfer controller includes a standard programmable output relay signal. The output relay energizes when one of the following conditions occurs. NOTE: Only one function may be programmed.

LOAD ON UTIL	Output energizes when the utility transfer power-switching device is closed and load voltage is present.
LOAD ON GEN	Output energizes when the generator transfer power-switching device is closed and load voltage is present.
LOAD SHED	Output energizes when generator is on load and frequency drops below under frequency setpoint for longer than the time delay setting.
FAIL TO TRANSFER	Output relay energizes when the transfer switch mechanism fails to operate for the given time delay period. NOTE: This output feature is only activated when the “TRANSFER SWITCH FAIL” feature is set to either “Halt” or “Force” transfer settings.

NOTE:

The following Programmable output features are provided in TSC 800 Software version 2.0 (or higher).

UTIL NORMAL	Output relay energizes when the utility supply is energized and is within programmed voltage, frequency and phase balance limits on all phases.
GEN NORMAL	Output relay energizes when the generator supply is energized and is within programmed voltage, frequency and phase balance limits on all phases.
ATS NOT IN AUTO	Output relay energizes when the TSC 800 operating mode is not in the AUTO operating mode. This condition will occur when the external switch (e.g. FTS4) or internal Test Modes is programmed in any other mode other than Auto.
2nd ENGINE START	Output relay de-energizes when the TSC 800 signal an engine start operation due to a failed Utility supply or activated Test mode.
UTIL and GEN NORMAL	Output relay energizes when the generator supply <u>and</u> utility supply are both energized and are within programmed voltage, frequency and phase balance limits on all phases.

7.6. VOLTAGE SENSING CALIBRATION

The TSC 800 software program provides voltage-sensing calibration for the utility, generator and load sensors. All voltage-sensing circuits are factory calibrated to specific voltage levels prior to shipment of the transfer switch. Recalibration in the field is rare and in most cases only the Span Calibration needs minor adjustment. Zero calibration should only be undertaken by qualified personnel due to the nature of the requirements to achieve proper zeroing, factory zero calibration should provide accurate readings with no adjustments required. Zero calibration is only required on first time setup of new software where zero correction factors

are unknown. Using the original correction factors determined at the factory as noted on the supplied Program Data Sheets can be reapplied as these values are associated to sensing resistor error factors of the TSC 800 circuit board (not a software offset).

Should field calibration of any voltage-sensing circuitry be required, the following procedure may be used.

WARNING

Voltage sensing circuits are capable of lethal voltages while energized. Standard safety procedures should be followed and be performed by qualified personnel only. Failure to do so may cause personnel injury and/or death.

7.6.1. GENERAL

7.6.1.1. To access the TSC 800's software programming loop for programming, the program menu must be selected, the Yes prompt entered and the Read/Write Security Mode password number (or higher) must be entered.

7.6.1.2. Once the programming loop has been accessed, scroll to the voltage calibration screens as shown below.

UTIL AB^① ZERO^②	
127^③	600V^④

- ① Displays the selected supply's phase voltages to be calibrated.
- ② Displays the type of calibration function, either ZERO or SPAN.
- ③ Displays the calibration correction factor number (0-255) used to obtain the correct voltage reading. **NOTE:** To correctly calibrate any of the voltage sensors, the ZERO function must be calibrated before the SPAN function. A calibration correction factor number of 127 is typical of no correction offset being applied, decreasing this value will apply a negative offset and increasing this value will apply a positive offset.
- ④ Displays the actual voltage measurement, which will be the same value as shown on the TSC 800 display menus for generator or utility supplies. This voltage reading may be calibrated higher or lower by changing the correction

factor number and compared to a meter of known calibration to be within 0.5% or better and adjusted to match.

NOTE:

To accurately calibrate the TSC 800's voltage sensors, an external test voltage meter is required, with an accuracy of 0.5% or better.

7.6.2. UTILITY VOLTAGE CALIBRATION

To adjust the utility supply voltage sensors, perform the following procedure:

7.6.2.1. ZERO CALIBRATION

7.6.2.1.1. Energize the generator supply to power up the controller and de-energize the utility supply.

7.6.2.1.2. Scroll to the desired utility supply voltage phases with the **ZERO** function selected. **NOTE:** The phases being calibrated for zero must have a true zero reference to ground to allow proper calibration. A zero voltage reference should be achieved as a result of a near 0 ohms resistance through the source supply windings through to the neutral star point connection which in turn is solidly bonded to the building ground at one point in the system (where both the step down sensing and power supply transformers are supplied with the transfer switch the ground reference is provided by the these transformers and no further actions are required). Where this ground reference path does not exist a true zero voltage reference may not be achievable (upstream breaker ahead of the TSC 800 open in respect to the building utility supply transformer) as this leaves the sensing inputs to the TSC 800 floating. In cases such as this the TSC 800 sensing inputs for the Utility supply must temporarily be grounded to provide this true zero reference. It is imperative, should this work be undertaken, it only is preformed by qualified personnel and that the shorting leads be removed before re-energizing the circuit. Failure to do so will result in catastrophic equipment failure and possible personnel injury and/or death.

7.6.2.1.3. Use the *INCREMENT* or *DECREMENT* pushbuttons to adjust the correction factor number while observing the displayed

voltage level. Adjust the correction factor number to obtain 0VAC on the display.

7.6.2.1.4. With the correct voltage displayed, press the *ENTER* pushbutton to accept the correction factor number. Record the correction factor number on the TSC 800 programming sheet for future reference if required.

7.6.2.1.5. Repeat the above procedure for Zero Calibration for all remaining phases of the utility supply as required. Remove any shorting leads for zeroing purposes before proceeding.

7.6.2.2. SPAN CALIBRATION

7.6.2.2.1. Energize the utility supply voltage to the controller at nominal level. The generator supply may be de-energized.

7.6.2.2.2. In the programming mode, scroll to the desired utility supply voltage phases with the **SPAN** function selected (**do not** adjust the Zero calibration function with voltage applied as this will result in non-linear voltage readings).

7.6.2.2.3. Connect an external AC voltmeter of adequate voltage range and accuracy to the TSC 800 controller terminal associated with the voltage phases to be calibrated.

WARNING

Voltage sensing circuits are capable of lethal voltages while energized. Standard safety procedures should be followed and be performed by qualified personnel only. Failure to do so may cause personal injury and/or death.

7.6.2.2.4. Use the *INCREMENT* or *DECREMENT* pushbuttons to adjust the correction factor number while observing the displayed voltage level on the TSC 800. Adjust the correction factor number to obtain an identical voltage reading as measured with the external AC voltmeter. To attain the highest degree of calibration accuracy for the Span, adjust the correction factor to attain a TSC 800 voltage value of 1 volt above and 1 volt below the actual value, in each case note the correction factor number required to attain these values, select the correction number mid point between these two values and apply this value.

7.6.2.2.5. With the correct voltage displayed, press the *ENTER* pushbutton to accept the correction factor number. Record the correction factor number on the TSC 800 programming sheet for future reference if required.

7.6.2.2.6. Repeat the above procedures for all remaining phases of the utility supply as required.

NOTE:

Once the span calibration setting has been done, do not readjust any zero calibration points as this will cause incorrect voltage readings.

7.6.3. GENERATOR VOLTAGE CALIBRATION

To adjust the generator supply voltage sensors, perform the following procedure:

7.6.3.1. ZERO CALIBRATION

7.6.3.1.1. Energize the utility supply to power up the controller and de-energize the generator supply.

7.6.3.1.2. Scroll to the desired generator supply voltage phases with the **ZERO** function selected. **NOTE:** The phases being calibrated for zero must have a true zero reference to ground to allow proper calibration. A zero voltage reference should be achieved as a result of a near 0 ohms resistance through the source supply windings through to the neutral star point connection which in turn is solidly bonded to the building ground at one point in the system (where both the step down sensing and power supply transformers are supplied with the transfer switch the ground reference is provided by the these transformers and no further actions are required). Where this ground reference path does not exist a true zero voltage reference may not be achievable (upstream breaker ahead of the TSC 800 is open with respect to the generator set alternator windings), as this leaves the sensing inputs to the TSC 800 floating. Simply closing the local generator breaker will generally provide the zero voltage reference required. If this is not possible the TSC 800 sensing inputs for the generator must be temporarily grounded to provide this true zero reference. It is imperative, should this work be undertaken, it only is preformed by qualified personnel and that the shorting leads be removed before re-energizing the circuit. Failure to do

so will result in catastrophic equipment failure and possible personnel injury and/or death.

7.6.3.1.3. Use the INCREMENT or DECREMENT pushbuttons to adjust the correction factor number while observing the displayed voltage level. Adjust the correction factor number to obtain 0VAC on the display.

7.6.3.1.4. With the correct voltage displayed, press the ENTER pushbutton to accept the correction factor number. Record the correction factor number on the TSC 800 programming sheet for future reference if required.

7.6.3.1.5. Repeat the above procedure for all remaining phases of the generator supply as required.

7.6.3.2. SPAN CALIBRATION

7.6.3.2.1. Energize the utility supply voltage to the controller at nominal level. The generator supply may be de-energized.

7.6.3.2.2. In the programming mode, scroll to the desired generator supply voltage phases with the **SPAN** function selected.

7.6.3.2.3. Connect an external AC voltmeter of adequate voltage range and accuracy to the TSC 800 controller terminal associated with the voltage phases to be calibrated.

WARNING

Voltage sensing circuits are capable of lethal voltages while energized. Standard safety procedures should be followed and be performed by qualified personnel only. Failure to do so may cause personal injury and/or death.

7.6.3.2.4. Use the INCREMENT or DECREMENT pushbuttons to adjust the correction factor number while observing the displayed voltage level on the TSC 800. Adjust the correction factor number to obtain an identical voltage reading as measured with the external AC voltmeter. To attain the highest degree of calibration accuracy for the Span, adjust the correction factor to attain a TSC 800 voltage value of 1 volt above and 1 volt below the actual value, in each case note the correction factor number required to attain these values, select the

correction number mid point between these two values and apply this value.

7.6.3.2.5. With the correct voltage displayed, press the *ENTER* pushbutton to accept the correction factor number. Record the correction factor number on the TSC 800 programming sheet for future reference if required.

7.6.3.2.6. Repeat the above procedures for all remaining phases of the generator supply as required.

NOTE:

Once the span calibration setting has been done, do not readjust any zero calibration points as this will cause incorrect voltage readings.

7.6.4. LOAD VOLTAGE CALIBRATION

To adjust the load voltage sensors, perform the following procedure:

7.6.4.1. ZERO CALIBRATION

7.6.4.1.1. Energize the utility supply but keep the transfer mechanism in the neutral position (i.e. Load Bus De-energized.)

7.6.4.1.2. Scroll to the desired load supply voltage phases with the **ZERO** function selected. **NOTE:** The phases being calibrated for zero must have a true zero reference to ground to allow proper calibration. A zero voltage reference will not likely be available if there are no connected loads which result of a near 0 ohms resistance through to ground (where step down sensing transformers are supplied with the transfer switch the ground reference is provided by the these transformers and no further actions are required). Where this ground reference path does not exist a true zero may not be achievable, as the load sensing inputs to the TSC 800 will be floating. If this ground path does not exist the TSC 800 sensing inputs for the load bus must be temporarily grounded to provide this true zero reference. It is imperative, should this work be undertaken, it is only preformed by qualified personnel and that the shorting leads be removed before re-energizing the circuit. Failure to do so will result in catastrophic equipment failure and possible personnel injury and/or death.

7.6.4.1.3. Use the **INCREMENT** or **DECREMENT** pushbuttons to adjust the correction factor number while observing the displayed voltage level. Adjust the correction factor number to obtain 0VAC on the display.

7.6.4.1.4. With the correct voltage displayed, press the **ENTER** pushbutton to accept the correction factor number. Record the correction factor number on the TSC 800 programming sheet for future reference if required.

7.6.4.1.5. Repeat the above procedure for all remaining phases of the generator supply as required.

7.6.4.2. SPAN CALIBRATION SPAN CALIBRATION

7.6.4.2.1. Energize the utility supply voltage to the controller at nominal level. The generator supply may be de-energized.

7.6.4.2.2. In the programming mode, scroll to the desired generator supply voltage phases with the **SPAN** function selected.

7.6.4.2.3. Connect an external AC voltmeter of adequate voltage range and accuracy to the TSC 800 controller terminal associated with the voltage phases to be calibrated.

WARNING

Voltage sensing circuits are capable of lethal voltages while energized. Standard safety procedures should be followed and be performed by qualified personnel only. Failure to do so may cause personal injury and/or death.

7.6.4.2.4. Use the **INCREMENT** or **DECREMENT** pushbuttons to adjust the correction factor number while observing the displayed voltage level on the TSC 800. Adjust the correction factor number to obtain an identical voltage reading as measured with the external AC voltmeter. To attain the highest degree of calibration accuracy for the Span, adjust the correction factor to attain a TSC 800 voltage value of 1 volt above and 1 volt below the actual value, in each case note the correction factor number required to attain these values, select the

correction number mid point between these two values and apply this value.

7.6.4.2.5. With the correct voltage displayed, press the *ENTER* pushbutton to accept the correction factor number. Record the correction factor number on the TSC 800 programming sheet for future reference if required.

7.6.4.2.6. Repeat the above procedures for all remaining phases of the generator supply as required.

7.6.4.2.7.

NOTE:

Once the span calibration setting has been done, do not readjust any zero calibration points as this will cause incorrect voltage readings.

8. TSC 800 PROGRAMMING DATA SHEETS



**TSC 800
MICROPROCESSOR TRANSFER SWITCH CONTROLLER
SUMMARY CONFIGURATION DATA SHEET**

FIRMWARE VERSION: TSC v2.0 ATS

WORK ORDER: W-123456	REV.: 0	REV. DATE: 04/12/14	
	CUSTOMER:	DEFAULT PROGRAM: 800_V20_M240	
INITIATED BY:	PROJECT NAME		
DATE: 04/12/14	NOTES:		

SYSTEM AC INPUTS

SYSTEM AC VOLTS: 240 PHASES: 1 FREQUENCY: 60

DIGITAL DISPLAY FEATURES

<input checked="" type="checkbox"/> GENERATOR AC VOLTAGE	<input checked="" type="checkbox"/> UTILITY AC VOLTAGE	<input checked="" type="checkbox"/> TIME CLOCK
<input checked="" type="checkbox"/> GENERATOR FREQUENCY	<input checked="" type="checkbox"/> UTILITY FREQUENCY	

STANDARD FEATURES

GENERATOR WARM UP TIMER
 GENERATOR START DELAY TIMER
 GENERATOR COOLDOWN TIMER
 3 PHASE GENERATOR UNDER/OVER VOLTAGE SENSING
 GENERATOR UNDER/OVER FREQUENCY SENSING
 3 PHASE UTILITY UNDER/OVER VOLTAGE SENSING
 GENERATOR OVER VOLTAGE SENSING
 UTILITY UNDER/OVER FREQUENCY SENSING
 UTILITY RETURN TIMER
 3 PHASE UTILITY UNDERVOLTAGE SENSING
 NEUTRAL DELAY TIMER
 INTERNAL FTS4 SWITCH WITH PW PROTECT
 COMMUNICATION
 MANUAL TEST
 AUTO EXERCISE TIMER

STANDARD PROGRAMMABLE OUTPUTS

OUTPUT NAME	OUTPUT FUNCTION
PROGRAMMABLE OUTPUT	LoadOnGen

Printed 04/12/15



Indicates changes from the default program

Page 1 of 4

TSC 800 TRANSFER SWITCH CONTROLLER

WORK ORDER: W-123456	REV.: 0	REV. DATE: 04/12/14
	CUSTOMER:	DEFAULT PROGRAM: 800_V20_M240
INITIATED BY:	PROJECT NAME	
DATE: 04/12/14	NOTES:	

PARAMETER	DESCRIPTION	VALUE	RANGE
ATSMoDe	ATS MODE	<input type="checkbox"/> Auto	
ATSMoDeTimeoUt	ATS MODE TIMEOUT	<input type="checkbox"/>	
FirmwaReVerSiOn	FIRMWARE VERSION	<input type="checkbox"/> V2.0 04/12/03	
ATSMoDeMenuPW	ATS MODE MENU PASSWORD	<input type="checkbox"/> Disabled	
ReSeTStaTs	RESET STATISTICS	<input type="checkbox"/> NO	(Enter 85 to clear)
CALLOUTS			
UtilFaIlCalloUt	UTILITY FAIL CALLOUT	<input type="checkbox"/> Disabled	
LoaDOnGeNCalloUt	LOAD ON GENERATOR CALLOUT	<input type="checkbox"/> Disabled	
TranSferFaIlCalloUt	TRANSFER FAIL CALLOUT	<input type="checkbox"/> Disabled	
SwItchNotInAutoCalloUt	SWITCH NOT IN AUTO CALLOUT	<input type="checkbox"/> Disabled	
MenuNotInAutoCalloUt	MENU NOT IN AUTO CALLOUT	<input type="checkbox"/> Disabled	
AutoTeStCalloUt	AUTO TEST CALLOUT	<input type="checkbox"/> Disabled	
EXERCISE TIMER			
SystemTimeRollover	SYSTEM TIME ROLLOVER	<input type="checkbox"/> 7 Day	7/14/21/28 Days
AutoTeStStarTDay	AUTO TEST START DAY	<input type="checkbox"/> Wednesday1	Day Of Week
AutoTeStStarTHour	AUTO TEST START HOUR	<input type="checkbox"/> 10	0-23 HOUR
AutoTeStStarTMin	AUTO TEST START MIN	<input type="checkbox"/> 00	0-59 MIN
AutoTeStStoPtDay	AUTO TEST STOP DAY	<input type="checkbox"/> Wednesday1	Day Of Week
AutoTeStStoPtHour	AUTO TEST STOP HOUR	<input type="checkbox"/> 10	0-23 HOUR
AutoTeStStoPtMin	AUTO TEST STOP MIN	<input type="checkbox"/> 30	0-59 MIN
AutoTeStMoDe	AUTO TEST MODE	<input type="checkbox"/> Auto	Auto/Offload/Onload
SYSTEM CONFIGURATION			
Node Address	NODE ADDRESS	<input type="checkbox"/> 1	0-255 #
SystemVoltage	SYSTEM VOLTAGE	<input type="checkbox"/> 240	120-15,000 VAC
VoltageSensingRatio	VOLTAGE SENSING RATIO	<input type="checkbox"/> 1.0	0.0-209.0 RATIO
SystemFrequency	SYSTEM FREQUENCY	<input type="checkbox"/> 60	50/60
SystemPhases	SYSTEM PHASES	<input checked="" type="checkbox"/> 1	1/3
LoadSensingPhases	LOAD SENSING PHASES	<input type="checkbox"/> 3	1/3
PhaseBalance	PHASE BALANCE	<input type="checkbox"/> 6	0-30 %
PhaseBalanceDelay	PHASE BALANCE DELAY	<input type="checkbox"/> 10	0-30 SEC

Printed 04/12/15



Indicates changes from the default program

Page 2 of 4

TSC 800 TRANSFER SWITCH CONTROLLER

WORK ORDER: W-123456	REV.: 0	REV. DATE: 04/12/14
	CUSTOMER:	DEFAULT PROGRAM: 800_V20_M240
INITIATED BY:	PROJECT NAME	
DATE: 04/12/14	NOTES:	

UTILITY UNDERVOLTAGE			
UtilUnderVoltPU	UTILITY UNDERVOLTAGE SENSORS PICKUP	<input type="checkbox"/> 216	120-239 VAC
UtilUnderVoltDO	UTILITY UNDERVOLTAGE SENSORS DROPOUT	<input type="checkbox"/> 192	120-239 VAC
UtilUnderVoltDODelay	UTILITY UNDERVOLTAGE SENSORS TIME DELAY DROPOUT	<input type="checkbox"/> 1	1-10 SEC
UTILITY OVERVOLTAGE			
UtilOverVoltPU	UTILITY OVERVOLTAGE SENSORS PICKUP	<input type="checkbox"/> 264	241-480 VAC
UtilOverVoltDO	UTILITY OVERVOLTAGE SENSORS DROPOUT	<input type="checkbox"/> 259	241-480 VAC
UtilOverVoltPUDelay	UTILITY OVERVOLTAGE SENSORS TIME DELAY PICKUP	<input type="checkbox"/> 5	0-5 SEC
UTILITY UNDER AND OVER FREQUENCY SENSORS			
UtilUnderFreq	UTILITY UNDER FREQUENCY SENSORS	<input type="checkbox"/> 59.0	30.0-59.9 HZ
UtilUnderFreqDODelay	UTILITY UNDER FREQUENCY SENSORS TIME DELAY DROPOUT	<input type="checkbox"/> 1	0-10 SEC
UtilOverFreq	UTILITY OVER FREQUENCY PICKUP	<input type="checkbox"/> 61.0	60.1-120.0 HZ
UtilOverFreqPUDelay	UTILITY OVER FREQUENCY SENSORS TIME DELAY PICKUP	<input type="checkbox"/> 1	0-5 SEC
GENERATOR UNDERVOLTAGE			
GenUnderVoltPU	GENERATOR UNDERVOLTAGE SENSORS PICKUP	<input type="checkbox"/> 216	120-239 VAC
GenUnderVoltDO	GENERATOR UNDERVOLTAGE SENSORS DROPOUT	<input type="checkbox"/> 192	120-239 VAC
GenUnderVoltDODelay	GENERATOR UNDERVOLTAGE SENSORS TIME DELAY DROPOUT	<input type="checkbox"/> 5	1-10 SEC
GENERATOR OVERVOLTAGE			
GenOverVoltPU	GENERATOR OVERVOLTAGE SENSORS PICKUP	<input type="checkbox"/> 264	241-480 VAC
GenOverVoltDO	GENERATOR OVERVOLTAGE SENSORS DROPOUT	<input type="checkbox"/> 259	241-480 VAC
GenOverVoltPUDelay	GENERATOR OVERVOLTAGE SENSORS TIME DELAY PICKUP	<input type="checkbox"/> 5	0-5 SEC
GENERATOR UNDER/OVERFREQUENCY FREQUENCY SENSORS			
GenUnderFreq	GENERATOR UNDER FREQUENCY SENSORS DROPOUT	<input type="checkbox"/> 57.0	30.0-59.9 HZ
GenUnderFreqDODelay	GENERATOR UNDER FREQUENCY SENSORS TIME DELAY DROPOUT	<input type="checkbox"/> 5	0-10 SEC
GenOverFreq	GENERATOR OVER FREQUENCY SENSORS PICKUP	<input type="checkbox"/> 63.0	60.1-120.0 HZ
GenOverFreqPUDelay	GENERATOR OVER FREQUENCY SENSORS TIME DELAY PICKUP	<input type="checkbox"/> 5	0-5 SEC

Printed 04/12/15



Indicates changes from the default program

Page 3 of 4

WORK ORDER: W-123456	REV.: 0	REV. DATE: 04/12/14
	CUSTOMER:	DEFAULT PROGRAM: 800_V20_M240
INITIATED BY:	PROJECT NAME	
DATE: 04/12/14	NOTES:	

GENERATOR CONTROL LOGIC			
CommitToTransfer	GENERATOR COMMIT TO TRANSFER	<input type="checkbox"/>	Disabled
GenStartDelay	GENERATOR START DELAY	<input type="checkbox"/>	2 0-60 SEC
GenWarmupDelay	GENERATOR WARM-UP DELAY	<input type="checkbox"/>	2 0-3,000 SEC
GenCooldownDelay	GENERATOR COOLDOWN DELAY	<input type="checkbox"/>	2.0 0.0-50.0 MIN
ELEVATOR DELAY LOGIC			
PretransferDelay	PRE-TRANSFER DELAY	<input type="checkbox"/>	0 0-300 SEC
PosttransferDelay	POST TRANSFER DELAY	<input type="checkbox"/>	0 0-300 SEC
ATS MECHANISM LOGIC			
TransferOutputLogic	TRANSFER OUTPUT LOGIC	<input type="checkbox"/>	Maintain
LoadOnUtilOutput	LOAD ON UTILITY OUTPUT	<input type="checkbox"/>	UtilNormal
UtilTransferDelay	UTILITY TRANSFER DELAY	<input type="checkbox"/>	0.0 0.0-30.0 SEC
LoadOnGenOutput	LOAD ON GENERATOR OUTPUT	<input type="checkbox"/>	GenNormal
GenTransferDelay	GENERATOR TRANSFER DELAY	<input type="checkbox"/>	0.0 0.0-30.0 SEC
MaxFindNeutralTime	MAXIMUM FIND NEUTRAL TIME	<input type="checkbox"/>	6.0 0.0-20.0 SEC
NeutralDelay	NEUTRAL DELAY	<input type="checkbox"/>	3 0-120 SEC
NeutralDelayBypass	NEUTRAL DELAY BYPASS	<input type="checkbox"/>	Disabled
MaxTransferTime	MAXIMUM TRANSFER TIME	<input type="checkbox"/>	15 1-30 SEC
Transfer Fail	TRANSFER FAIL	<input type="checkbox"/>	ForceTransfer
ManualReturn	MANUAL RETURN	<input type="checkbox"/>	Disabled
UtilReturnDelay	UTILITY RETURN DELAY	<input type="checkbox"/>	2.0 0.0-50.0 MIN
CLOSED TRANSITION LOGIC			
MaxSyncTime	MAXIMUM SYNCHRONIZING TIME	<input type="checkbox"/>	1 0-10 MIN
MaxPSDOpenTime	MAXIMUM POWER SWITCHING DEVICE OPEN TIME	<input type="checkbox"/>	1 1-3 SEC
PROGRAMMABLE OUTPUTS LOGIC			
ProgrammableOutput	PROGRAMMABLE OUTPUT	<input type="checkbox"/>	LoadOnGen
VOLTAGE CALIBRATION			





**TSC 800
MICROPROCESSOR TRANSFER SWITCH CONTROLLER
CALIBRATION DATA**

WORK ORDER	W-123456	REV.:	0	FIRMWARE VERSION:	TSC v2.0 ATS
		REV. DATE:	04/12/14		
		CUSTOMER:		DEFAULT PROGRAM:	800_V20_M24
INITIATED BY:		PROJECT NAME:			
DATE:	04/12/14	NOTES:			

CONTROLLER S/N: GENC_W-123456
CALIBRATED BY:
CALIBRATION DATE: 04/12/15

UtilLLZero	UTILITY LINE TO LINE ZERO	127	0-255
UtilLLSpan	UTILITY LINE TO LINE SPAN	127	0-255
UtilL1Zero	UTILITY LINE1 TO NEUTRAL ZERO	127	0-255
UtilL1Span	UTILITY LINE1 TO NEUTRAL SPAN	127	0-255
UtilL2Zero	UTILITY LINE2 TO NEUTRAL ZERO	127	0-255
UtilL2Span	UTILITY LINE2 TO NEUTRAL SPAN	127	0-255
GenLLZero	GENERATOR LINE TO LINE ZERO	127	0-255
GenLLSpan	GENERATOR LINE TO LINE SPAN	127	0-255
GenL1Zero	GENERATOR LINE1 TO NEUTRAL ZERO	127	0-255
GenL1Span	GENERATOR LINE1 TO NEUTRAL SPAN	127	0-255
GenL2Zero	GENERATOR LINE2 TO NEUTRAL ZERO	127	0-255
GenL2Span	GENERATOR LINE2 TO NEUTRAL SPAN	127	0-255
LoadLLZero	LOAD LINE TO LINE ZERO	127	0-255
LoadLLSpan	LOAD LINE TO LINE SPAN	127	0-255
LoadL1Zero	LOAD LINE1 TO NEUTRAL ZERO	127	0-255
LoadL1Span	LOAD LINE1 TO NEUTRAL SPAN	127	0-255
LoadL2Zero	LOAD LINE2 TO NEUTRAL ZERO	127	0-255
LoadL2Span	LOAD LINE2 TO NEUTRAL SPAN	127	0-255

9. TSC 800 TYPICAL CONNECTION DIAGRAM

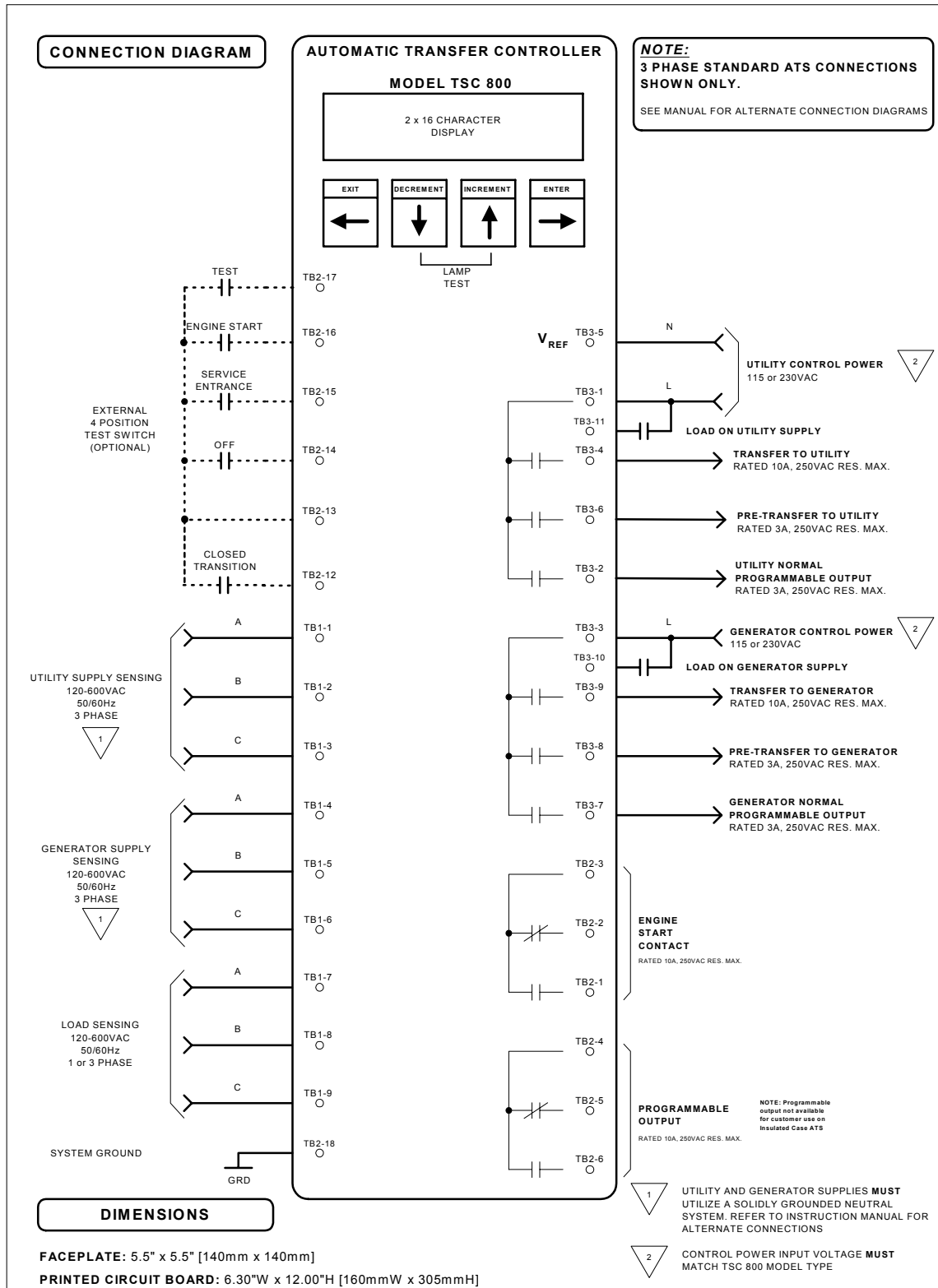

FULL FILENAME

DRAWING1

REVISED 04-12-15 11:00 AM

10. TSC 800 SPECIFICATIONS

- POWER SUPPLY:
 - 115 or 230VAC nominal (+10% -30%)
 - 50/60Hz
 - 100ma nominal (no external load connected)

- SOURCE VOLTAGE SENSING:
 - Direct 120-600VAC nominal, single or three phase
 - 50/60Hz
 - +/- 0.5% accuracy of setting @ 25°C

- OPERATING TEMPERATURE:
 - 15°C to +50°C

- OUTPUT CONTACTS (Form C, 10A, 120/250VAC resistive)
 - Engine start
 - Programmable function (not available with dual source system logic or insulated case transfer switches)

- OUTPUT SIGNALS (120/250VAC resistive load)
 - Transfer to utility 10A
 - Transfer to generator 10A
 - Pre/post-transfer to utility 3A
 - Pre/post-transfer to generator 3A
 - Load on utility 3A
 - Load on generator 3A

11. TROUBLESHOOTING

A number of problems can cause the TSC 800 controller not to function properly. Refer to the following list of typical problems. Consult the factory for any detailed information or for any problems not listed.

CAUTION!!!

Before opening the enclosure to perform any service task, it is imperative to isolate the transfer switch from any possible source of power. Failure to do so may result in serious personal injury or death due to electrical shock.

Service procedures must be undertaken by qualified personnel only!

Symptom

* **Will not re-transfer to utility source upon restoration**

Possible Causes

- A test mode has been activated (check TSC 800 status LCD display)
- Utility voltage or frequency is outside the pre-programmed limits (check utility source for adequate voltage & frequency)
- A loose control connection
- Faulty contactor auxiliary contact
- Defective utility contactor coil
- Defective TSC 800 controller (verify output signals with circuit board mounted diagnostic LED's)
- TSC 800 has "Transfer Fail" alarm activated (if programmed as "Force Transfer). Determine cause of alarm and rectify before TSC 800 is reset
- Bad limit or auxiliary switch N/C contact or loose wire termination between the controller and the limit switch
- TSC 800 programmed for manual retransfer. Press Lamp test to initiate retransfer to Utility Source.
- A phase unbalance condition was detected on the Utility supply while on load. The condition may not be readily noticeable with no load on the source. Confirm voltage unbalance condition by viewing alarm state on TSC 800 LCD. In this state the load is locked to the generator until the TSC 800 is reset.

- **Will not transfer to generator source upon failure of utility source**

- Generator set not producing enough voltage/frequency or local generator output circuit breaker open (outside programmed limits of TSC 800)
- Warm up time delay function has not timed out yet (verify TSC 800 timer setting, 0 -3000 seconds programmable)
- A loose control wire connection
- Faulty contactor auxiliary contact
- Defective generator contactor coil
- Defective TSC 800 controller (verify output signals with circuit board mounted diagnostic LED's) and AC voltage at appropriate TSC 800 controller terminal
- TSC 800 has "Transfer Fail" alarm activated (if programmed as "Force Transfer). Determine cause of alarm and rectify before TSC 800 is reset
- Bad limit or auxiliary switch N/C contact or loose wire termination between the controller and the limit switch
- A phase unbalance condition was detected on the Generator supply prior to or while on load. The condition

Symptom

Possible Causes

Will not transfer to generator source upon failure of utility source (cont'd)

- **Transfer to generator source without a power failure in the utility source**

* **Generator does not start up or stop when it should**

* **No time delay when there should be**

- **Power is not available at the ATS load terminals but the utility or generator power switching device appears to be closed to a live source**

* **TSC 800 Display is Blank**

may not be readily noticeable with no load on the source. .
Confirm voltage unbalance condition by viewing alarm state on TSC 800 LCD. In this state the load is locked to the utility source until the TSC 800 is reset

- Transfer switch motor brake assembly will not release. Possible interference with field installed wiring. Only possible on 100 through 250 Amp ATS's with exposed mechanical brake.

- A test mode has been activated (check TSC 800 status LCD display, can be via internal or external test inputs)

- Defective TSC 800 controller (verify output signals with circuit board mounted diagnostic LED's)

- Loose or broken wire to the utility voltage sensing terminals on the TSC 800 controller

- Failed voltage sensing circuit on TSC 800, repair or replace controller.

- Utility supply voltage is slightly above or below voltage sensing set points. Compare TSC 800 program voltage set points with actual utility voltage displayed on the controller

- Incorrect voltage calibration providing incorrect readings for Utility Sensing and being interpreted as being out of limit.

- A transfer fail condition on the Utility PSD or limit switch has occurred, review LCD for alarm condition, press lamp test to reset.

- A phase unbalance condition was detected on the Utility supply while on load. The condition may not be readily noticeable with no load on the source. Confirm voltage unbalance condition by viewing alarm state on TSC 800 LCD. Press lamp test to reset.

- Verify remote engine control panel is set for automatic mode and no shutdown faults present.

- Verify remote engine start interconnect wiring properly terminated (not open circuit).

- Engine Start relay on TSC 800 has failed or been damaged due to excessive current.

- TSC 800 non-functional. Confirm the Watch Dog LED on rear of circuit board to be flashing (processor healthy) and the Engine Start LED is on confirming the start request.

- Verify time delay function in the TSC 800 program setting as per programming sheets as supplied with the transfer switch

- The power switching device's trip unit (service entrance style only) has tripped on a fault on the system and TSC 800 "Transfer Fail" is programmed as "Disabled or Halt Transfer". Correct the fault, and manually reset the power-switching device in the transfer switch by moving it off and then on again with the manual operating handle.

- Display in Sleep Mode. Press any keypad to re-energize the display.

- There is no power to the controller. Confirm power to the

Symptom

Possible Causes

TSC 800 Display is Blank (cont'd)

controller from available supplies. Possible external controller Power Transformer failed (PT1 & 2)or controller mounted transformer or internal power supply failed (one or both sources).

- Isolation Plug is pulled. Confirm correct voltage configuration and/or levels prior to installing the Isolation Plug.
- Utility power is failed and generator running but its local breaker is open.

* **Transfer Switch Cycles between sources**

- Limit Switch is not being fully actuated to break the motor circuit during transfer. Limit switch adjustment incorrect (Limit Switch Struck Late or not at all on 100A-1200A molded case switch style ATS).
- TSC 800 generator under voltage and/or under frequency time delays set to short. Time delays are exceeded on load application causing recycling to Utility supply (happens only during an on load test and utility available).

* **Transfer Switch controller indicates the mechanism has made position but does not conduct to the load bus and the PSD is not tripped**

- Limit switch adjusted to close to yoke arm causing the ATS mechanism to stop before PSD closes (Limit Switch Struck Early on 100A-1200A molded case switch style ATS).

* **Less than programmed Neutral Delay Time (NDT) or none at all administered during transfer between powered sources.**

- Neutral Delay Bypass feature enabled. Effectively cancels NDT if not required (canceled if load bus voltage for all phases drops below 20% of nominal system voltage). Normal Operation.
- Transfer Switch incorporates a Bypass configuration (currently is bypassing the ATS mechanism) and the test cable connected. No neutral positioning will be detected and no NDT applied as a result (normal condition).
- High residual voltage from the connected loads (neutral position can not be determined). Contact Thomson Technology for possible corrective solutions.

* **Engine runs for no apparent reason**

- Verify the TSC 800 has not been set for a manual or auto off load test operation. If yes, select "Auto" ("None" in firmware versions 1.7 and earlier).
- Verify the TSC 800 engine start LED is lit on the rear of the controller. If not lit isolate one of the remote start wires to confirm the start is from the TSC 800 (contact closes to start, open wire should cause generator to stop). Engine start relay coil on TSC 800 failed (drops to issue start, energized to inhibit start).
- Local Generator Engine controller has built in cool down function or test features separate from the TSC 800.
- Local generator controls are in Manual Run.

* **Oscillating/unstable voltage readings displayed for one or more sources when measured voltage with an independent meter confirms stable voltage**

- System neutral conductor has not been solidly bonded to ground for one or more of the sources or a 3-phase 3-wire system has been applied to an ATS designed for a 3-phase 4-wire configuration. Isolation transformers will need to be added to create the ground reference to correct the problem. Contact Thomson Technology for corrective

Symptom

Possible Causes

Oscillating/unstable voltage readings displayed for one or more sources when measured voltage with an independent meter confirms stable voltage (cont'd)

* **TSC 800 Displays voltage values well in excess of actual**

solutions.

- Defective TSC 800 controller. Contact Thomson Technology for replacement.

- The wrong voltage sensing ratio has been programmed
- Secondary power transformers used for sensing are installed improperly. Polarities of PT's were not observed during installation/replacement. Contact the factory for assistance.
- Defective TSC 800 controller. Contact Thomson Technology for replacement.

12. REPLACEMENT PARTS

Replacement parts are available for the TSC 800 controller as follows:

TSC 800 Controller Board	P/N 002661
TSC 800 115V Selector Plug	P/N 002633 (2 required)
TSC 800 230V Selector Plug	P/N 002634 (2 required)
TSC 800 Lexan Faceplate	P/N 001599 (Standard 5.5"X5.5" Lexan)
TSC 800 Rear Cover	P/N 001073
TSC 800 LCD	P/N 000559
TSC 800 LCD connector	P/N 000264
TSC 800 LCD Gasket	P/N 001074

When ordering replacement parts please provide the following information:

1. Transfer Switch Model code (e.g. TS 873AA0200AS)
2. Transfer Switch Serial Number (e.g. W-022345)

The above information can be found on the transfer switch rating plate located on the outside of the ATS door.

For other parts not listed, please contact Thomson Technology.

NOTE

There are no user serviceable/replaceable components located on the TSC 800 printed circuit board. If the TSC 800 controller is deemed to be defective it must be returned to the Thomson Technology Factory for repair or replacement. Please refer to Section 13 for further detailed on product return procedures required.

13. PRODUCT RETURN POLICY

Thomson Technology uses a Return Material Authorization (RMA) process. Please complete the [Return Authorization Request Form](#) (available on our web page) for return of goods, warranty replacement/repair of defective parts, or credit consideration and fax to the appropriate department.

Returns only: Sales Fax (604) 888-5606

Warranty replacement/Warranty Repair: Service Fax (604) 888-3370.

Upon receipt of your request, Thomson Technology will confirm with a copy of our Order Acknowledgement via fax advising the RMA number which should be used to tag the defective controller prior to shipment.

