



TSC 80

TRANSFER SWITCH CONTROLLER

**INSTALLATION, OPERATING &
SERVICE MANUAL**

Software Version 1.1

PM063 REV 1 05/05/11

TABLE OF CONTENTS

1.	INTRODUCTION	1
1.1.	PRODUCT REVISION HISTORY	1
1.2.	GENERAL INFORMATION	1
1.3.	SERVICE DISPLAY MODULE (SDM)	2
1.4.	NOTES TO TRANSFER SWITCH INSTALLER	2
1.4.1.	SYSTEM VOLTAGE	2
1.4.2.	SYSTEM PHASING-HIGH LEG DELTA SYSTEMS	3
1.4.3.	REMOTE START CONTACT FIELD WIRING	4
1.4.4.	DIELECTRIC TESTING	5
2.	DESCRIPTION	5
2.1.	LEXAN FACEPLATE	6
2.2.	PRINTED CIRCUIT BOARD	7
2.2.1.	VOLTAGE SELECTION	7
2.2.2.	TERMINAL BLOCKS	8
2.2.3.	DIAGNOSTIC LED'S	8
2.2.4.	ADJUSTMENT POTENTIOMETERS	9
2.2.5.	CONFIGURATION JUMPERS	9
2.3.	CONTROLLER FEATURES	9
2.4.	APPLICATION INFORMATION	10
2.4.1.	AC VOLTAGE SENSING INPUT	10
2.4.2.	AC CONTROL POWER INPUT	12
2.4.3.	OUTPUTS	12
3.	OPERATING INSTRUCTIONS	12
3.1.	AUTOMATIC SEQUENCE OF OPERATION	12
3.1.1.	NORMAL OPERATION	12
3.1.2.	ABNORMAL OPERATION	13
3.2.	TEST MODES	16
3.2.1.	UTILITY POWER FAIL SIMULATION (LOAD TEST)	16
3.2.2.	AUTOMATIC PLANT EXERCISE LOAD TEST	16
3.2.3.	FOUR FUNCTION REMOTE TEST (FTS4 OPTION)	17
3.2.4.	REMOTE TEST	18
3.3.	TRANSFER FAIL FAULT RESET	18
3.4.	LAMP TEST	19
3.5.	TIMER BYPASS	19

4.	CONFIGURATION INSTRUCTIONS	19
4.1.	CONFIGURATION JUMPERS	19
4.1.1.	SYSTEM VOLTAGE	20
4.1.2.	SYSTEM FREQUENCY	22
4.1.3.	SYSTEM PHASES	22
4.1.4.	GEN EXERCISE LOAD TEST MODE (NO XFER)	23
4.1.5.	SECURE	23
4.2.	ADJUSTMENT POTENTIOMETERS	24
4.2.1.	UTILITY UNDER VOLTAGE SETPOINT	24
4.2.2.	GENERATOR UNDERVOLTAGE SETPOINT	25
4.2.3.	GENERATOR UNDER FREQUENCY SETPOINT	26
4.2.4.	ENGINE START DELAY	27
4.2.5.	ENGINE WARMUP DELAY	27
4.2.6.	ENGINE COOLDOWN DELAY	27
4.2.7.	UTILITY RETURN DELAY	27
4.2.8.	NEUTRAL DELAY	28
5.	TSC 80 TYPICAL CONNECTION DIAGRAM	29
6.	TSC 80 SPECIFICATIONS	30
7.	TROUBLESHOOTING	31
8.	REPLACEMENT PARTS	32
9.	PRODUCT RETURN POLICY	33
10.	NOTES	34

1. INTRODUCTION

1.1. PRODUCT REVISION HISTORY

The following information provides an historical summary of changes made to this product since the original release.

Software Version

1.0 04/11/19	Original version
1.1 05/05/10	Software updated to incorporate the following: <ul style="list-style-type: none"> <input type="checkbox"/> Revise potentiometer control directions to match revised printed circuit board silkscreen text. <input type="checkbox"/> Change operation associated to “secure” configuration jumper. Enable remote load test to be activated if secure jumper is ON.

Operating & Service Manual Version

Rev 0 04/11/19	Original release
Rev 1 05/05/10	The following changes have been incorporated: <ul style="list-style-type: none"> <input type="checkbox"/> Add changes for revised TSC 80 Software version 1.1. <input type="checkbox"/> Add new Environmental Section <input type="checkbox"/> Miscellaneous changes

Contact Thomson Technology, to obtain applicable instruction manuals. Soft copy of most current version is available at www.thomsontechnology.com.

1.2. GENERAL INFORMATION

NOTE:

Installations should be done in accordance with all applicable electrical regulation codes as required.

The following information is provided for general information only pertaining to TSC 80 transfer switch controllers installed in a Thomson Technology Automatic Transfer Switch as applied in a typical site installation. For specific site installation information, consult Thomson Technology as required.

**CAUTION**

contents subject to damage by
STATIC ELECTRICITY

This equipment contains static-sensitive parts. Please observe the following anti-static precautions at all times when handling this equipment. Failure to observe these precautions may cause equipment failure and/or damage.

- Discharge body static charge before handling the equipment (contact a grounded surface and maintain contact while handling the equipment, a grounded wrist strap can/should also be utilized).
- Do not touch any components on the printed circuit board with your hands or any other conductive equipment.
- Do not place the equipment on or near materials such as Styrofoam, plastic and vinyl. Place the equipment on grounded surfaces and only use an anti-static bag for transporting the equipment.

1.3. SERVICE DISPLAY MODULE (SDM)

An optional hand held, plug-in Service Display Module (SDM) is available for the TSC 80 Transfer Controller. The SDM module provides an LCD screen to display additional detailed information on the operation and settings of the TSC 80 controller for simplified servicing/trouble shooting procedures. For detailed information, refer to the separate SDM module instruction manual (PM065).

1.4. NOTES TO TRANSFER SWITCH INSTALLER**1.4.1. SYSTEM VOLTAGE**

If the transfer switch has programmable/multi-tap system voltage capability (refer to electrical schematic), confirm the transfer switch has been configured for the correct system voltage. If the transfer switch requires reconfiguring, the TSC 80 controller will require reconfiguration as well.

WARNING

Failure to confirm and match transfer switch voltage with the system voltage could cause serious equipment damage.

1.4.2. SYSTEM PHASING-HIGH LEG DELTA SYSTEMS

When the transfer switch is connected to 3 phase 4 wire delta systems, the “High” leg (Phase B, colored Orange), must be connected to Phase B of the Utility and/or Generator supply. This will ensure the ATS control power which is internally connected between phase A and neutral is maintained at 120VAC. Refer to figure below for further details.

WARNING

Failure to match correct system phasing will result in serious damage to the TSC 80 controller.

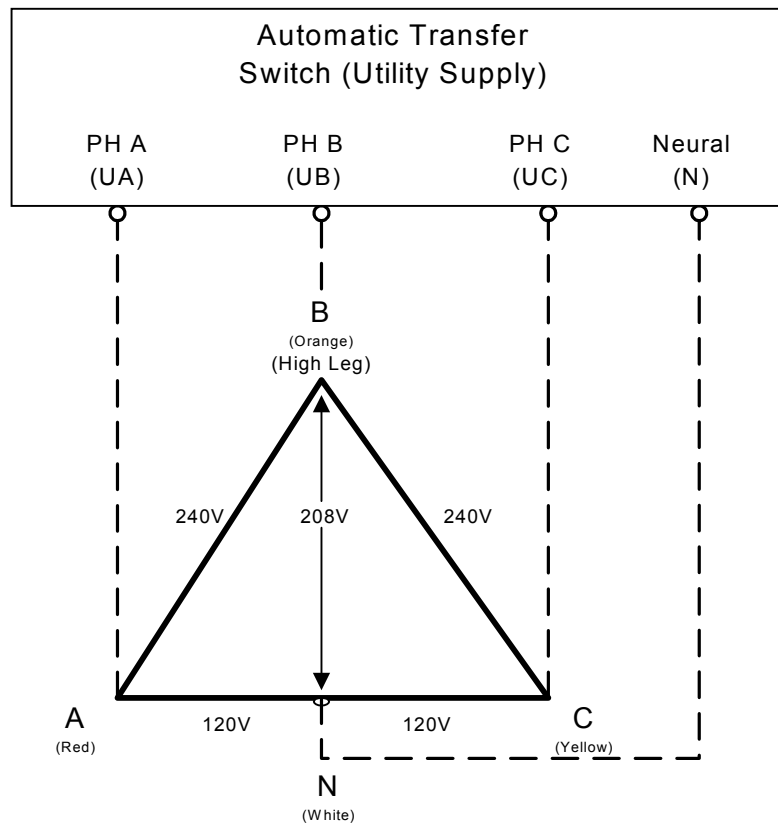

CAUTION!!!

All installation and/or service work performed must be done by qualified personnel only. Failure to do so may cause personal injury or death.

1.4.3. REMOTE START CONTACT FIELD WIRING

As a minimum, the remote engine start control field wiring shall conform to the local regulatory authority on electrical installations. Field wiring of a remote start contact from a transfer switch to a control panel should conform to the following guidelines to avoid possible controller malfunction and/or damage.

1.4.3.1. Minimum #14 AWG (2.5mm²) wire size shall be used for distances up to 100ft (30m)¹). For distances exceeding 100 ft. (30m) consult Thomson Technology.

1.4.3.2. Remote start contact wires should be run in a separate conduit.

1.4.3.3. Avoid wiring near AC power cables to prevent pick-up of induced voltages.

1.4.3.4. An interposing relay may be required if field-wiring distance is excessively long (i.e. greater than 100 feet (30m)) and/or if a remote contact has a resistance of greater than 5.0 ohms.

1.4.3.5. The remote start contact must be voltage free (i.e. dry contact). The use of a “powered” contact will damage the transfer controller.

1.4.4. DIELECTRIC TESTING

Do not perform any high voltage dielectric testing on the transfer switch with the TSC 80 controller connected into the circuit as serious damage will occur to the controller. All AC control fuses and control circuit isolation plugs connected to the TSC 80 must be removed if high voltage dielectric testing is performed on the transfer switch.

2. DESCRIPTION

The TSC 80 controller utilizes microprocessor-based design technology, which provides high accuracy for all voltage sensing and timing functions. The **TSC 80** is factory configured to control all the operational functions and display features of the automatic transfer switch.

The TSC 80 controller consists of two parts; a Lexan faceplate, which is mounted externally on the transfer switch door, and a printed circuit board (PCB), which is mounted inside the transfer switch on the enclosure door.

2.1. LEXAN FACEPLATE

The Lexan faceplate is shown as in FIGURE 1. The Lexan pushbuttons and LED lights are connected to the main PCB via plug-in ribbon cable. The main features of the Lexan faceplate are described as follows with reference to FIGURE 1.

- ① Utility Supply Available LED light
- ② Load on Utility supply LED light
- ③ Load on Generator supply LED light
- ④ Generator Supply Available LED light
- ⑤ ATS Load Bus Energized LED light
- ⑥ Utility Power Fail Test Mode Pushbutton & LED light
- ⑦ Generator Exercise Mode Pushbutton & LED light

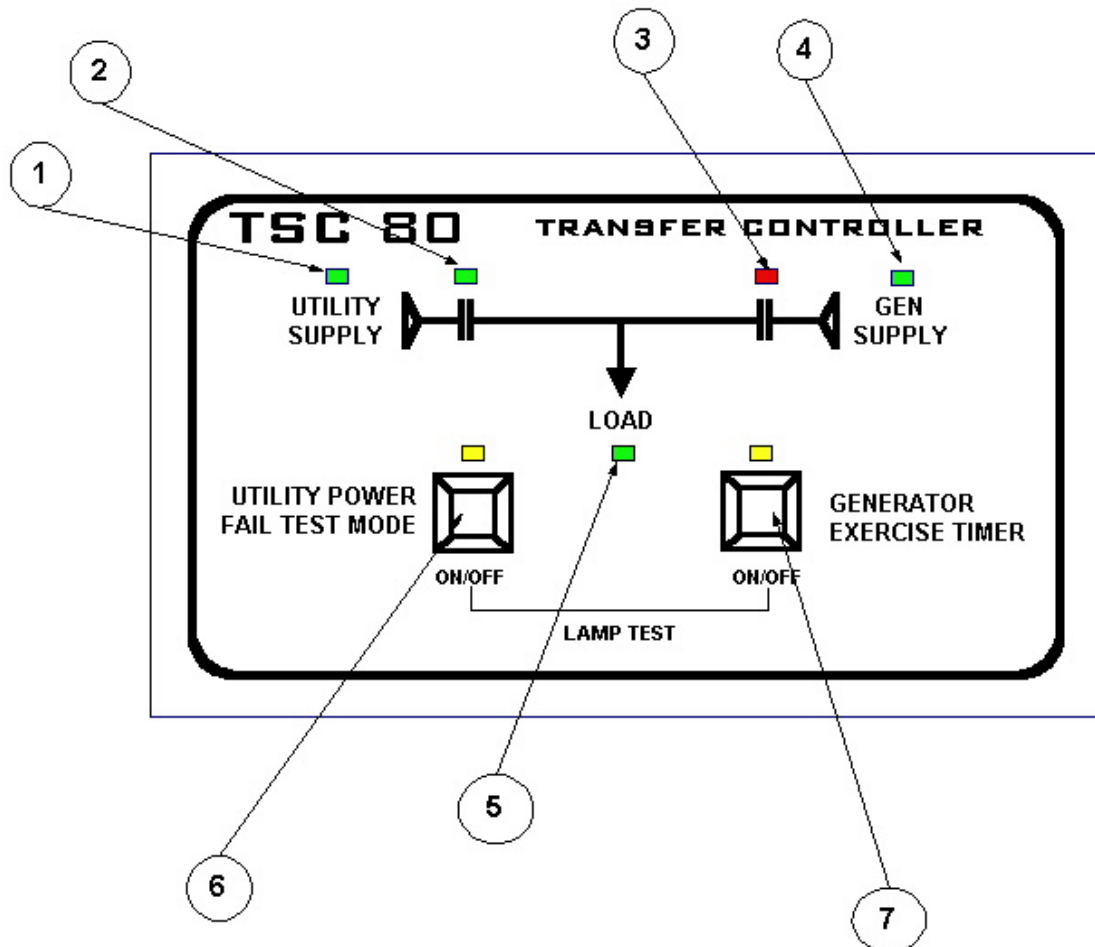

FIGURE 1

2.2. PRINTED CIRCUIT BOARD

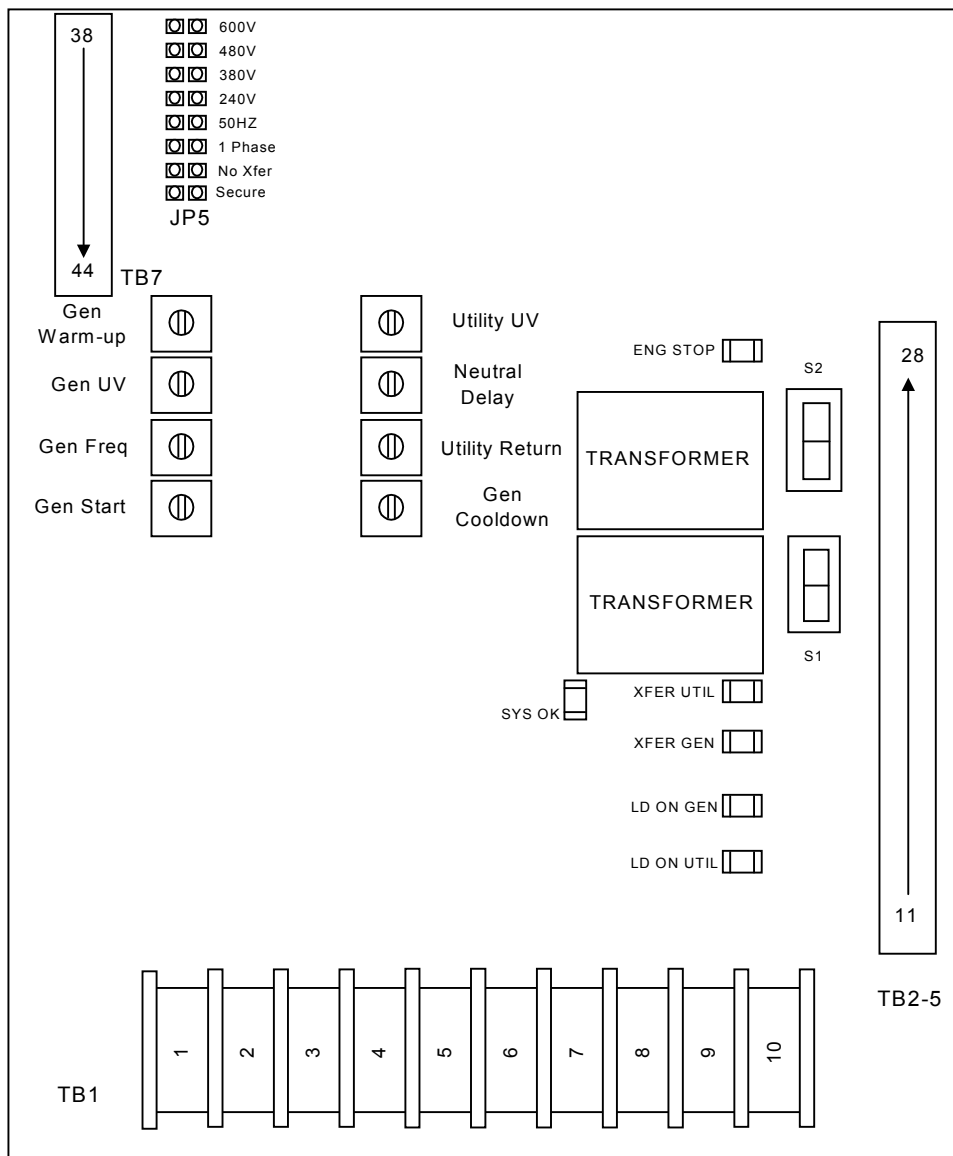

FIGURE 2

The printed circuit board (PCB) is shown in FIGURE 2. The PCB contains the following user interface items:

2.2.1. VOLTAGE SELECTION

The voltage selection is made via two selector switches, which are located on the PCB and are identified as S1 and S2.

The TSC 80 is factory configured for specific power supply voltage inputs according to the ATS Application.

WARNING

The setting of Switches S1 & S2 are factory set to match system application voltage. Do not change the position of selector switch S1 or S2 while the TSC 80 is energized. Contact the Thomson Technology Factory for further information. Failure to do so may cause equipment failure, personnel injury and/or death.

2.2.2. TERMINAL BLOCKS

Terminal blocks are located on the PCB as follows:

TB1 high voltage sensing terminal block (120-600VAC).

WARNING

Voltage sensing circuits are capable of lethal voltages while energized. Standard safety procedures should be followed and be performed by qualified personnel only. Failure to do so may cause personnel injury and/or death.

TB2-6 transfer control terminal block for 115/230V control power and input/output circuits.

TB7 low voltage (5Vdc) control inputs.

2.2.3. DIAGNOSTIC LED'S

The TSC 80 controller provides diagnostic LED lights, which are mounted on the printed circuit board as per FIGURE 2. Their functions are described as follows:

SYS OK This LED flashes on and off at irregular intervals, which indicates the microprocessor is functioning normally.

TRANSFER TO UTILITY This LED is illuminated whenever the TSC 80 is initiating a signal to transfer to the Utility supply.

TRANSFER TO GEN This LED is illuminated whenever the TSC 80 is initiating a signal to transfer to the Generator supply.

ENGINE STOP This LED is illuminated whenever the TSC 80 is initiating an Engine STOP signal.

2.2.4. ADJUSTMENT POTENTIOMETERS

The TSC 80 controller provides eight adjustment potentiometers, which are mounted on the printed circuit board as per FIGURE 2. They are used for adjustment of all time delays, voltage and frequency setpoints. All potentiometers will be set to factory default values. Refer to *SECTION 4 (CONFIGURATION INSTRUCTIONS)* for further information.

2.2.5. CONFIGURATION JUMPERS

The TSC 80 controller provides eight Configuration Jumpers, which are mounted on the printed circuit board as per FIGURE 2. They are used for configuration of main system operating parameters such as voltage, frequency, phases. Refer to *SECTION 4 (CONFIGURATION INSTRUCTIONS)* for further information.

2.3. CONTROLLER FEATURES

The Thomson Technology TSC 80 Transfer Switch Controller utilizes the latest advancements in microprocessor technology, printed circuit board assembly and software for control of automatic transfer switches. The TSC 80 is the second generation of microprocessor-based transfer switch controllers from Thomson Technology, and reflects over 30 years of transfer switch control experience. The TSC 80 is factory configured to monitor, display and control all operational functions of the automatic transfer switch. All voltage sensors and timers are fully user adjustable utilizing potentiometers, which requires no software configuration. The microprocessor design provides high accuracy for all voltage sensing and timing functions as well as providing many standard features.

- ❑ Utility AC voltage sensing (true RMS) – 120-600V single phase or 3 phase
- ❑ Generator AC voltage sensing (true RMS) – 120-600V single phase or 3 phase
- ❑ Generator AC frequency sensing
- ❑ Utility under voltage control setpoint 70 - 95% (adjustable)
- ❑ Generator under voltage control setpoint 70 - 95% (adjustable)
- ❑ Generator under frequency control setpoint 70 - 90% (adjustable)
- ❑ Engine warmup timer 0-60 sec. (adjustable)
- ❑ Utility return timer 0-30 min. (adjustable)
- ❑ Engine start timer 0-60 sec. (adjustable)
- ❑ Engine cooldown timer 0-30 min. (adjustable)
- ❑ Neutral position delay timer 0-60 sec. (adjustable)
- ❑ Local utility power fail simulation test pushbutton & LED, door mounted
- ❑ Remote utility power fail simulation test pushbutton input (via terminal block)

- ❑ Load on utility supply & load on generator supply LED's, door mounted
- ❑ Utility and generator source available LED's, door mounted
- ❑ Weekly plant exercise timer (30 min. on load) manually initiated
- ❑ Local plant exercise initiate pushbutton & LED, door mounted
- ❑ Engine start contact (10A, 120/240VAC resistive max.)
- ❑ Load on utility auxiliary contact (Qty 1 only, 10A, 120/240VAC, Form C)
- ❑ Load on generator auxiliary contact (Qty 1 only, 10A, 120/240VAC, Form C)
- ❑ Transfer fail/forced transfer logic
- ❑ Automatic force transfer to alternate supply should load voltage become de-energized
- ❑ 50 or 60Hz capable (115V or 230V control power)
- ❑ Remote Load Test/Peak Shave Input

2.4. APPLICATION INFORMATION

2.4.1. AC VOLTAGE SENSING INPUT

The TSC 80 can accept direct AC voltage sensing inputs on the generator and utility supplies from 120-600VAC (nominal). **Note:** Direct input voltage sensing can only be used when the system utilizes a 3 phase, 4 wire distribution system which has the neutral conductor *solidly* grounded. For 3 phase, 3 wire systems (i.e. no neutral) or high voltage systems, potential transformers must be used. Refer to FIGURE 3 for voltage sensing connections.

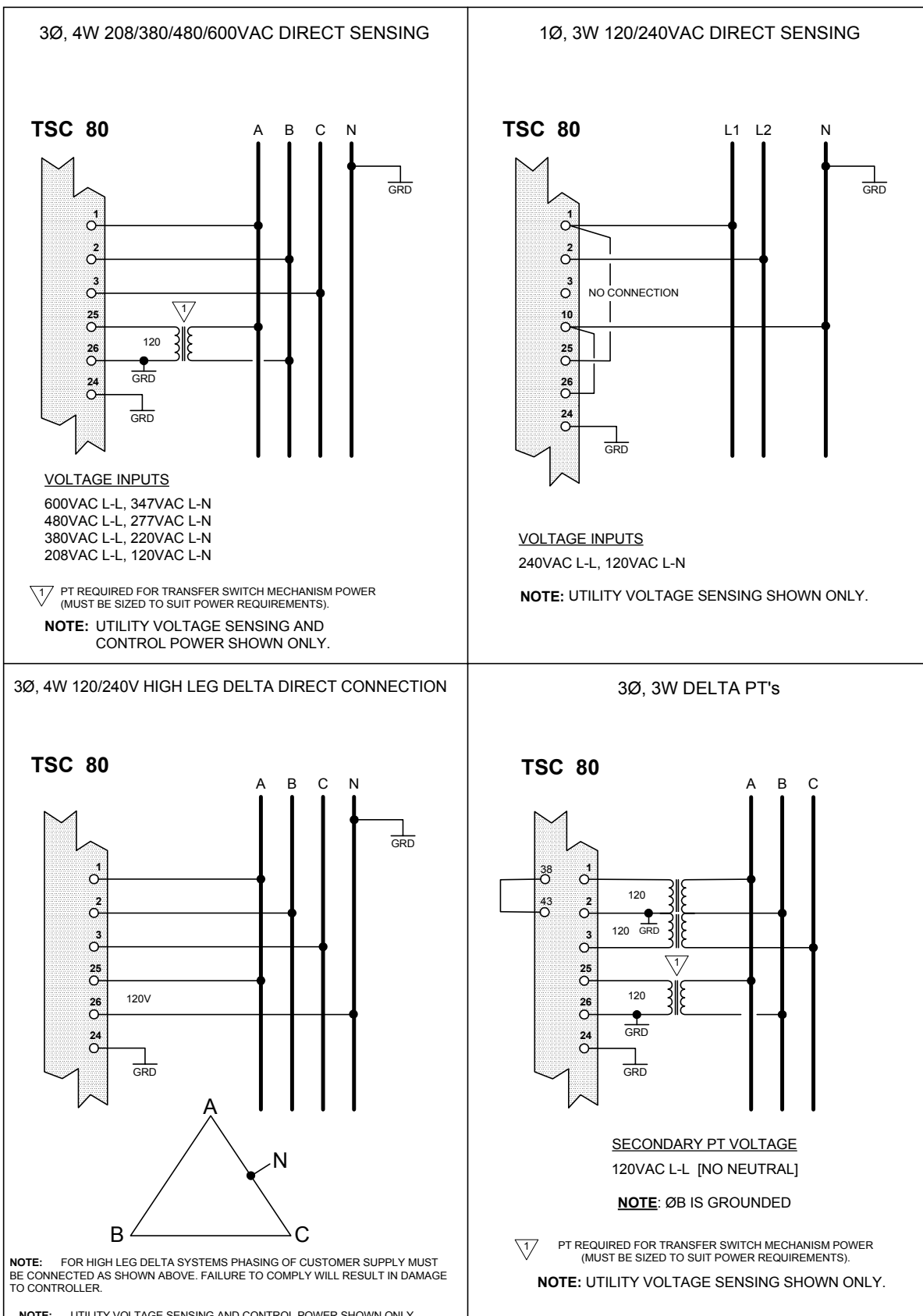

FIGURE 3

2.4.2. AC CONTROL POWER INPUT

The TSC 80 is factory supplied for either 115VAC or 230VAC (nominal) control power input voltage. Independent AC control power is required from both utility and generator supplies. AC control power is utilized for internal TSC 80 control circuits and external control device loads. The TSC 80 requires approximately 6 VA power for internal control circuits. The maximum external load is limited by output contact ratings (i.e. 10A resistive, 120VAC). Total AC control power requirements for each supply must be determined by adding both internal and external load requirements.

2.4.3. OUTPUTS

The TSC 80 provides the following types of output circuits:

Engine Start Contact	Isolated Form B contact (10A, 120VAC Resistive)
Load on Utility	Isolated Form C contact (10A, 120VAC/250VAC Resistive)
Load on Generator	Isolated Form C contact (10A, 120VAC/250VAC Resistive)
Transfer to Utility Output	120VAC ¹ , 10A (Resistive) powered output contact
Transfer to Generator Output	120VAC ¹ , 10A (Resistive) powered output contact

¹ **Note:** Output voltage is dependent upon AC control power input voltage (i.e. 120VAC or 230VAC nominal).

Interposing relays are required between the TSC 80 outputs and the end device if loads exceed the output current rating.

3. OPERATING INSTRUCTIONS

To operate the TSC 80 controller and associated transfer switch using the front faceplate pushbuttons, refer to the following detailed operating instruction sub-section descriptions.

3.1. AUTOMATIC SEQUENCE OF OPERATION

3.1.1. NORMAL OPERATION

Under normal operating conditions, the transfer switch operates automatically during a failure and restoration of utility power and does not require operator intervention.

When utility supply voltage drops below a preset nominal value (70 - 95% of rated adjustable) on any phase, an engine start delay circuit will be initiated and the transfer to utility supply signal will be removed (i.e. contact opening). Following expiry of the engine start delay period (0 - 60 sec. adjustable) an engine start signal (contact closure) will be given.

Once the engine starts, the transfer switch controller will monitor the generators voltage and frequency levels. Once the generator voltage and frequency rises above preset values (70 - 95% nominal adjustable) the Engine Warm-up timer will be initiated. Once the Engine Warm-up timer expires (0-60 sec. Adjustable), the transfer to generator supply signal (contact closure) will be given to the transfer switch mechanism. The load will then transfer from the utility supply to the generator supply via motor driven mechanism.

The generator will continue to supply the load until the utility supply has returned and the retransfer sequence is completed as follows: When the utility supply voltage is restored to above the present values (70 - 95% of rated adjustable) on all phases, a transfer return delay circuit will be initiated. Following expiry of the utility transfer return timer (0 - 30 min. adjustable), the transfer to generator supply signal will be removed (contact opening), then the transfer to utility supply signal (contact closure) will be given to the transfer switch mechanism. The load will then be transferred from the generator supply back to the utility supply. During the utility re-transfer sequence a neutral position delay circuit will cause the transfer mechanism to pause in the "neutral position (i.e. with both transfer power switching devices open) for the duration of the neutral delay timer (0-30 seconds adjustable) setting. Once the time delay expires, the re-transfer sequence will be completed.

An engine cooldown timer circuit will be initiated once the load is transferred from the generator supply. Following expiry of the cooldown delay period (0 - 30 min. adjustable) the engine start signal will be removed (contact opening) to initiate stopping of the generator set.

3.1.2. ABNORMAL OPERATION

3.1.2.1. TEST CONDITION

A test pushbutton on the transfer switch shall signal a simulated utility power fail signal to the transfer switch controller. The transfer switch shall operate as per a normal utility power fail condition. The neutral delay circuit logic will be active during transfer to and from the generator supply (i.e. when both sources of power are available).

The transfer switch shall remain on generator supply until the test mode is terminated. It will then retransfer back to the utility supply following the transfer

return timer and then continue to operate the generator set for its cooldown period then stop.

3.1.2.2.GENERATOR FAILURE ON LOAD

Should the generator set fail while on load, the transfer switch shall retransfer the load back to the utility supply if within nominal limits. The utility return timer will be bypassed in this condition.

NOTE

This operating condition shall apply to a normal utility failure as well as any test condition.

3.1.2.3.TRANSFER SWITCH FAIL ALARM LOGIC

The TSC 80 controller contains logic to detect a transfer mechanism failure. Should a failure be detected, a forced transfer to the alternate supply will be initiated. Detailed logic operation is as follows:

NOTE

The “TRANSFER SWITCH FAIL” feature can be disabled by activating the “Service Entrance” Mode by jumpering terminal numbers 38 & 42. The TSC 80 controller will not verify that the transfer mechanism has operated correctly.

3.1.2.4.TRANSFER FAIL DETECTION-NORMAL STEADY STATE CONDITION (NON-TRANSFERRING)

- i. Limit Switch Failure (i.e. open contact) - Transfer Fail Alarm is initiated (Load on Source Flashing LED) after 9 second delay, and then a forced transfer to the alternate source is initiated. Re-transfer back to the original source will not occur until the Transfer Fail alarm condition is reset. Refer to item 3.3 for Transfer Fail Fault Reset details.
- ii. Loss of Load Voltage (<80VAC) (i.e. Power switching device Tripped Condition) - Transfer Fail Alarm is initiated (Load Source Flashing LED) after 5 second delay, then a forced transfer to the alternate source is initiated. Re-transfer back to the original source will not occur until the Transfer Fail alarm condition is reset. Refer to item 3.3 for Transfer Fail Fault Reset details.
- iii. Limit Switch Failure & Loss of Load Voltage <80VAC - Transfer Fail Alarm is initiated (Load Source Flashing LED) after **11** second delay, then a

forced transfer to the alternate source is initiated. Re-transfer back to the original source will not occur until the Transfer Fail alarm condition is reset. Refer to item 3.3 for Transfer Fail Fault Reset details.

3.1.2.5. TRANSFER FAIL DETECTION - TRANSFERRING CONDITION

Transfer Source to Neutral – “Find Neutral/Source Timer” (10 seconds-fixed) starts timing as soon as a transfer to the alternate source is initiated. During this period the ATS motor is energized and moves the mechanism from the original source to neutral. The power to the motor will be de-energized when either the “Find Neutral/Source Timer” times out or the load voltage drops below 80VAC on all phases (whichever occurs first). Once the ATS motor is de-energized, the Neutral Delay timer starts timing. Once the Neutral Delay timer times out the motor re-energizes to continue the transfer (see below). **Note:** Normally the load voltage will typically drop below the setpoint within 1 second when the source power switching device opens and therefore the “Find Neutral/Source Timer” never times out. The default setting of this timer (10 seconds) is intentionally set long so that it will not pre-maturely stop the ATS mechanism.

Transfer Neutral to Source– “Find Neutral/Source Timer” starts timing as soon as the Neutral Delay timer times out. During this period the motor is energized and moves the mechanism from the neutral to the alternate source. The power to the ATS motor will be de-energized when either the mechanism’s limit switch activates (i.e. external logic to the TSC 80) or the “Find Neutral/Source Timer” times out (whichever occurs first). **Note:** During the above 2 sequences the “Transfer Fail Alarm” logic is inhibited. Once the 2 sequences have been completed, the “Transfer Fail Alarm” logic will be re-enabled and will only be triggered if conditions as described in item A (Normal Steady State Condition) are sensed (limit switch and/or loss of load voltage).

For example, if the ATS mechanism fails to move (i.e. due to broken rod, motor failure or manual release plunger not re-engaged), the total time before a transfer fail will be initiated is 31 seconds (i.e. Find Neutral/Source Timer” 10 sec + Find Neutral/Source Timer” (10 sec)+ Limit Switch Failure & Loss of Load Voltage <80VAC = 31 seconds).

3.1.2.6.SERVICE ENTRANCE ATS

For Service Entrance Rated transfer switch applications, the transfer switch control logic will include external wiring to signal the transfer switch mechanism to move to the “Service Disconnected” position. In this mode the TSC 80’s transfer control outputs and Transfer Fail feature is disabled.

3.2. TEST MODES

3.2.1. UTILITY POWER FAIL SIMULATION (LOAD TEST)

To simulate a utility power failure condition, press the UTILITY POWER FAIL SIMULATE pushbutton on the Lexan faceplate. Hold the pushbutton on for approximately 5 seconds until the LED light above the pushbutton changes state. Once the mode is initiated, the engine start will be activated, once the engine accelerates to nominal voltage and frequency levels, the load will automatically transfer to the generator supply. To terminate the Utility Power Fail Test Mode, the Test pushbutton must be held on for approximately 5 seconds until the LED light above the pushbutton changes state. When the pushbutton is released the LED light will go out and, the load will re-transfer back to the utility supply following expiry of the Utility Return delay timer.

NOTE

The load will automatically re-transfer to the utility supply should the generator fail while on load.

3.2.2. AUTOMATIC PLANT EXERCISE LOAD TEST

To initiate a 30 minute /7 day weekly automatic plant exercise mode, press the GENERATOR EXERCISE Mode pushbutton on the Lexan faceplate. Hold the pushbutton on for approximately 5 seconds until the LED light above the pushbutton changes state. Once the mode is initiated, the engine will immediately start and transfer on load once nominal voltage and frequency levels have been obtained. The engine will remain operating on load until the plant exercise time delay period of 30 minutes expires, then the load will re-transfer back to the utility supply. The engine will be automatically re-tested on load every week (e.g.7 days) at the same time of day.

NOTES

1. The load will automatically re-transfer to the utility supply should the generator fail while in the test mode.
2. To bypass a 30 minute exercise run period, press and hold the Exercise pushbutton on for 5 seconds until the LED remains on.

The Generator Exercise LED light will operate as follows:

- LED ON - Exercise Timer is initiated, the 7 day timer is active and the generator is in the off state.
- LED FLASHING - Exercise Timer is initiated, the 30 minute run timer is active and the generator is running on loads.
- LED OFF - Exercise Timer is not initiated and the 7 day timer is not active.

To terminate the Generator Exercise Mode, the Exercise pushbutton must be held on for approximately 5 seconds until the LED light above the pushbutton starts flashing. When the pushbutton is released, the LED light will go out and the system will return to normal operation.

3.2.3. FOUR FUNCTION REMOTE TEST (FTS4 OPTION)

The function of the Four Position Test Switch Input is to allow operators to select various operating scenarios for test or maintenance purposes, in addition to the use of the faceplate mounted pushbuttons.

NOTE: When an external FTS4 switch is used, the TSC 80 operation as selected from the faceplate pushbuttons will be overridden.

OFF: Disables the engine start output from the transfer switch. If the primary source is available, and within normal limits, the TSC 80 will initiate a transfer to the primary source. The transfer switch will not automatically transfer to the secondary (alternate) source should the primary source fail.

AUTO: All automatic functions are enabled.

ENGINE START: (No load test) An engine start signal will be initiated and will remain on until the FTS4 is placed in another position. The engine will start if the engine's auto start controller is in the "Auto" mode. If the

primary source fails in this mode, and the secondary source is within parameters, the TSC 80 will initiate a transfer to the secondary source. When the Engine Start input is removed, the generator will continue to run if it has not operated for a time equal to or greater than the minimum run time (i.e. based on the Engine Cooldown Timer setting).

TEST: (Full load test) A primary source failure is simulated and an engine start signal will be initiated. When the secondary source is within normal limits, the TSC 80 will initiate a transfer to the secondary source. The system will remain in this state until the FTS4 is placed in another position or the secondary supply fails. Upon a secondary supply failure, if the primary supply is available, the TSC 80 will initiate a transfer to the primary supply. The Engine Cooldown time sequence will be initiated when the test mode is terminated.

3.2.4. REMOTE TEST

To activate a remote load test, a contact is to be remotely closed between terminal #44 and terminal #38. When the contact closes, and engine start will be activated and once the engine accelerates to nominal voltage and frequency levels, the load will automatically transfer to the generator supply. When the remote contact is opened, the load will re-transfer back to the utility supply following expiry of the Utility Return delay timer. The Engine Cooldown time sequence will be initiated when the test mode is terminated.

NOTE

The load will automatically re-transfer to the utility supply should the generator fail while on load.

3.3. TRANSFER FAIL FAULT RESET

To reset a Transfer Fail condition (i.e. When either the Load on Gen or Load on Utility LEDs are flashing and the ATS load is transferred to the alternate source), both Lexan faceplate pushbuttons (i.e. UTILITY POWER FAIL SIMULATE & GENERATOR EXERCISE MODE) must be held on for approximately 5 seconds until all LEDs on the Lexan start flashing and UTILITY POWER FAIL SIMULATE LED flashes in opposition. Once the alarm condition is reset, the load will automatically retransfer back to the original source if within normal limits.

3.4. LAMP TEST

To initiate a Lamp Test, both Lexan faceplate pushbuttons (i.e. UTILITY POWER FAIL SIMULATE & GENERATOR EXERCISE MODE) must be held on longer than 5 seconds until all LEDs on the Lexan illuminate in a flashing mode.

NOTE

The Lamp Test Function will also clear a transfer failure alarm and will allow active timers to be bypassed if the lamp test is held on for longer than 5 seconds.

3.5. TIMER BYPASS

To bypass an active timing sequence (e.g. utility return timer, cooldown timer, warmup timer) during operation, both Lexan faceplate pushbuttons (i.e. UTILITY POWER FAIL SIMULATE & GENERATOR EXERCISE MODE) must be held on for approximately 5 seconds until all LEDs on the Lexan start flashing and UTILITY POWER FAIL SIMULATE LED flashes in opposition.

4. CONFIGURATION INSTRUCTIONS

All user configuration of the TSC 80 controller is accomplished using either hardware jumpers or potentiometers located on the printed circuit board as per FIGURE 2. No software programming is required. The hardware jumpers and potentiometers are used for configuration of main operating parameters such as system voltage, frequency, phases, adjustable time delays, voltage sensor settings and frequency sensor settings. All configuration jumpers and potentiometers are set to factory default values as required for the Transfer Switch and should not require further setting.

4.1. CONFIGURATION JUMPERS

The following configuration jumpers are provided on the printed circuit board to program the TSC 80 controller:

WARNING

The configuration jumper settings must not be changed while the Transfer Switch and TSC 80 controller are energized. All sources of power to the transfer switch must be de-energized prior to changing any configuration jumper settings. Failure to do so may cause personnel injury and/or death.

4.1.1. SYSTEM VOLTAGE

Four jumpers are provided to set the required system operating voltage of the TSC 80 controller. Jumpers are provided for each typical system Phase-to-Phase Voltage (i.e. 600V, 480V, 380V, 240V).

To activate the required system voltage setting, a jumper must be placed across the 2 pins, adjacent to the text on the PCB. Only one jumper must be placed on the voltage selection jumpers. Failure to do so will cause improper operation.

NOTES

1. For 208V nominal system voltage, no jumpers are required on any of the voltage jumper pins.
2. For 3 phase 3 wire or high voltage applications utilizing 120V sensing input voltage, no jumpers are required on any of the voltage jumper pins and Terminal #43 must be jumpered to Terminal #38.
3. For nominal system voltages that are not provided by specific configuration jumper pins, contact Thomson Technology for further information.
4. If multiple jumpers are incorrectly left on the voltage selection pins, the highest voltage selected will have precedence.

When a system voltage is selected, the TSC 80's utility and generator under voltage setpoint percentage setting will be automatically programmed to correspond to the sensing input voltage (e.g. with a 600V system voltage selected, and a 80% under voltage potentiometer setting, the under voltage sensor will be activated below 540VAC).

NOTE

When a configuration jumper is not required, the jumper should be connected to only one pin of the header to conveniently store it for future use.

4.1.1.1.TSC 80 UNDER VOLTAGE SETPOINTS WITH NON-STANDARD SYSTEM VOLTAGES

When the Transfer Switch & TSC 80 transfer controller is applied to non-standard system voltages, the TSC 80 under voltage potentiometer setting percentages on the printed circuit board will not correspond to the correct voltage drop out setting.

To obtain the correct drop-out voltages using non-standard system voltages, the TSC 80 potentiometers need to have an offset percentage adjustment with the corresponding Voltage Jumper settings. These are shown in the following table for typical 85% drop-out under voltage setpoints.

System Voltage	ATS Transformer Tap Setting	TSC 80 Voltage Jumper Setting	85% Drop-out Voltage	TSC 80 Under voltage Potentiometer Setting
208V	208V tap	No jumper = 208V	177V	85%
220V	240V tap	240V	187V	78%
230V	240V tap	240V	195V	81%
240V	240V tap	240V	204V	85%
440V	480V tap	480V	374V	78%
460V	480V tap	480V	391V	81%
480V	480V tap	480V	408V	85%
575V	600V tap	600V	489V	82%
380V/50H z	392V tap (use 208V to 600V primary connection)	380V	323V	85%
400V/50H z	392V tap (use 208V to 600V primary connection)	480V	340V	71%

To obtain the most accurate setting of the potentiometer (other than visually on the printed circuit board), a Service Display Module (SDM) is recommended.

For other non-standard system voltages, the following formula can be used:

A) Desired Drop-out Voltage= Drop-out % x System Voltage

B) TSC 80 POT Setting = $\frac{(\text{Desired Drop-out voltage} \times 100)}{\text{TSC 80 Voltage Jumper Setting}}$

Example: for 440V system, 85% of 440V= .85 x 400V= 374V

$$\text{TSC 80 POT Setting} = \frac{(374 \times 100)}{480}$$

TSC 80 POT Setting = **78%**

NOTE

The TSC 80 voltage jumper setting must be set to be equal to the nominal system voltage level or the next highest setting available (e.g. 440V system voltage must use 480V jumper setting).

4.1.2. SYSTEM FREQUENCY

One jumper is provided to set the required system operating frequency of the TSC 80 controller.

- For 60Hz applications, no configuration jumper is required.
- For 50Hz applications, a jumper must be placed across the 2 pins, adjacent to the text on the PCB.

When a system frequency is selected, the TSC 80's generator frequency setpoint percentage setting will be automatically programmed to correspond to the sensing input frequency (e.g. with a 60Hz system frequency, and a 90% under frequency potentiometer setting, the under frequency sensor will be activated below 54.0 Hz).

NOTE

When a configuration jumper is not required, the jumper should be connected to only one pin of the header to conveniently store it for future use.

4.1.3. SYSTEM PHASES

One jumper is provided to set the required number of system phases for the TSC 80 controller.

- For 3 phase applications, no configuration jumper is required.
- For single-phase applications, a jumper must be placed across the 2 pins, adjacent to the text on the PCB. Phase C voltage sensing input is ignored in the single-phase mode.

NOTE

When a configuration jumper is not required, the jumper should be connected to only one pin of the header to conveniently store it for future use.

4.1.4. GEN EXERCISE LOAD TEST MODE (NO XFER)

A configuration jumper is provided to select the desired testing mode (i.e. load test with transfer or no-load test) for the 7 day/30 minute generator exercise function or for a remotely initiated Test mode. One jumper is provided to set the desired test mode as follows:

- Load Test Gen Exercise Test Mode: no program jumper is required.

NOTE

The Load Test mode is the factory default setting.

- No-Load Gen Exercise Test Mode: program jumper is required to be placed across the 2 pins, adjacent to the text on the PCB.

NOTE

Should utility power fail during a no-load test operation, the load will automatically transfer to the generator and will re-transfer back when utility power is restored to within normal conditions. The engine will continue to run until the 30 minute exercise time delay period expires.

NOTE

When a configuration jumper is not required, the jumper should be connected to only one pin of the header to conveniently store it for future use.

4.1.5. SECURE

A configuration jumper is provided to inhibit the test pushbuttons on the Lexan faceplate, for security purposes.

- For normal automatic transfer switch operation, no configuration jumper is required.
- To inhibit the test pushbuttons on the Lexan faceplate for security purposes, a jumper must be placed across the 2 pins, adjacent to the text on the PCB.

If the jumper was placed to inhibit the test pushbuttons subsequent to an Exercise Test mode being activated, the Gen Exercise test mode will be immediately terminated. If utility power fail test mode is selected prior to placing the inhibit configuration jumper on, the test continue to operate until manually terminated by pressing the Test pushbutton for 5 seconds.

NOTE

When a configuration jumper is not required, the jumper should be connected to only one pin of the header to conveniently store it for future use.

4.2. ADJUSTMENT POTENTIOMETERS

Eight adjustment potentiometers are provided on the TSC 80 controller printed circuit board. Refer to Figure #2 which illustrates how the potentiometers are arranged on the printed circuit board. A listing of available features which are user adjustable via the PCB potentiometers is shown in Table #1. A small flat blade screwdriver is required to adjust the potentiometers. Turning the potentiometer in the clockwise position will cause an increase in function setting and visa-versa for counter-clockwise pot rotation.

TABLE 1
USER ADJUSTABLE FEATURES

Function	Factory Default Setting	Range
Engine Start Timer	3 seconds	0-60 sec
Engine Warmup Timer	2 seconds	0-60 sec
Engine Cooldown Timer	2 minutes	0-30 min
Utility Return Timer	2 minutes	0-30 min
Neutral Delay Timer	3 seconds	0-60 sec
Utility Under Voltage Sensor (Drop-Out Setting)	85%	70-95%
Generator Under Voltage Sensor (Drop-Out Setting)	85%	70-95%
Generator Frequency Sensor	90%	70-90%

4.2.1. UTILITY UNDER VOLTAGE SETPOINT

A potentiometer is provided to adjust the setpoint of the TSC 80's utility under voltage sensor. The under voltage setting is expressed in percentage of system voltage setting with an adjustable range of 70-95% (e.g. If system voltage configuration jumper is set for 600V, an 80% under voltage setting will correspond to an actual 540VAC setpoint.)

NOTE

The actual under voltage setpoint voltage is calculated based on the TSC 80 voltage configuration jumper setting (i.e. nominal system voltage) and the potentiometer setting. Actual system operating voltage should not be used to calculate the under voltage setpoint.

The under voltage setting is for a falling utility voltage (i.e. “drop-out” setting) on any one phase. The under voltage sensor will reset to normal when the utility voltage rises 5% above the “drop-out setting (i.e. differential value). Example: if under voltage is adjusted to an 80% drop-out value, it will reset at 85% voltage. The 5% differential value is not programmable.

NOTE

To override momentary under voltage fluctuations, the under voltage sensor is provided with a transient time delay period of 5 seconds which is non-adjustable.

Refer to Table 1 for the factory default settings of the utility under voltage sensor.

4.2.2. GENERATOR UNDERVOLTAGE SETPOINT

A potentiometer is provided to adjust the setpoint of the TSC 80's generator under voltage sensor. The under voltage setting is expressed in percentage of system voltage setting with an adjustable range of 70-95% (e.g. If system voltage configuration jumper is set for 600V, an 80% under voltage setting will correspond to an actual 540VAC setpoint.)

NOTE

The actual under voltage setpoint voltage is calculated based on the TSC 80 voltage configuration jumper setting (i.e. nominal system voltage) and the potentiometer setting. Actual system operating voltage should not be used to calculate the under voltage setpoint.

The under voltage setting is for a falling generator voltage (i.e. “drop-out” setting) on any one phase. The under voltage sensor will reset to normal when the generator

voltage rises 5% above the “drop-out setting (i.e. differential value). Example: if under voltage is adjusted to an 80% drop-out value, it will reset at 85% voltage. The 5% differential value is not programmable.

NOTE

To override momentary under voltage fluctuations, the under voltage sensor is provided with a transient time delay period of 5 seconds which is non-adjustable.

Refer to Table 1 for the factory default settings of the generator under voltage sensor.

4.2.3. GENERATOR UNDER FREQUENCY SETPOINT

A potentiometer is provided to adjust the setpoint of the TSC 80's generator under frequency sensor. The under frequency setting is expressed in percentage of system frequency setting with an adjustable range of 70-90% (e.g. If system frequency configuration jumper is set for 60Hz, an 90% under frequency setting will correspond to an actual 54Hz setpoint.).

NOTE

The actual under frequency setpoint voltage is calculated based on the TSC 80 voltage configuration jumper setting (i.e. nominal system frequency) and the potentiometer setting. Actual system operating frequency should not be used to calculate the under frequency setpoint.

The under frequency setting is for a falling generator frequency (i.e. “drop-out” setting) on any one phase. The under frequency sensor will reset to normal when the generator frequency rises 0.5% above the “drop-out setting (i.e. differential value). Example: if under frequency is adjusted to an 80% drop-out value (i.e. 48.0Hz), it will reset at 48.3Hz. The 0.5% differential value is not programmable.

NOTE

To override momentary under frequency fluctuations, the under frequency sensor is provided with a transient time delay period of 5 seconds which is non-adjustable.

Refer to Table 1 for the factory default settings of the generator under frequency sensor.

4.2.4. ENGINE START DELAY

A potentiometer is provided to adjust the TSC 80's Engine Start Delay timer. The engine start signal will be initiated following expiry of the start delay timer. Select desired Engine Start time delay in seconds. The range of setting is 0 to 60 seconds. If no delay is required, set this time delay to zero.

NOTE

The output relay is normally energized when the utility power is within limits and de-energizes to start the engine.

Refer to Table 1 for the factory default settings of the Engine Start Delay timer.

4.2.5. ENGINE WARMUP DELAY

A potentiometer is provided to adjust the TSC 80's Engine Warmup Delay timer. A transfer to the generator supply will be initiated when the voltage and frequency are within limits and upon expiry of the Engine Warmup delay timer. The range of setting is 0 to 60 seconds. If no delay is required, set this time delay to zero.

Refer to Table 1 for the factory default settings of the Engine Warmup Delay timer.

4.2.6. ENGINE COOLDOWN DELAY

A potentiometer is provided to adjust the TSC 80's Engine Cooldown Delay timer. The Engine Cooldown period will be initiated once the load has transferred from the generator supply. The engine start signal will be maintained until expiry of the cooldown delay timer. The range of setting is 0 to 120 seconds. If no delay is required, set this time delay to zero.

Refer to Table 1 for the factory default settings of the Engine Cooldown Delay timer.

4.2.7. UTILITY RETURN DELAY

A potentiometer is provided to adjust the TSC 80's Utility Return Delay timer. The Utility Return delay period will be initiated once the utility supply has returned within limits following a utility power failure condition. The range of settings is 0 to 30 minutes. If no delay is required, set this time delay to zero.

NOTE

The utility return delay will be bypassed should the generator fail during the time delay period.

Refer to Table 1 for the factory default settings of the Utility Return Delay timer.

4.2.8. NEUTRAL DELAY

A potentiometer is provided to adjust the TSC 80's Neutral Delay timer. The neutral delay time period will be initiated once the load bus voltage drops below the dead-bus threshold value when both of the supply power switching devices are open during a transfer sequence. Select desired neutral delay time in seconds. The range of settings is 0 to 60 seconds. If no delay is required, set this time delay to zero.

NOTE

The neutral delay will be bypassed should the operating power fail for longer than the timer setting.

Refer to Table 1 for the factory default settings of the Neutral Delay timer.

5. TSC 80 TYPICAL CONNECTION DIAGRAM

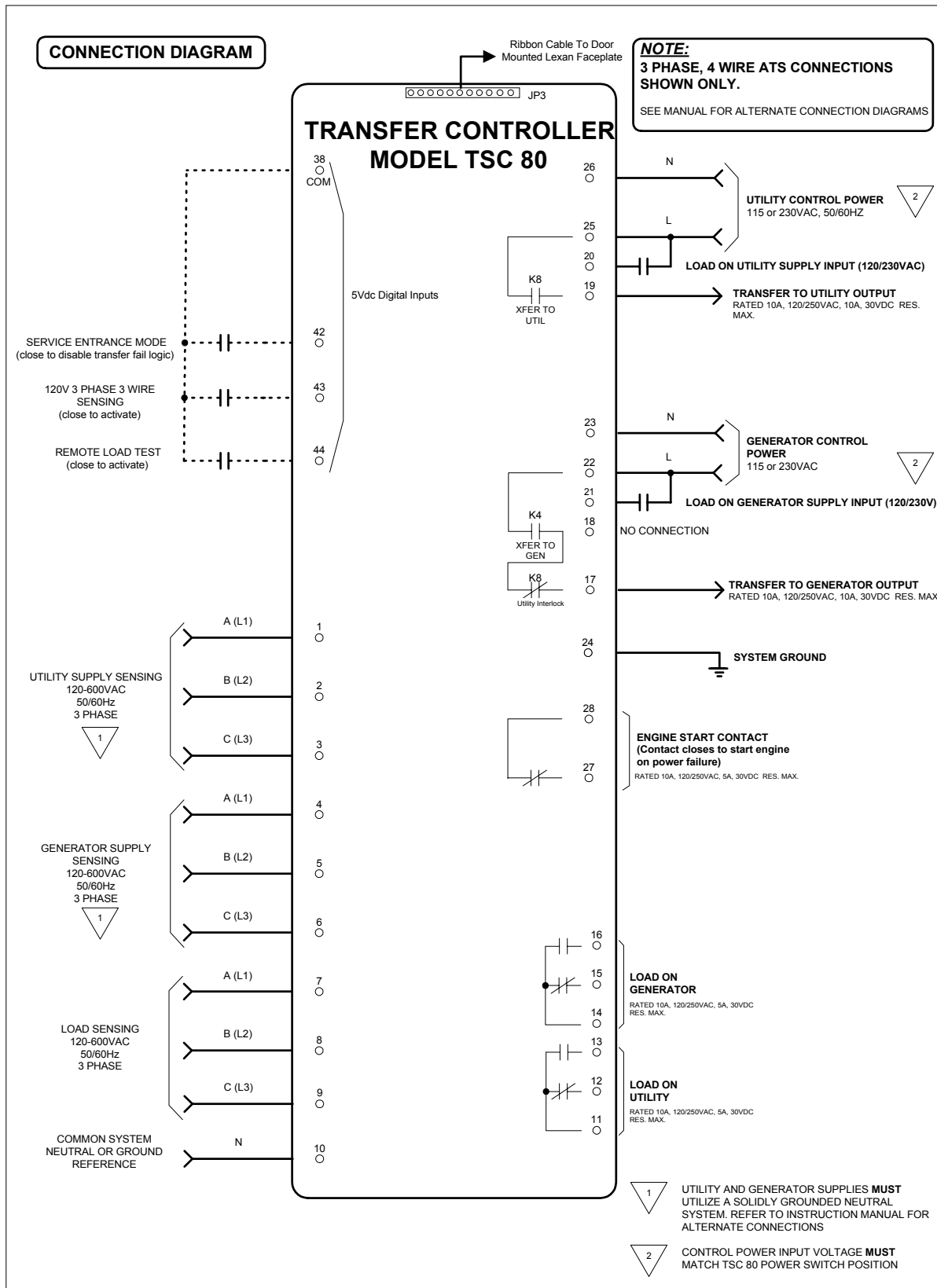

FULL FILENAME

DRAWING7

REVISED 04-10-22

6. TSC 80 SPECIFICATIONS

- POWER SUPPLY:
 - 115 or 230VAC nominal (+10% -30%)
 - 50/60Hz
 - 6VA nominal (no external load connected)

- VOLTAGE SENSING:
 - Direct 120-600VAC nominal, single or 3 phase
 - 50/60Hz
 - +/- 1.0% accuracy of setting @ 25°C

- OPERATING TEMPERATURE:
 - 40°C to +50°C

- OUTPUT CONTACTS (Form C, 10A, 120/250VAC resistive)
 - Engine Start
 - Load on Utility
 - Load on Generator

- OUTPUT SIGNALS (120/250VAC resistive load)
 - Transfer to utility 10A
 - Transfer to generator 10A

7. TROUBLESHOOTING

A number of problems can cause the TSC 80 controller not to function properly. Refer to the following list of typical problems. Consult the factory for any detailed information or for any problems not listed.

NOTE

An optional hand held, plug-in Service Display Module (SDM) is available for the TSC 80 Transfer Controller. The SDM module provides an LCD screen to display additional detailed information on the operation and settings of the TSC 80 controller for simplified servicing/trouble shooting procedures. For detailed information, refer to the separate SDM module instruction manual (PM065).

CAUTION!!!

Before opening the Transfer Switch enclosure to perform any service task, it is imperative to isolate the transfer switch from any possible source of power. Failure to do so may result in serious personal injury or death due to electrical shock.

Service procedures must be undertaken by qualified personnel only!

Symptom

- Will not re-transfer to utility source upon restoration

Possible Causes

- A test mode has been activated
- Utility voltage is outside the pre-programmed limits (check utility source for adequate voltage)
- A loose control connection
- Faulty auxiliary contact in the ATS motor circuit
- Defective ATS Motor
- Defective TSC 80 controller (verify output signals with circuit board mounted diagnostic LED's)
- TSC 80 has "Transfer Fail" alarm activated which is indicated by a flashing "Load on Utility" LED which is located on the Lexan faceplate. Determine cause of alarm and rectify before TSC 80 is reset

- Will not transfer to generator source upon failure of utility source

- Generator set not producing enough voltage/frequency or output circuit power switching device open

Symptom

Possible Causes

- Warmup time delay function has not timed out (verify TSC

- | | |
|--|--|
| <ul style="list-style-type: none"> - Transfer to generator source without a power failure in the utility source
 - Generator does not start up or stop when it should
 - No time delay when there should be
 - power is not available at the load terminals but the utility or generator power switching device appears to be closed to a live source
 - Engine runs for no apparent reason | <ul style="list-style-type: none"> 80 timer setting) - A loose control connection - Faulty auxiliary contact in the ATS motor circuit - Defective ATS Motor - Defective TSC 80 controller (verify output signals with circuit board mounted diagnostic LED's) - TSC 80 has "Transfer Fail" alarm activated which is indicated by a flashing "Load on Generator" LED which is located on the Lexan faceplate. Determine cause of alarm and rectify before TSC 80 is reset
 - A test mode has been activated - Defective TSC 80 controller (verify output signals with circuit board mounted diagnostic LED's) - Loose or broken wire to the utility voltage sensing terminals on the TSC 80 controller - Utility supply voltage is slightly below voltage sensing setpoints. Compare TSC 80 program voltage setpoints with actual utility voltage. - Utility power switching device has tripped due to an over current condition (Service Entrance type ATS) and TSC 80 "Transfer Fail" alarm activated. Determine cause of alarm and rectify before TSC 80 is reset
 - Verify remote engine control panel is set for automatic mode.
Verify the FTS4 selector is not in the Off, Engine Start or Test positions
 - Verify time delay function setting of TSC 80 potentiometer.
Verify load bus voltage decay during transfer to enable neutral delay timer
 - The power switching device's trip unit (service entrance type ATS) has tripped on a fault on the system. Correct the fault, and manually reset the power switching device in the transfer switch by moving it off and then on again with the manual operating handle
 - Verify the TSC 80 has not been set for test operation. |
|--|--|

NOTE

There are no user serviceable components located on the TSC 80 printed circuit board. If the TSC 80 controller is deemed to be defective it must be returned to the Thomson Technology Factory for repair or replacement. Please refer to *SECTION 9* for further detailed on product return procedures required.

8. REPLACEMENT PARTS

The TSC 80 controller is comprised of 3 component pieces, which may be ordered as replacement parts as follows:

TSC 80 Controller Board c/w Lexan Face plate & rear cover - Part Number TSC80SR

When ordering replacement parts please provide the following information:

1. Transfer Switch Model code (e.g. TS 873AA0200AS)
2. Transfer Switch Serial Number (e.g. W-022345)

The above information can be found on the transfer switch rating plate located on the outside of the ATS door.

NOTE

There are no user serviceable/replaceable components located on the TSC 80 printed circuit board. If the TSC 80 controller is deemed to be defective it must be returned to the Thomson Technology Factory for repair or replacement. Please refer to *SECTION 10* for further details on product return procedures.

9. PRODUCT RETURN POLICY

Thomson Technology uses a Return Material Authorization (RMA) process. Please complete the [Return Authorization Request Form](#) (available on our web page) for return of goods, warranty replacement/repair of defective parts, or credit consideration and fax to the appropriate department.

Returns only: Sales Fax (604) 888-5606

Warranty replacement/Warranty Repair: Service Fax (604) 888-3370.

Upon receipt of your request, Thomson Technology will confirm with a copy of our Order Acknowledgement via fax advising the RMA number which should be used to tag the defective controller prior to shipment.

