

# OPERATION AND MAINTENANCE MANUAL

## TRANSFER SWITCH CONTROL PANEL

### MX100 MICROPROCESSOR CONTROLLER

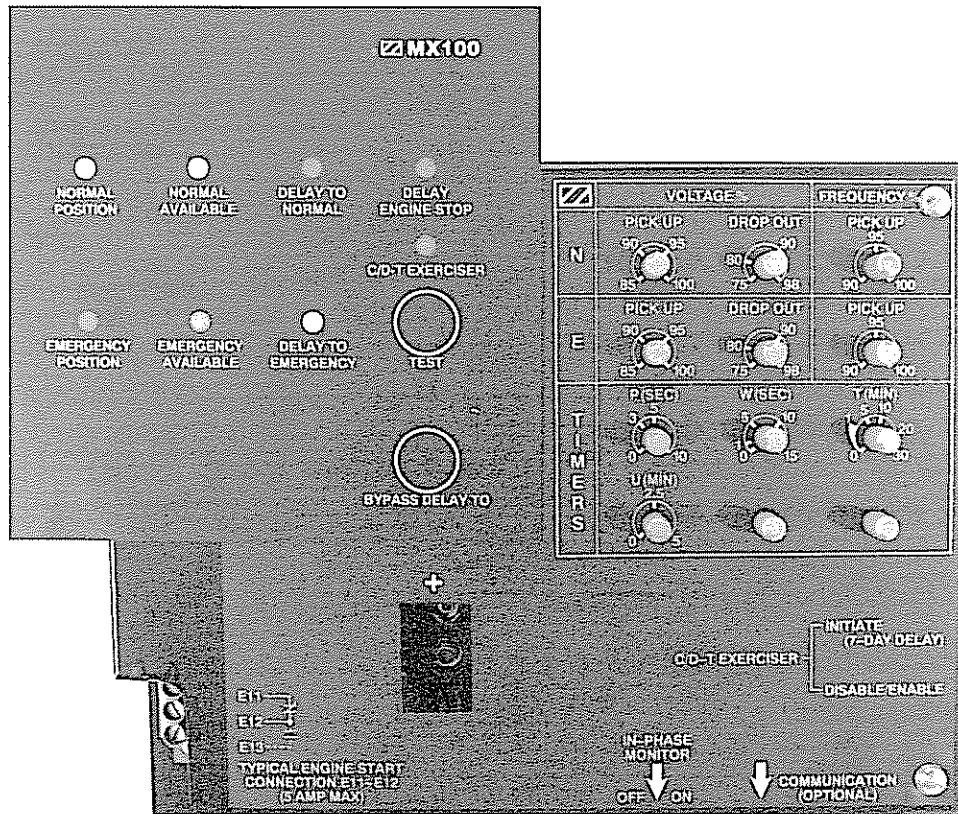

# Table of Contents

	<b>Page</b>
Safety.....	1
Final Equipment Inspection .....	1
Equipment Inspection and Storage .....	1
Installation .....	2
Engine Start Control Connections .....	2
Initial Energization .....	3
Operation and Testing.....	4
Standard Transition ATS Testing (w/o A6 or T3/W3) .....	4
Delayed Transition ATS Testing.....	5
Standard Transition ATS Testing (w/A6 or T3/W3).....	6
Operation Sequence .....	8
Control Features and Options .....	9
Control Features .....	9
Control Options .....	10
User Settings.....	11
Voltage and Frequency Pickup/Dropout Adjustments .....	12
Timer Adjustments .....	12
Relay/Transformer Box (R/T Box).....	14
Standard Transition .....	14
Delayed Transition.....	15
Standard Transition R/T Box Schematic .....	16
Delayed Transition R/T Box Schematic .....	16
Troubleshooting and Diagnostics.....	17
General Troubleshooting Chart .....	17
Diagnostic Annunciation .....	18
Standard Transition ATS (two position ATS) .....	18
Delayed Transition ATS (three position ATS) .....	19
Standard Transition ATS (with A6) .....	20

# Safety

## ▲ DANGER

### HAZARDOUS VOLTAGE (Can Cause Severe Injury or Death)

Turn OFF all power before installation, adjustment, or removal of transfer switch or any of its components.

Installation for each ATS is detailed in the information package which includes:

- Operation and Maintenance Manual for Control Panel (this manual)
- Power Panel Manual
- Specific Schematics Supplied With Each Transfer Switch

## Final Equipment Inspection

Prior to energizing the transfer switch:

1. Remove any debris incurred due to shipment or installation. **DO NOT** use a blower since debris may become lodged in the electrical and mechanical components and cause damage. Use of a vacuum is recommended.
2. Verify that all cabled connections are correct and that phase rotation of both sources match.
3. Check engine start connections and verify the correct connection of all control wires.
4. Check settings of all timers and adjust as necessary. Also adjust any optional accessories as required.
5. Check the integrity of power connections by verifying actual lug torque values as specified in the power panel manual.
6. Make sure that all covers and barriers are installed and properly fastened.

**NOTE:** Power Panels ship from Zenith in the Normal Position.

## Equipment Inspection and Storage

Immediately inspect the transfer switch when received to detect any damage which may have occurred during transit. If damage is found or suspected, file claims as soon as possible with the carrier and notify the nearest Zenith representative.

Before installation, it is necessary to store the transfer switch in a clean dry place, protected from dirt and water. Provide ample air circulation and heat, if necessary, to prevent condensation.

Storage Temperature: -30 C to + 85 C (-22 F to +149 F)

Operating Temperature (Ambient): -20 C to +75 C (-4 F to +167 F) [40-260 Amps]  
-20 C to +60 C (-4 F to +104 F) [400-4000 Amps]

Humidity: 5% to 95% (non-condensing)

# Installation

**▲ DANGER**

**HAZARDOUS VOLTAGE  
(Can Cause Severe Injury or Death)**

Turn OFF all power before installation, adjustment, or removal of transfer switch or any of its components.

## Engine Start Control Connections

Engine-start control wires connect to control terminals below of the MX100. Engine start terminals are indicated by a schematic symbol (the symbol indicates the contact state for a de-energized Normal source). Figure 1 shows the engine-start contacts.

Make all other necessary control connections to the control panel terminal blocks per the schematics supplied with the ATS. **All control wires (18-12 AWG) must be torqued to 19 in-lbs.**

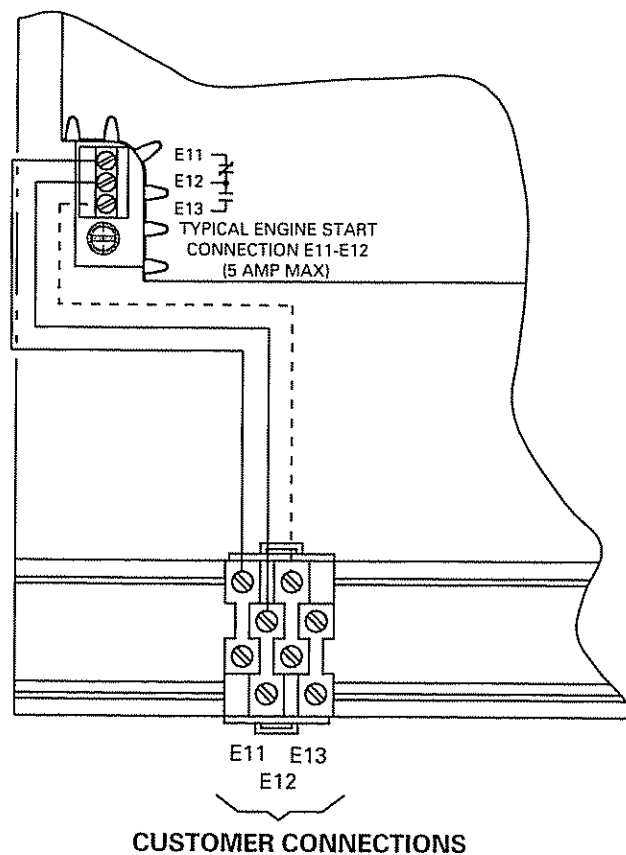

Figure 1 - Din Rail

# Installation *(cont'd)*

## ▲ DANGER

### HAZARDOUS VOLTAGE (Can Cause Severe Injury or Death)

Turn OFF all power before installation, adjustment, or removal of transfer switch or any of its components.

## Initial Energization

Functional testing of the ATS consists of electrical tests described in this section. Before proceeding, refer to the information package supplied with the ATS and read and understand the information on all accessories provided. (Caution: Certain accessories, per specific schematics, can inhibit automatic transfer. See Section 3.)

After all options and accessories are checked and verified, follow these steps to set up the ATS. Refer to MX100 display Figure 2. The annunciation LEDs illuminate to indicate (1) source availability, (2) ATS position, and (3) MX100 control function (timing).

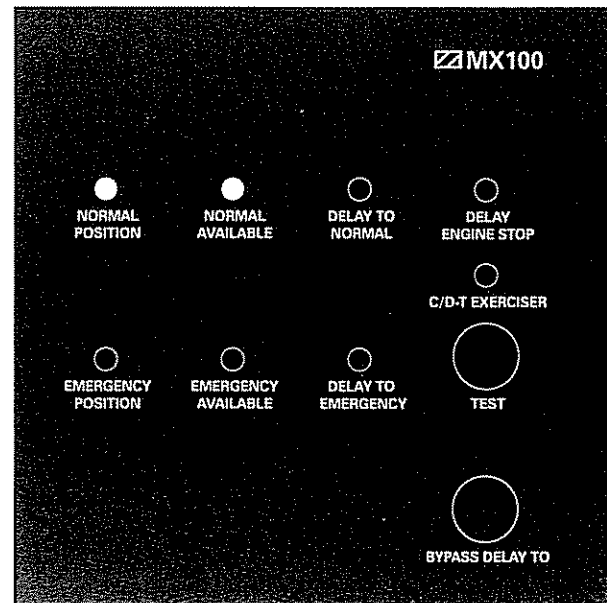

Figure 2 - Standard Transition  
Annunciation LEDs and Test Switch

## ▲ CAUTION

Engine Gen-Set could start when engine control wires are attached.

**NOTICE:** If LEDs are flashing, refer to Troubleshooting and Diagnostics.

**Step 1:** If equipped with the disconnect switch (DS) option, turn to INHIBIT. Close the external (up-stream) Normal circuit breaker. The Normal Available and Normal Position LEDs illuminate. (If the Normal Available LED does not illuminate verify that Normal source voltage is above the preset pick-up value.) On initial start-up, the Delay to Engine Stop Timing LED will illuminate for the duration of its setting.

**NOTICE:** Gen-Set will start and run while Delay to Engine Stop is timing.

**Step 2:** Close the external (up-stream) Emergency line circuit breaker and start the engine generator in MANUAL mode. When the voltage and the frequency reach preset values, the Emergency Available LED will illuminate.

**Step 3:** Verify the line-to-line voltages at the Emergency line terminals, and verify that the Emergency and Normal source phase rotations are the same (either A-B-C or A-C-B).

**Step 4:** After the sources have been verified, shut down the engine generator (place in AUTOMATIC mode). The Emergency Available LED will turn off.

**NOTICE:** Engine generator will continue to run if Delay to Engine Stop Timing LED is illuminated.

**Step 5:** Turn the DS (disconnect switch) to ENABLE if so equipped. Make a final inspection of the ATS and close and lock the cabinet door.

# Operation and Testing

## Standard Transition ATS Testing (w/o A6 or T3/W3)

For this test description, please refer to MX100 standard transition display *Figure 2*.

Initiate testing with the ATS in Normal position and Normal power available (Normal Position and Normal Available LEDs illuminated). **Press and hold the test switch until transfer (releasing the test switch prematurely will abort the test)**. The delay to engine start timer (P) begins its timing cycle. After the P timer has completed its timing cycle, the engine start contacts close to start the generator.

When Emergency voltage and frequency reach preset pickup points the Emergency Available LED illuminates. Simultaneously, the delay to emergency timer (W) begins its timing cycle and the Delay to Emergency LED illuminates. When the W time delay is completed the switch will transfer to emergency. The Delay to Emergency and Normal Position LEDs go off, and the Emergency Position LED illuminates.

**Release the test switch to start retransfer to Normal.** The delay to normal timer (T) begins its timing cycle illuminating the Delay to Normal LED. When the T timer has completed its timing cycle the switch will transfer into Normal. The Delay to Normal and Emergency Position LEDs go off, and the Normal Position LED illuminates. The delay engine stop timer (U) begins its timing cycle and the Delay Engine Stop LED illuminates. The generator runs unloaded for the duration of the U timing cycle. When the timer completes its timing cycle, the generator will stop. The Delay Engine Stop and the Emergency Available LEDs go off.

### ▲ NOTICE

**A periodic test of the transfer switch under load conditions is recommended to insure proper operation.  
(See National Electric Code articles 700 and 701).**

Standard Transition Transfer Sequence (w/o A6 or T3/W3)	LED Annunciation Status						
	Normal Position	Normal Available	Emergency Position	Emergency Available	Delay to Normal	Delay to Emergency	Delay Engine Stop
Normal Position	●	●					
W Time Delay	●	○		●		●	
Emergency Position		○	●	●			
T Time Delay		●	●	●	●		
Normal Position/ Engine Overrun Timer	●	●		●			●

○ Illuminated only when running TEST, not on Normal power failure

## Delayed Transition ATS Testing

Refer to Delayed Transition display Figure 3. Initiate testing with the ATS in Normal position and Normal power available (Normal Position and Normal Available LEDs illuminated). Press and hold the test switch until transfer (releasing the test switch prematurely will abort the test).

The delay to engine start timer (P) begins its timing cycle. After the P time delay the engine start contacts close to start the generator.

When Emergency voltage and frequency reach the preset pickup points the Emergency Available LED illuminates. Simultaneously, the delay to open normal timer (W) begins its timing cycle and the Delay to Open Normal LED illuminates. After the W time delay the ATS transfers out of Normal position into the Open position. The Delay to Open Normal and Normal Position LEDs go off, and the Open Position and Delay to Emergency LEDs illuminate. (Releasing the test switch now will allow the test to continue.)

Time delay to emergency (DW) then begins. When the DW time delay is completed the switch will transfer to Emergency. The Delay to Emergency and Open Position LEDs go off, and the Emergency Position LED illuminates.

The MX100 microcontroller will automatically begin the retransfer sequence to Normal. The delay to open emergency (T) timer begins its timing cycle and the Delay to Open Emergency LED illuminates. When the T timer has completed its timing cycle, the ATS transfers to the open position. The Delay to Open Emergency and the Emergency Position LEDs turn off, and the Open Position and the Delay to Normal LEDs illuminate. The delay to normal timer (DT) then begins its timing cycle illuminating the Delay to Normal LED. When the DT timer has completed its timing cycle the ATS will transfer out of the open position into the Normal position. Delay to Normal and the Open Position LEDs turn off, and the Normal Position LED illuminates.

The delay engine stop timer (U) begins its timing cycle and the Delay Engine Stop LED illuminates. The generator runs unloaded for the duration of the U timing cycle. Upon completion of the U time delay, the generator will stop. The Delay Engine Stop and the Emergency Available LEDs go off.

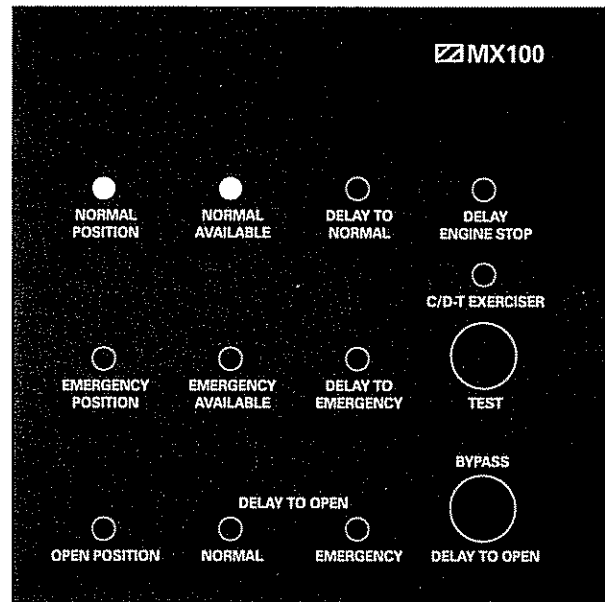

Figure 3 - Delayed Transition Annunciation LEDs and Test Switch

# Operation and Testing *(cont'd)*

## ▲ NOTICE

A periodic test of the transfer switch under load conditions is recommended to insure proper operation.  
(See National Electric Code articles 700 and 701).

LED Annunciation Status										
Delay Transition Transfer Sequence	Normal Position	Normal Available	Emergency Position	Emergency Available	Delay to Normal	Delay to Emergency	Delay Engine Stop	Open Position	Delay to Open Normal	Delay to Open Emergency
Normal Position	●	●								
W Time Delay	●	○		●					●	
Open Position/ DW Time Delay		○		●		●		●		
Emergency Position		○	●	●						
T Time Delay		●	●	●						●
Open Position/ DT Time Delay		●		●	●			●		
Normal Position/ Engine Overrun Timer	●	●		●			●			

○ Illuminated only when running TEST, not on Normal power failure

## Standard Transition ATS Testing (w/A6 or T3/W3)

Refer to Standard Transition w/A6 or T3/W3 display Figure 4. Initiate testing with the ATS in Normal position and Normal power available (Normal Position and Normal Available LEDs illuminated). Press and hold the test switch until transfer (releasing the test switch prematurely will abort the test).

The delay to engine start timer (P) begins its timing cycle. After the P time delay the engine start contacts close to start the generator.

When Emergency voltage and frequency reach the preset pickup points the Emergency Available LED illuminates. Simultaneously, the delay to emergency timer (W) begins its timing cycle and the Delay to Emergency LED illuminates. After the W time delay the ATS presignal is initiated. The Delay to Emergency and Normal Position LEDs go off, and the Presignal On and Presignal Time Delay to Emergency LEDs illuminate. (Releasing the test switch now will allow the test to continue).

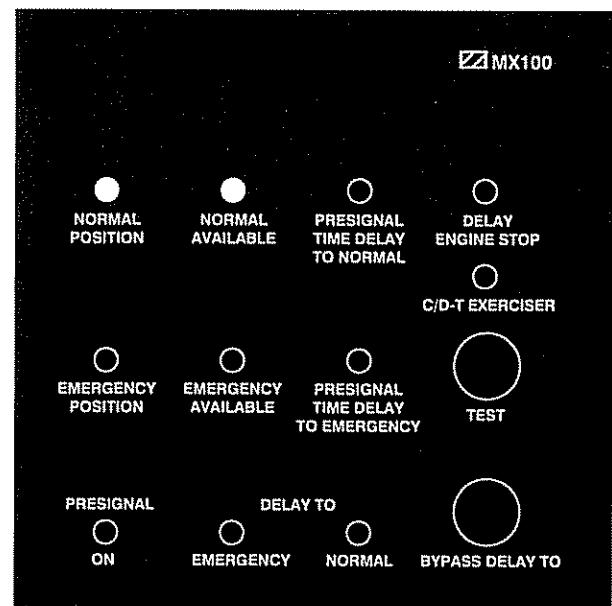

Figure 4 - Standard Transition w/A6 Annunciation LEDs and Test Switch

# Operation and Testing *(cont'd)*

Presignal Time Delay to emergency (TA6) then begins. When the TA6 time delay is completed, the switch will transfer to Emergency. The Presignal Time Delay to Emergency and Presignal On LEDs go off, and the Emergency Position LED illuminates.

The MX100 microcontroller will automatically begin the retransfer sequence to Normal. The delay to normal (T) timer begins its timing cycle and the Delay to Normal LED illuminates. When the T timer has completed its timing cycle, the ATS presignal is initiated. The Delay to Normal and the Emergency Position LEDs turn off, and the Presignal On and the Presignal Time Delay to Normal LEDs illuminate. The Presignal Time Delay to normal (TA5) then begins. When the TA5 timer has completed its timing cycle, the ATS will transfer to the Normal position. Presignal Time Delay to Normal and Presignal On LEDs turn off, and the Normal Position LED illuminates.

The delay engine stop timer (U) begins its timing cycle and the Delay Engine Stop LED illuminates. The generator runs unloaded for the duration of the U timing cycle. Upon completion of the U time delay, the generator will stop. The Delay Engine Stop and the Emergency Available LEDs go off.

## ▲ NOTICE

**A periodic test of the transfer switch under load conditions is recommended to insure proper operation. (See National Electric Code articles 700 and 701).**

LED Annunciation Status										
Standard Transition Transfer w/A6 or T3/W3 Sequence	Normal Position	Normal Available	Emergency Position	Emergency Available	Presignal Time Delay to Normal	Presignal Time Delay to Emergency	Delay Engine Stop	Presignal On	Delay to Emergency	Delay to Normal
Normal Position	●	●								
W Time Delay	●	○		●					●	
Open Position/ TA6 Time Delay		○		●		●		●		
Emergency Position		○	●	●						
T Time Delay		●	●	●						●
Open Position/ TA5 Time Delay		●		●	●			●		
Normal Position/ Engine Overrun Timer	●	●		●			●			

○ Illuminated only when running TEST, not on Normal power failure

The MX100 continuously monitors source voltage. In the event that Normal voltage falls below a preset drop-out value, the unit will perform in exactly the same way as noted in the test procedure (either standard transition or delayed transition).

## Operation Sequence

**Normal Power Failure.** When Normal voltage has fallen below the preset dropout value, the engine start (P) timer begins its timing cycle (factory set 3 seconds). The P timer allows for momentary undervoltage conditions in the Normal source without triggering the generator to start. If the Normal voltage remains below the dropout point throughout the P timing cycle, a generator start signal will be sent. The MX100 then monitors generator voltage and frequency to determine if they are within preset parameters. When the generator voltage and frequency reach acceptable limits the W timer begins its timing cycle. The W timer governs either the time delay for transfer to Emergency or to the open position (standard or delayed transition, respectively). The W timer (typically 1 second) assures that the generator voltage and frequency are stable before transfer.

The transfer to Emergency sequence is then completed as follows:

*Standard Transition*—after the W time delay, the ATS transfers to Emergency position and load power is supplied by the generator.

*Delayed Transition*—following the W time delay, the switch opens out of Normal to the Open position. The DW timer is activated. The DW time delay is typically set to 5 seconds. After the DW time delay, the switch completes transfer to Emergency.

*Standard Transition w/A6 or T3/W3*—following the W time delay, the presignal is initiated. The TA6 timer is started. The TA6 time delay is typically set to 5 seconds. After the TA6, the ATS transfers to Emergency.

**Restoration of Normal Power.** When Normal power reaches the preset pickup value, the T timer begins its timing cycle (factory set 30 minutes). The T timer is used to ensure that the Normal source has fully restored before retransfer. If Normal voltage remains above the pickup values for the duration of the T timer, transfer to Normal position is performed. Retransfer is accomplished as follows:

*Standard Transition*—ATS transfers to the Normal position and the load power is supplied by utility.

*Delayed Transition*—the switch opens out of Emergency to the Open position. The DT timer activates, typically set to 5 seconds. After the DT time delay, the switch completes transfer to Normal.

*Standard Transition w/A6 or T3/W3*—following the T time delay, the presignal is initiated. The TA5 timer is started. The TA5 time delay is typically set to 5 seconds. After the TA5, the ATS transfers to Normal.

The U timer then times out (factory set 5 minutes) to allow the generator to run unloaded for a cooldown period.

# Control Features and Options

## Control Features

**A6.** Motor load disconnect capability (standard transition only). Ensures that closing into the oncoming source does not create a large disturbance due to phase angle difference between the load and the oncoming source. Motor loads can be disconnected for an adjustable period of 0-60 seconds prior to transfer of the main contacts. This feature includes LEDs to indicate when the motor load is disconnected.

**CDT Exerciser.** A built in 7 day exerciser timer is incorporated into the MX100, (standard feature, all models). Pressing the initiate switch will start a timer that will continue for 167 hours and 40 minutes. Along with initiating the timer, an LED will illuminate to indicate that the timer has been started. After 167 hours and 40 minutes, a load test (ATS transfers to Emergency) or a no load test (ATS signals the genset to start but does not transfer) occurs. The exercise mode is determined by the MX100 PCboard jumper location (TSL = load, TSNL = no load). The test lasts for 20 minutes. The CDT Exerciser LED will flash when the exercising is in progress. This 20 minute exercise does not include the time delay to retransfer to normal (T timer) when the ATS is transferred (load test) or the time delay engine stop (U timer) for either load or no load tests. Disabling the exercise event is done by pressing the disable/enable switch. When this is done the exercise event will not occur, although the timer will not be affected. The CDT Exerciser LED will turn off when the disable/enable switch is pressed for the first time after initiating the timer. Pressing the disable/enable switch again will re-enable the exercise event while turning the CDT Exerciser LED back on. The time of the exercise event can be changed by re-initiating the event. The time that the button is pressed will be the end of the exercise event one week later.

### CDT Exerciser Notes

1. To avoid unintentional initiating/disabling the button should be held down for 3 seconds when pressed.
2. A 9V battery is supplied to prevent CDT exercise timer from losing it's "set exercise time" in the event of an extended power outage. The battery can back up the processor for up to 8 hours. The battery should be replaced if it has supplied power to the microprocessor for an extended outage.
3. The 9V battery cannot be plugged into a PCboard that is deenergized. The PCboard includes large capacitors that the battery will not be able to charge. If the capacitors are charged, the battery will still discharge eventually due to the load of the PCboard. Therefore, do not install a battery until the PCboard is energized. The battery will then be able to maintain the CDT "set exercise time" in the event of an extended outage.

**R50.** In-phase monitor (standard transition w/o A6 only). R50 ensures that the phase angle difference between the load voltage and the oncoming source voltage is minimal (live source-to source transfers). The feature requires a fast acting transfer switch, therefore is only available with a standard transition ATS. The in-phase monitor is suitable for isochronous through 3% droop governors. The microprocessor anticipates the synchronized condition

# Control Features and Options *(cont'd)*

by monitoring the phase angle and frequency differential between the sources. Then it signals a transfer at the precise moment to ensure minimal phase difference between the sources at the completion of transfer. R50 also includes a PCboard-mounted switch to override the in-phase monitor function if necessary. The override toggle switch is located below the MX100 cover, but the toggle position to enable or disable the function is clearly indicated on the cover.

**YEN.** Pushbutton time delay transfer/retransfer bypass.

## Control Options

Five control input options can be used with the MX100:

- 6A
- C
- C/D
- Q2
- ZNET100

**Note:** Consult the factory when field adding Q2 option.

**6A. Maintained test switch.** An auxiliary two position maintained test switch is located on the cabinet door. This is in addition to the standard test switch found on all MX100 models. When the auxiliary test switch is activated in the TEST position, it will simulate a Normal line failure. The transfer switch will automatically transfer the load to the Emergency position. When the test switch is returned to the AUTOMATIC position the transfer switch will restore the load to the Normal position. Should Emergency fail while ATS is in Emergency position the ATS will transfer back to Normal immediately, if Normal is available.

**C. Plant Exerciser.** Automatically starts generator for selected time intervals. Runs generator unloaded.

**C/D. Plant Exerciser.** Automatically starts generator to run unloaded, or simulate a power failure and starts generator to run under load.

**Q2. Connections for remote peak shave or area protection.** Includes bypass for immediate return to Normal if Emergency line fails and Normal is available.

**Z-NET100. Communication Capability.** The MX100 can be equipped with an optional network card that allows digital communication of ATS position, source availability, control timers and test mode. A test signal can also be initiated from a remote PC or annunciator panel. Communication is via one twisted pair of wires.

# User Settings

All user settings are adjustable on the back of the MX100 display. Figure 5 shows the MX100 user adjustments.

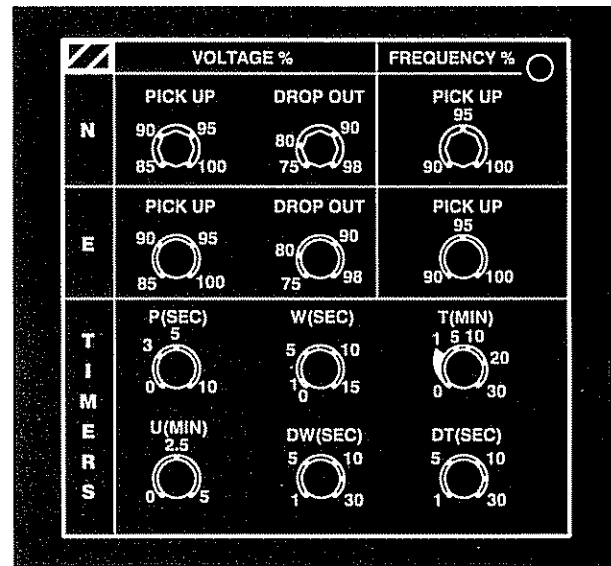

Figure 5 - Delayed Transition User Adjustments

## ▲ NOTICE

All adjustments are factory preset to values in the table below, unless otherwise specified by the user.

Factory Settings of Voltage, Frequency and Timer Adjustments	
Normal Pickup Voltage	90% Nominal Line Voltage
Normal Dropout Voltage	80% Nominal Line Voltage
Normal Pickup Frequency	90% Nominal Line Frequency
Emergency Pickup Voltage	90% Nominal Line Voltage
Emergency Dropout Voltage	80% Nominal Line Voltage
Emergency Pickup Frequency	95% Nominal Line Frequency
P Timer	3 seconds
W Timer	1 second
T Timer	30 minutes
U Timer	5 minutes
DW Timer *	5 seconds
DT Timer *	5 seconds
TA5 **	5 seconds
TA6 **	5 seconds

\* Delayed

\*\* Standard w/A6 or T3/W3

## Voltage and Frequency Pickup/Dropout Adjustments

**Normal Pickup Voltage %:** Pickup voltage is adjustable from 85 to 100% of nominal line voltage. Standard factory setting is 90%.

**Normal Dropout Voltage %:** The dropout voltage is adjustable from 75 to 98% of nominal line voltage. Standard factory setting is 80%. Dropout must be a minimum of 2% below Normal pickup voltage under all conditions. Note: The microprocessor will automatically set the Normal dropout voltage 2% below the Normal pickup voltage if it is not properly set by the user.

**Normal Pickup Frequency %:** The pickup frequency is adjustable from 90 to 100% of nominal line frequency. Standard factory setting is 90%.

**Emergency Pickup Voltage %:** The pickup voltage is adjustable 85 to 100% of nominal line voltage. The standard factory setting is 90%.

**Emergency Dropout Voltage %:** The dropout voltage is adjustable from 75 to 98% of nominal line voltage. Standard factory setting is 80%. Emergency dropout voltage must be a minimum of 2% below emergency pickup voltage under all conditions. Note: The microprocessor will automatically set the Emergency dropout voltage 2% below the Emergency pickup voltage if it is not properly set by the user.

**Emergency Pickup Frequency %:** The pickup frequency is adjustable from 90 to 100% of nominal line frequency. Dropout is fixed at 2 Hz below pickup. Dropout has a 5 second delay. Standard factory setting is 95%.

## Timer Adjustments

**P Timer** (delay to engine start). Time delay before engine start after Normal voltage failure: adjustable 0 to 10 seconds. P timer is designed to avoid engine starts on momentary Normal source failures. Standard factory setting is 3 seconds.

**W Timer** (delay to Emergency or delay to open Normal timer). Time delay before initiating transfer to Emergency: adjustable 0 to 15 seconds. Standard factory setting is 1 second. After the successful acquisition of correct Emergency voltage and frequency, the W timer function provides a time delay before initiating transfer to Emergency. This permits the Emergency source to stabilize. On completion of the time out, transfer to Emergency is initiated.

Transfer to Emergency is non-commit. This means that should the Normal voltage be restored before the timeout of the W timer, the ATS will remain in the Normal position and initiate the delay to engine stop timer.

# User Settings *(cont'd)*

**T Timer** (delay to Normal or delay to open Emergency). Time delay before initiating retransfer to Normal: adjustable 0 to 30 minutes. Standard factory setting is 30 minutes. On return of acceptable Normal voltage the time delay is initiated. T time delay ensures Normal source has stabilized before transferring to Normal position. On completion of the time out, transfer to Normal is initiated. Should Emergency power fail when the ATS is in the Emergency position, the T timer function will be bypassed when normal power is restored.

**U Timer** (delay engine stop). Time delay to engine stop, after retransfer to Normal, for purpose of cooling the engine after the load is removed: adjustable 0 to 5 minutes. Standard factory setting is 5 minutes.

**DW Timer** (time delay from Open position to Emergency position). Delayed Transition Transfer only: adjustable 0 to 60 seconds. Standard factory setting is 5 seconds. DW timer activates when the switch enters open position on a transfer from Normal to Emergency. After time out, the transfer to Emergency is complete.

**DT Timer** (time delay from Open position to Normal position). Delayed Transition Transfer only: adjustable 0 to 60 seconds. Standard factory setting is 5 seconds. DT timer activates when the switch enters the open position on transfer from Emergency to Normal. After time out, the transfer to Normal is complete.

**MX100, Standard Transition w/A6 or T3/W3**  
**(A6 = motor load disconnect circuit)**  
**(T3/W3 = elevator presignal circuit)**

**TA5** (presignal time delay to normal). Time delay is available only on standard transition ATSs specifically configured with the presignal circuit. Adjustable 0 to 60 seconds. Standard factory setting is 5 seconds.

**TA6** (presignal time delay to emergency). Time delay is available only on standard transition ATSs specifically configured with the presignal circuit. Adjustable 0 to 60 seconds. Standard factory setting is 5 seconds.

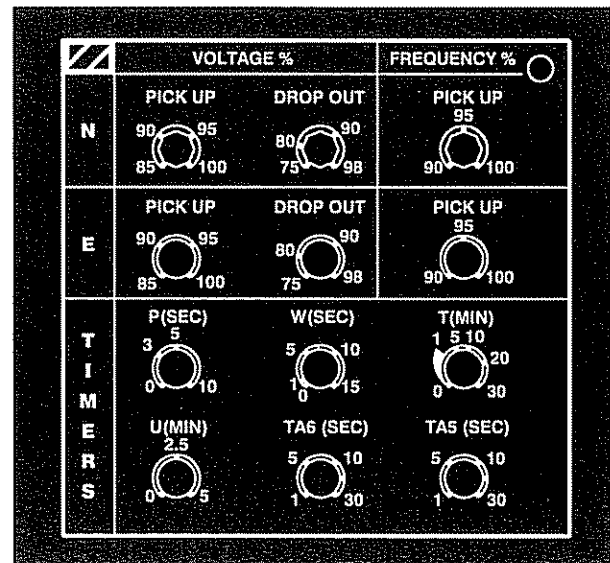

Figure 6 - Standard Transition w/A6 or T3/W3 User Adjustments

# Relay/Transformer Box (R/T Box)

Each MX100 microprocessor based ATS controller requires a relay/transformer box to apply line voltage to the ATS operator via coil control relays. Also required is a means to power the MX100 printed circuit board and a means to apply sensing voltage proportional to line voltage. This is accomplished by the relay transformer box. This method of switching operator voltage and applying power and sensing voltage to the printed circuit board isolates the MX100 from the line voltage, further protecting the controller from harmful line transients. Two versions of the R/T box exist depending on the type of ATS (standard transition or delayed transition).

The following layout drawings of the R/T box components (standard and delayed transition) include a bill of materials for replacement parts. Schematics are included to indicate proper wiring.

## Standard Transition

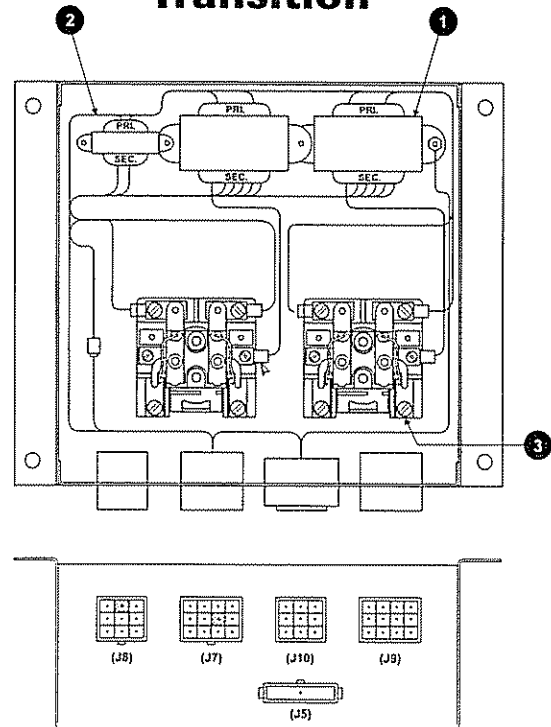

### Bill of Material

Item	Part No.	Description	Qty
1	See Chart	Transformer, 25VA	2
2	See Chart	Transformer, 1VA	1
3	K-1260	Coil Control Relay, 24V	2

### Transformer Usage

R/T Box Assembly Part No.	Primary Voltage at 50/60 Hz	1VA XFMR Part No.	25VA XFMR Part No.
50P-1005	120V	K-3216	K-3224
50P-1006	208-220V	K-3217	K-3225
50P-1007	230-240V	K-3218	K-3226
50P-1008	277V	K-3219	K-3227
50P-1009	380-400V	K-3220	K-3228
50P-1010	416-440V	K-3221	K-3229
50P-1011	460-480V	K-3222	K-3230
50P-1012	575-600V	K-3223	K-3231

# Relay/Transformer Box (R/T Box) *(cont'd)*

## Delayed Transition

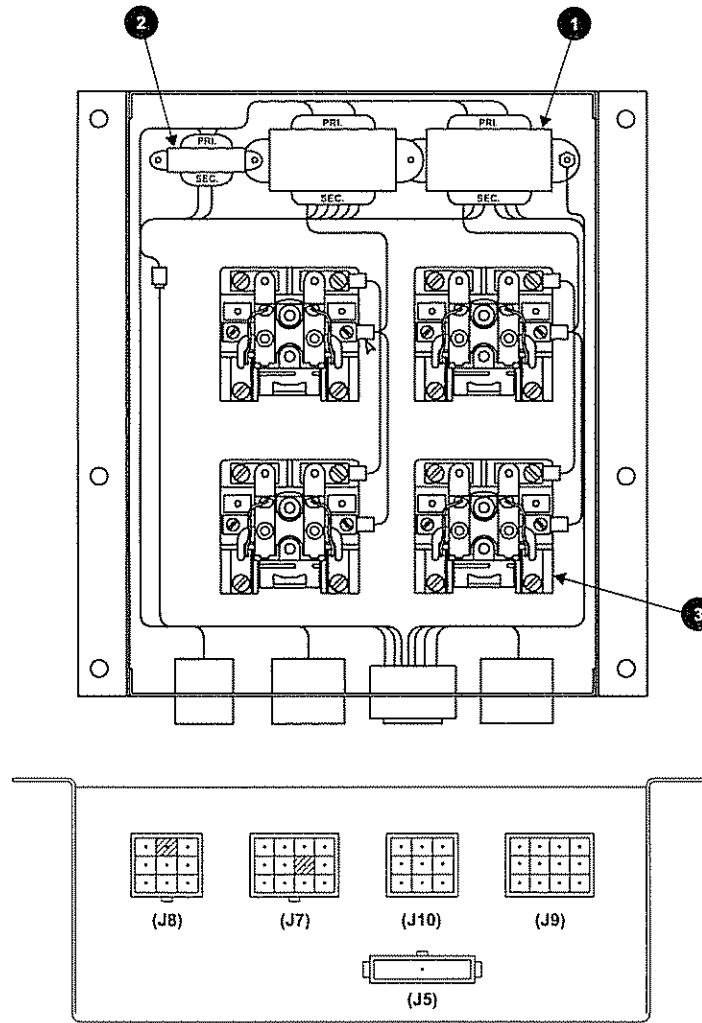

### Bill of Material

Item	Part No.	Description	Qty
1	See Chart	Transformer, 25VA	2
2	See Chart	Transformer, 1VA	1
3	K-1260	Coil Control Relay, 24V	4

### Transformer Usage

R/T Box Assembly Part No.	Primary Voltage at 50/60 Hz	1VA XFMR Part No.	25VA XFMR Part No.
50P-1013	120V	K-3216	K-3224
50P-1014	208-220V	K-3217	K-3225
50P-1015	230-240V	K-3218	K-3226
50P-1016	277V	K-3219	K-3227
50P-1017	380-400V	K-3220	K-3228
50P-1018	416-440V	K-3221	K-3229
50P-1019	460-480V	K-3222	K-3230
50P-1020	575-600V	K-3223	K-3231

# Relay/Transformer Box (R/T Box) *(cont'd)*

## Standard Transition R/T Box Schematic

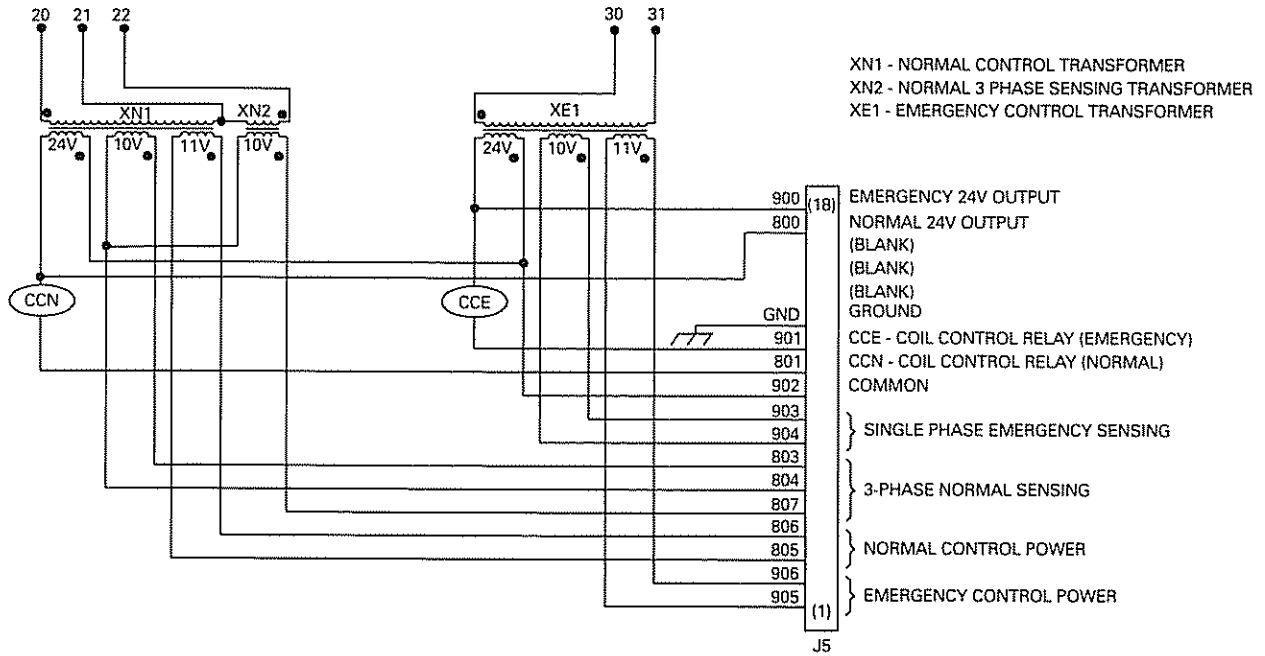

## Delayed Transition R/T Box Schematic

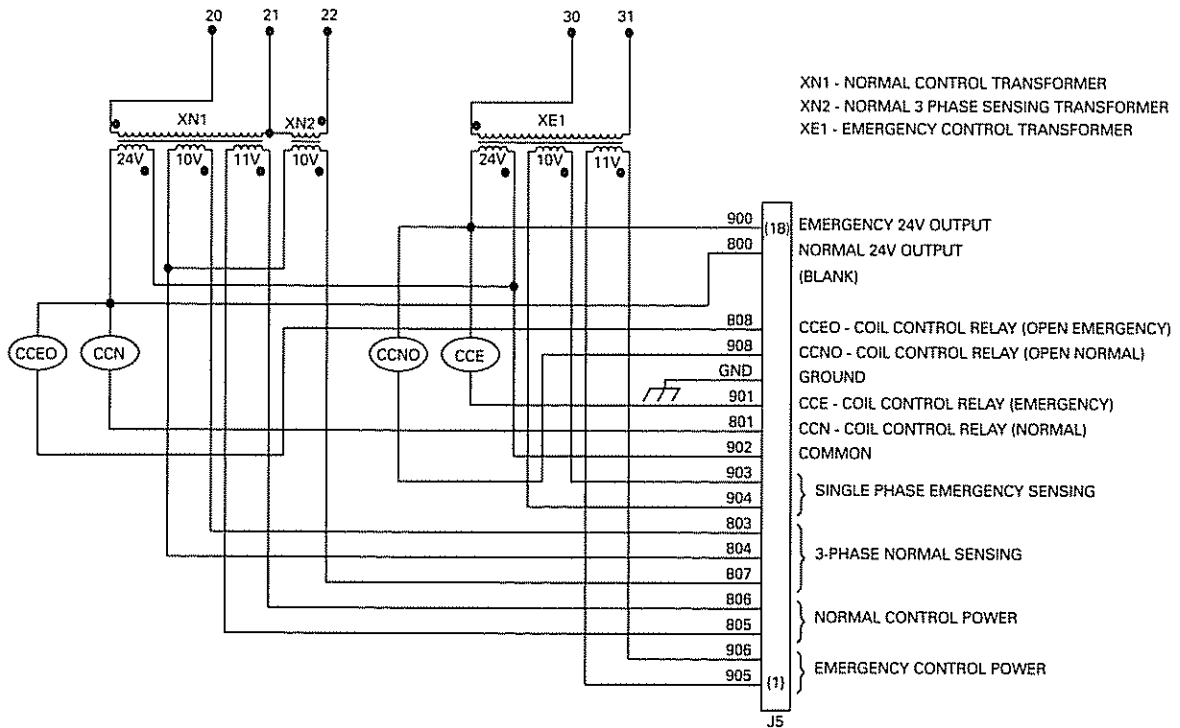

# Troubleshooting and Diagnostics

## ▲ DANGER

**HAZARDOUS VOLTAGES CAN CAUSE SEVERE INJURY OR DEATH.**

These charts may indicate problems that require authorized Zenith service personnel.  
Hazardous voltages may exist on termination plugs other than those that go into the MX100.

## General Troubleshooting

The following chart can be used to troubleshoot the ATS system. Diagnostics are indicated by one or more flashing position LED(s). Diagnostic troubleshooting charts follow this chart.

Symptom	Annunciation	Possible Cause(s)	Corrective Action
No engine start	EMERGENCY AVAILABLE LED off	Engine start wires not properly connected	Check engine start connections (Figure 1)
		Generator in OFF position	Place engine control switch in AUTO
No engine stop	DELAY TO ENGINE STOP LED on	U timing cycle not complete	Check U timer setting
	NORMAL AVAILABLE, NORMAL POSITION, and EMERGENCY AVAILABLE LEDs on	Engine start wires not properly connected	Check engine start connections (Figure 1)
Generator in MANUAL		Place engine control switch in AUTO	
ATS will not transfer to EMERGENCY	EMERGENCY AVAILABLE LED off	Emergency voltage or frequency not within settings	Check: engine start connections, generator breaker closed, generator output (compare to MX100 settings) and place engine control switch in AUTO
	All LEDs off	Power supply harness unplugged (18 pin connector on MX100)	Plug in harness
	EMERGENCY AVAILABLE LED on	ZTC models only - verify zero volts DC from pin 5 to pin 6 of 6 pin plug on MX100	If 5V measured, ZTC is tripped; refer to Power Panel Manual (51R-1000) for ZTC instructions
ATS will not transfer to NORMAL	NORMAL AVAILABLE LED off	Normal voltage or frequency not within acceptable parameters	Check: normal voltage within MX100 settings; verify Normal breaker source breaker is closed
		All LEDs off	Power supply harness unplugged (18 pin connector on MX100)
	NORMAL AVAILABLE LED on	ZTC models only - verify zero volts DC from pin 5 to pin 6 of 6 pin plug on MX100	If 5V measured, ZTC is tripped; refer to Power Panel Manual (51R-1000) for ZTC instructions
Improper LED annunciation	Neither source available LEDs illuminate, position LED only	MX100 PC board may be configured for wrong frequency (60 Hz vs. 50 Hz)	1. Verify source voltage and frequency 2. Consult Zenith Controls for information to reconfigure hardware
	NORMAL and/or EMERGENCY AVAILABLE LEDs on when frequency is below the present pick up value	MX100 PC board may be configured for wrong frequency (60 Hz vs. 50 Hz)	1. Verify source voltage and frequency 2. Consult Zenith Controls for information to reconfigure hardware

# Troubleshooting and Diagnostics *(cont'd)*

## Diagnostic Annunciation

The MX100 controller incorporates diagnostics that allows ease of troubleshooting. Diagnostic annunciations are flashing position LEDs. The symptoms that the diagnostic annunciation indicate include inhibiting transfer or incorrect transfer sequence. A more general troubleshooting chart that addresses system problems precedes these charts.

### **▲ DANGER**

**HAZARDOUS VOLTAGES CAN CAUSE SEVERE INJURY OR DEATH.**

These charts may indicate problems that require authorized Zenith service personnel.

Hazardous voltages may exist on termination plugs other than those that go into the MX100.

## Standard Transition ATS *(Two Position ATS—Normal and Emergency)* *(Not for Standard Transition w/A6)*

### **▲ WARNING**

If limit switch plug is disconnected or reconnected and power is available, the switch may transfer.

Use caution when servicing.

Symptom	Annunciation	Possible Cause(s)	Corrective Action
ATS will not transfer out	Flashing NORMAL POSITION LED	Solenoid circuit	Contact authorized Zenith service representative
ATS will not transfer out	Flashing EMERGENCY POSITION LED	Solenoid circuit	Contact authorized Zenith service representative
ATS will not transfer; ATS is not in a defined position as indicated by the limit switch contact (no SN or SE limit switch input)	Flashing NORMAL POSITION and EMERGENCY POSITION LEDs	1. Limit switch plugs not connected 2. Limit switches not within adjustment	1. Connect all plugs to the MX100 2. Contact authorized Zenith service representative

# Troubleshooting and Diagnostics *(cont'd)*

## Delayed Transition ATS

(Three Position ATS—Normal, Open and Emergency)

### ▲ WARNING

If limit switch plug is disconnected or reconnected and power is available, the switch may transfer.

Use caution when servicing.

Symptom	Annunciation	Possible Cause(s)	Corrective Action
ATS will not transfer out of Normal	Flashing NORMAL POSITION LED	<ol style="list-style-type: none"> <li>ZTC in manual mode (ZTC models only)</li> <li>Solenoid circuit</li> </ol>	<ol style="list-style-type: none"> <li>Put ZTC in AUTO (ref. ZTC Power Panel Manual 51R-1000) disconnect and reconnect MX100 18 pin plug</li> <li>Contact authorized Zenith</li> </ol>
ATS will not transfer out of Emergency	Flashing EMERGENCY POSITION LED	<ol style="list-style-type: none"> <li>ZTC in manual mode (ZTC models only)</li> <li>Solenoid circuit</li> </ol>	<ol style="list-style-type: none"> <li>Put ZTC in AUTO (ref. ZTC Power Panel Manual 51R-1000) disconnect and reconnect MX100 18 pin plug</li> <li>Contact authorized Zenith</li> </ol>
ATS will not transfer out of Open position	Flashing OPEN POSITION LED	<ol style="list-style-type: none"> <li>ZTC in manual mode (ZTC models only)</li> <li>Solenoid circuit</li> </ol>	<ol style="list-style-type: none"> <li>Put ZTC in AUTO (ref. ZTC Power Panel Manual 51R-1000) disconnect and reconnect MX100 18 pin plug</li> <li>Contact authorized Zenith</li> </ol>
ATS is not in a defined position as indicated by the limit switch contacts (no SN or SNO limit)	Flashing NORMAL POSITION and OPEN POSITION LEDs	Limit switches not registered as opened or closed	Contact authorized Zenith service representative
ATS is not in a defined position as indicated by the limit switch contacts (no SN or SEO limit switch)	Flashing EMERGENCY POSITION and OPEN POSITION LEDs	Limit switches not registered as opened or closed	Contact authorized Zenith service representative
ATS is not in a defined position as indicated by the limit switch contacts (no SN, SE, SNO, or SEO)	Flashing NORMAL POSITION, OPEN POSITION and EMERGENCY POSITION LEDs	<ol style="list-style-type: none"> <li>Limit switch plugs not connected</li> <li>Limit switches not registered as opened or closed</li> </ol>	Connect all plugs to the MX100

# Troubleshooting and Diagnostics *(cont'd)*

## Standard Transition ATS (with A6)

### ▲ WARNING

If limit switch plug is disconnected or reconnected and power is available, the switch may transfer.

Use caution when servicing.

Symptom	Annunciation	Possible Cause(s)	Corrective Action
ATS will not transfer out of Normal; motor load still connected	Flashing NORMAL POSITION LED	Motor load disconnect relay is <u>not</u> latching	Check connections to RA6 relay
ATS will not transfer out of Emergency; motor load still connected	Flashing EMERGENCY POSITION LED	Motor load disconnect relay <u>is</u> latched	Check connections to RA6 relay
ATS will not transfer after motor load disconnect operated	Flashing MOTOR CONTROL OFF LED	Solenoid circuit	Contact authorized Zenith service representative
ATS is not in a defined position as indicated by the limit switch contacts (no SN or RA6 limit	Flashing NORMAL POSITION and MOTOR CONTROL OFF LEDs	Limit switches not registered as closed or RA6 contact is not registered	Contact authorized Zenith service representative
ATS is not in a defined position as indicated by the limit switch contacts (no SE or RA6 limit switch	Flashing EMERGENCY POSITION and MOTOR CONTROL OFF LEDs	Limit switches not registered as closed or RA6 contact is not registered	Contact authorized Zenith service representative
ATS is not in a defined position as indicated by the limit switch contacts (no SN, SE, SNO, or SEO	Flashing NORMAL POSITION, OPEN POSITION and EMERGENCY POSITION LEDs	1. Limit switch plugs not connected 2. Limit switches not registered as opened or closed	Connect all plugs to the MX100





830 West 40<sup>th</sup> Street  
Chicago, IL 60609 USA

Phone: 773 247-6400  
Fax: 773 247-7805

*[www.zenithcontrols.com](http://www.zenithcontrols.com)*  
*E-Mail: [zenith@zenithcontrols.com](mailto:zenith@zenithcontrols.com)*