



GE Zenith Controls

**ZTS/ZTSD Series Transfer Switches
40-4000 Amps**



Authorized Service

For GE parts and service, call: 773 299-6600

Table of Contents

	Page		Page
Introduction	ii	Controls Power Supply (CPS)	21
Safety	1	Schematics, Standard & Delay	22
Equipment Inspection and Storage	1	Troubleshooting & Diagnostics	23
Final Equipment Inspection	1	Maintenance and Testing	24
Mounting	1	Inspection and Cleaning	24
Installation	2	Servicing	24
Power Connections	2	Testing	24
Engine Start Control Connections	2-3	Replacement Parts	25
Initial Energization	3-4	Standard Transition	25
Control Connections	5	40-200 Amps	25
Entelli-Switch 250 Microprocessor Controller	6	225-400 Amps	26
Overview	6	600-1200 Amps	27
LCD & Keypad	7	1600-3000 Amps	28
User Setting for Voltage & Frequency	8	4000 Amps	29
Accessory Group Packages	9	Delayed Transition	30
Accessory Definitions	10-13	40-400 Amps	30
How to Set the System Clock	13	600-1200 Amps	31
CDT One Event Timer Exerciser	14	1600-3000 Amps	32
CDP Clock Exerciser	15	4000 Amps	33
User Setup - CFG Menu	16	ZTSH/ZTSDH/ZTSDL/ZTSHL/ZTSDHL	34
User Setup - SET Menu	17	Standard Control Panel Layout (SSRCP)	34
User Setup - System Info	18	Panel Mount Control Relays	34
Testing	19	Sequence of Operation	35
ATS Testing	19	Adjustments and Settings	36
Standard Transition	19	Solid State Timers	36
Delayed Transition	19	Voltage/Frequency Sensor (VSFM)	36
Sequence of Operation	20	Solid State Phase Relay	36
Standard Transition	20		
Delayed Transition	20		

Introduction

GE Zenith Transfer Switches are used to provide a continuous source of power for lighting and other critical loads by automatically transferring from source 1 power to source 2 power in the event that source 1 voltage falls below preset limits.

Voltage sensing and system control is performed via a state-of-the-art microcontroller located on the cabinet door. It is designed to give highly accurate control of the transfer switch system.

All GE Zenith transfer switches are designed for use on emergency or standby systems, and are rated for total system or motor loads. Transfer switches are UL Listed under Standard 1008 and CSA Certified under Standard C22.2 No. 178 and IEC Listed under Standard 947.

NOTES:

A protective device such as a molded case circuit breaker or fused disconnect switch MUST be installed on both sources of incoming power for circuit protection and as a disconnection device.

All references made within this manual about the term "S1" or "Source 1" relate to a Normal Power Source.

All references made about the term "S2" or "Source 2" relate to an Emergency or Alternative Power Source.

Safety

⚠ DANGER ⚠

HAZARDOUS VOLTAGE (Can Cause Severe Injury or Death)

Turn OFF all power before installation, adjustment, or removal of transfer switch or any of its components.

The safe operation of your switch is GE Zenith's focus. The proper storage, installation, operation and maintenance will help increase the life of the switch.

⚠ CAUTION ⚠

Due to hazardous voltage and current, GE Zenith recommends that a GE Zenith Certified technician or a qualified electrician must perform the installation and maintenance of the switch.

Equipment Inspection and Storage

Once you have received the transfer switch, inspect it for any damage. This includes damage to the enclosure, power panel, control panel and wiring harness. If any damage is found or suspected, file a claim as soon as possible with the carrier and notify the nearest GE Zenith representative.

Before installation, if it is necessary, store the transfer switch in a clean dry place, protected from dirt and water. Provide ample air circulation and heat, if necessary, to prevent condensation.

Storage Temperature	Operating Temperature (Ambient):	Humidity
-30°C to +75°C (-22°F to +167°F)	40-400 AMP (molded shell) 40-4000 AMP (all other frame and panel types)	5% to 95% (non-condensing)
	-20°C to +60°C (-4°F to +140°F)	

Final Equipment Inspection

Prior to energizing the transfer switch:

1. Remove any debris incurred, with a vacuum, due to shipment or installation.

⚠ WARNING ⚠

Do not use a blower since debris may become lodged in the electrical and mechanical components and cause damage.

2. Verify that all cabled connections are correct and that phase rotation of both sources match.
3. Check engine start connections.
4. Verify the correct connection of all control wires.
5. Check settings of all timers and adjust as necessary.
6. Adjust any optional accessories as required.
7. Check the lug torque values of the power connections.

NOTE: Lug torque values are specified in table 2 on pg.2.

8. Make sure that all covers and barriers are installed and properly fastened.

NOTE: Power panels ship from GE Zenith in Source 1 Position.

Each GE Zenith transfer switch is factory wired and tested. A complete information package is furnished with each switch which includes:

- a. Sequence of operation.
- b. Description and operation of all accessories supplied.
- c. Power panel connection diagram and schematic.
- d. Description and identification of all customer field connections.

Installation of GE Zenith transfer switches includes:

- a. Mounting the transfer switch cabinet.
- b. Connection of Source 1, Source 2, and Load cables or bus bars.
- c. Connection of external control circuits as required.

Mounting

Adequate lifting means must be used to mount the transfer switch into place. The recommended method for moving the transfer switch using the lifting eyes, where supplied, and a spreader bar is illustrated in *Figure 1*. Enough room should be allowed to open the cabinet doors fully for inspection and servicing of the switch per NEC and local codes.

⚠ CAUTION ⚠

Before drilling conduit entry holes or any accessory mounting holes, cover and protect the switch and control panel to prevent dirt and metal fragments from entering the mechanical and electrical components.

Failure to do so may result in damage and malfunction of the switch.

Installation

⚠ DANGER ⚠

HAZARDOUS VOLTAGE (Can Cause Severe Injury or Death)

Turn OFF all power before installation, adjustment, or removal of transfer switch or any of its components.

Power Connections

GE Zenith transfer switches are supplied with UL listed solderless screw type terminals as standard for the Source 1, Source 2 and Load power connections.

Table 1 lists the number and sizes of cable lugs supplied as standard for each switch amp rating.

Connect the Source 1, Source 2, and Load conductors to the clearly marked terminals on the transfer switch. Remove surface oxides from cables by cleaning with a wire brush. Verify that all connections are correct before tightening the lugs. All cable lug connections must be tightened to the proper torque values as shown in Table 2.

NOTE: Do not run cables or wiring behind front-connected transfer switches.

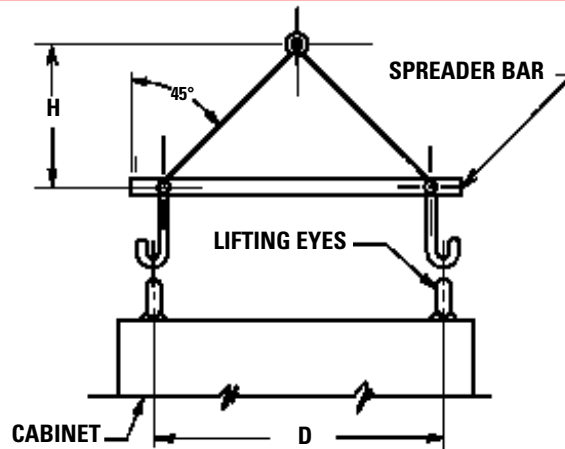

Figure 1

NOTE: When lifting the switch using a spreader bar, height H must be equal to half of distance D.

Power Connections: Screw Type Terminals for External Power Connections

Switch Size (Amps)	Source 1, Source 2 & Load Terminals		Neutral Bar (When Required)	
	Cable Per Pole	Range of Wire Sizes	No. of Cables	Range of Wire Sizes
40	1	#8 AWG to 1/0	3	#8 AWG to 1/0
80	1	#8 AWG to 1/0	3	#8 AWG to 1/0
100	1	#8 AWG to 1/0	3	#8 AWG to 1/0
150	1	#8 AWG to 3/0	3	#8 AWG to 300 MCM
200, 225, 2500	1	#6 AWG to 250 MCM	3	#6 AWG to 300 MCM
260, 300*, 400	1	#4 AWG to 600 MCM	3	#4 AWG to 300 MCM
600	2	#2 AWG to 600 MCM	8	#2 AWG to 600 MCM
800, 1000, 1200	4	#2 AWG to 600 MCM	12	#2 AWG to 600 MCM
1600, 2000 2600, 3000, 4000	Line, Load and Neutral terminals are located in the rear of switch and arranged for bus bar locations			

Table 1

Engine Start Control Connections

Engine-start control wires connect to control terminals beside the Entelli-Switch 250. Engine start terminals are indicated by a schematic symbol (the symbol indicates the contact state for a de-energized normal source).

Figure 2 shows the engine-start contacts.

Make all other necessary control connections to the control panel terminal blocks per the schematics supplied with the ATS.

NOTE: All control wires (18-12 AWG) must be torqued to 19 in/lbs.

Tightening Torque for Lugs

Socket Size Across Flats	Torque	
	Lb. - In.	Lb. - Ft.
1/8	45	4
5/32	100	8
3/16	120	10
7/32	150	12
1/4	200	17
5/16	275	23
3/8	375	31
1/2	500	42
9/16	600	50

Table 2

⚠ DANGER ⚠

HAZARDOUS VOLTAGE (Can Cause Severe Injury or Death)

Turn OFF all power before installation, adjustment, or removal of transfer switch or any of its components.

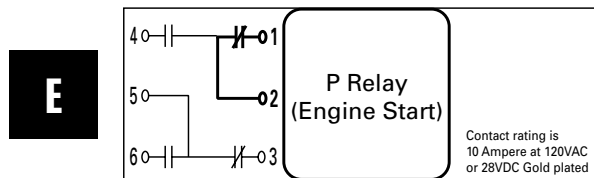

Figure 2

Engine Start Control Connections

The engine-start terminals are clearly identified by a label on the microcontroller backplate. In the case of manual transfer switches, or in other applications not requiring the microprocessor, clearly marked terminal blocks are provided in the upper left corner of the control panel for the engine start control wires.

Transfer Switch. Figure 5 (pg.5) shows location of engine start connections for Automatic Transfer Switch.

Terminals for field connections to the A3 Source 2 auxiliary contacts and the A4 Normal auxiliary contacts are also provided. These terminals are clearly marked and appear on the side of the power panel. On 400 amp metal frame units these terminals appear on the bracket above the operator handle.

Initial Energization

Before proceeding, refer to the information package supplied with the ATS and read and understand the information on all accessories provided.

1. Unlock the enclosure.
2. Open the enclosure.
3. Verify the correct system voltage.

NOTE: The equipment rating nameplate on the transfer switch lists the voltage. See Figure 3.

4. Close Source 1 circuit breaker.

NOTE: The controller will illuminate Source 1 Available LED if proper voltage is sensed.

5. Verify the phase to phase voltages at Source 1 line terminals.
6. Close Source 2 source circuit breaker.
7. Start the generator's engine.

NOTE: The controller will illuminate Source 2 Available LED when preset voltage and frequency levels are reached.

8. Verify the phase to phase voltages at Source 1 line terminals.
9. Verify that the phase rotation of Source 1 is the same as the phase rotation of Source 2.
10. Shut down the generator's engine.
11. Place the starting control in the Automatic position.
12. Complete the visual inspection of the transfer switch.
13. Close the enclosure.
14. Lock the enclosure.

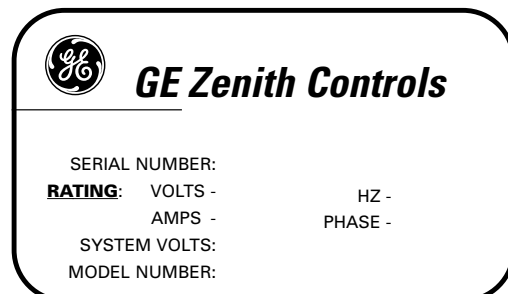
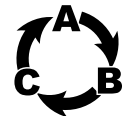

Figure 3

⚠ CAUTIONS ⚠

Certain accessories, per specific schematics, can inhibit automatic transfer. Engine Gen-Set could start when engine control wires are attached.

Installation *(cont'd)*

Initial Energization *(cont'd)*

After all options and accessories are checked and verified, follow these steps to set up the ATS. Refer to Entelli-Switch 250 display *Figure 4*. The annunciation LEDs illuminate to indicate (1) source availability, (2) ATS position, and (3) Entelli-Switch 250 control function (timing).

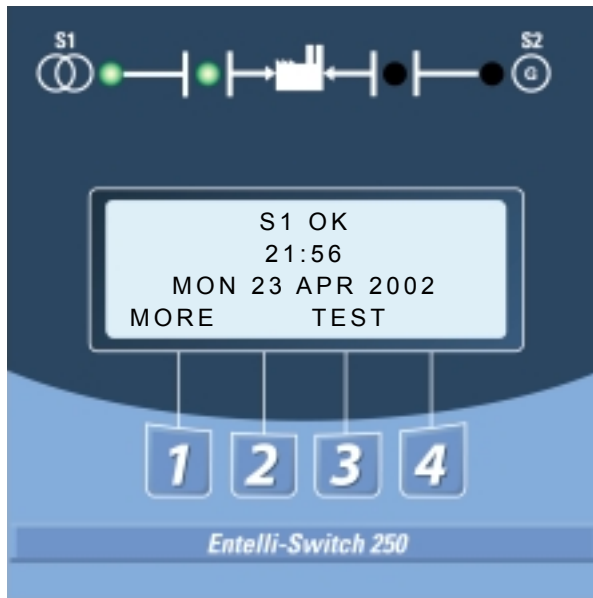

Figure 4 – LCD and keypad

1. Unlock the enclosure.
2. Open the enclosure.
3. Place the Disconnect Switch in the Inhibit.

NOTE: This step is only performed if the “DS” Option was purchased.

4. Close the external (up-stream) Source 1 circuit breaker.

NOTES: Source 1 Available and Source 1 Position LED’s will illuminate.

If Source 1 Available LED does not illuminate, verify that Source 1 Voltage is above the preset restore value.

The Gen-Set will start and run while Source 2 stop Delay Timer is timing.

5. Close the External (up-stream) Source 2 line circuit breaker.
6. Start the engine generator in MANUAL mode.

NOTE: When the voltage and frequency reach preset values, the Source 2 Available LED will illuminate.

7. Verify the phase to phase voltages at Source 2 line terminals.
8. Verify that the phase rotation of Source 2 is the same as the phase rotation of Source 1.
9. Shut down the generator's engine. (Place in Automatic Mode.)

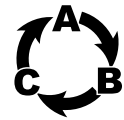

NOTE: Source 2 Available LED will turn off.

NOTE: The engine generator will continue to run for the duration of Source 2 Stop Delay Timer.

10. Place the disconnect switch to ENABLE.
11. Complete the visual inspection of the transfer switch.
12. Close the enclosure.
13. Lock the enclosure.

▲ WARNING ▲

When performing a hi-pot or dielectric test on the power section, DISCONNECT the control panel plugs from the microprocessor to avoid potential damage.

⚠ DANGER ⚠

HAZARDOUS VOLTAGE (Can Cause Severe Injury or Death)

Turn OFF all power before installation, adjustment, or removal of transfer switch or any of its components.

Control Connections

Figure 5

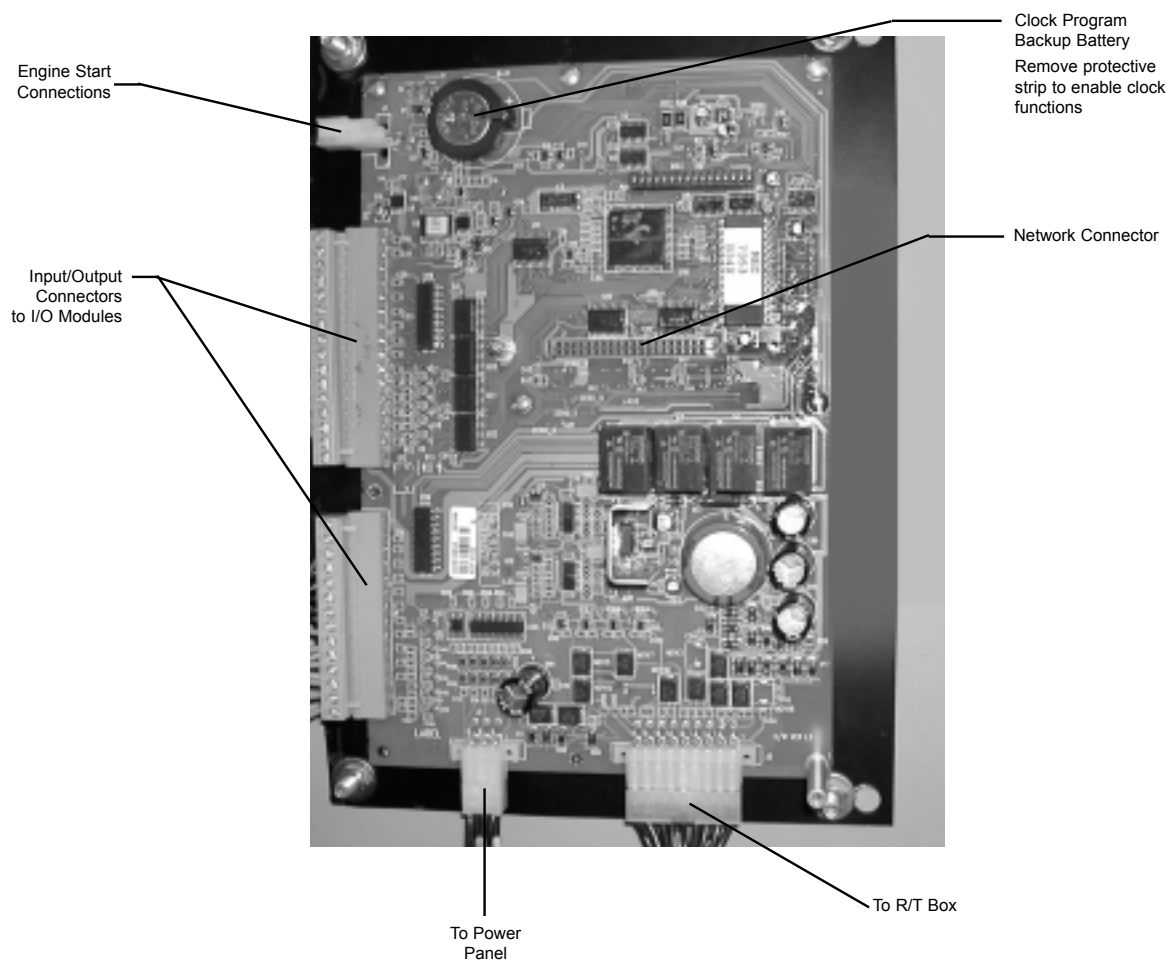

A complete information package is furnished with each transfer switch including a complete connection diagram and schematic which details all necessary control circuit field connections.

The engine start control wires connect to the engine start relay terminals located to the left of the microprocessor. Figure 5 shows the location of these terminals.

The terminals are clearly identified by a label on the microcontroller backplate. In the case of manual transfer switches, or in other applications not requiring the microprocessor, clearly marked terminal blocks are provided in the upper left corner of the control panel for the engine start control wires.

Entelli-Switch 250 Controller

Entelli-Switch 250 Controller

Consists of two major assemblies:

I. The **Microprocessor** contains the following:

- A. Entelli-Switch 250 Board - Customer Input and Output (I/O) for system interface. Located on the left hand side of the back of the unit (see figure 6)
 1. I/O accessories that can be found here are:
 - a. Engine start relay P output
 - b. Pre-Signal to transfer T3, W3 and UMD output (optional)
 - c. Transfer Inhibit Q3 and Q7 input (optional)
 - d. Remote test Q2 input (optional)
 - e. Network interface ZNET input/output (optional)
- B. LCD and Keypad located on the exterior of the door (see figure 7)
 1. User accessibility to the following:
 - a. LED indication of source availability
 - b. LED indication of transfer switch position
 - c. LCD screen indicates:
 - (1) timer count down (numeric)
 - (2) event reporting (text)
 - d. Keypad provides user interface to:
[in conjunction with LCD screen]
 - (1) Setting sensors and timers
 - (2) Configuring logic accessories

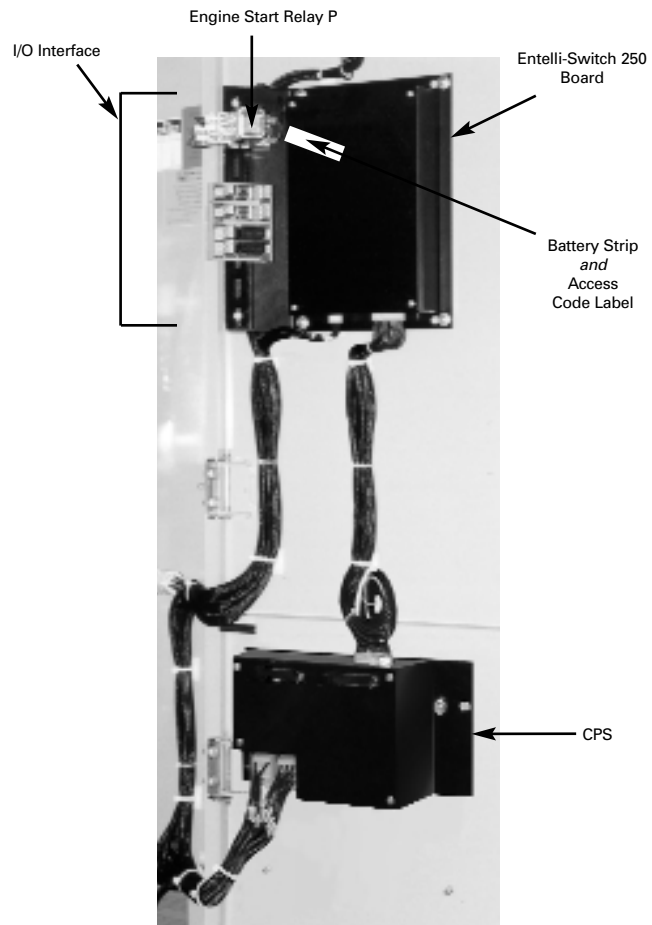

Figure 6

II. The **Controls Power Supply (CPS)**

Contains transformers which drop line voltage to control level for controller input and SCR inputs (see figure 6).

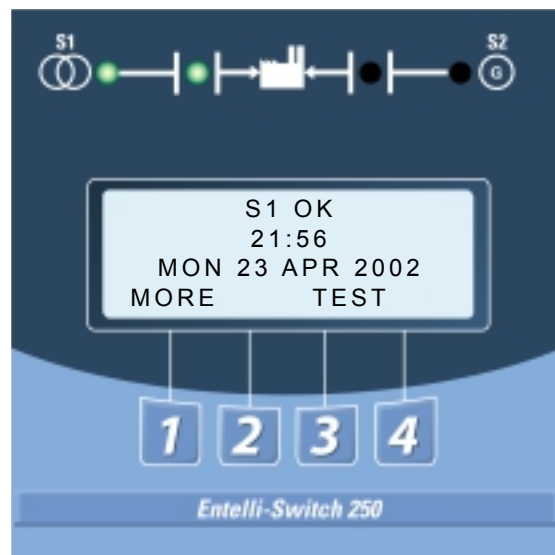

Figure 7

Entelli-Switch 250 Controller *(cont'd)*

LCD & Keypad

These options are accessible through the LCD and keypad (see figure below). To become familiar with the options loaded into a particular unit, scrolling through the SET and CFG menu will show the descriptions of the options (see pages 16-17). These menus are the very same menus that are used to access the setting and/or configuration of these options. The SET (setting) menu is primarily used to show or change, time and voltage settings. The CFG menu is primarily used to turn an option on or off. When scrolling through these menus,

no changes can be made without entry of the access code. The factory set six-digit access code is located on a white label on the back of the unit (see figure 10 pgs. 16-18).

The Entelli-Switch 250 has many logic options. Each controller is downloaded with options at the time of manufacture. The collection of options that any one controller has is specified at the time of order placement. The following pages include all the options that can reside in the controller. Not all units include all options.

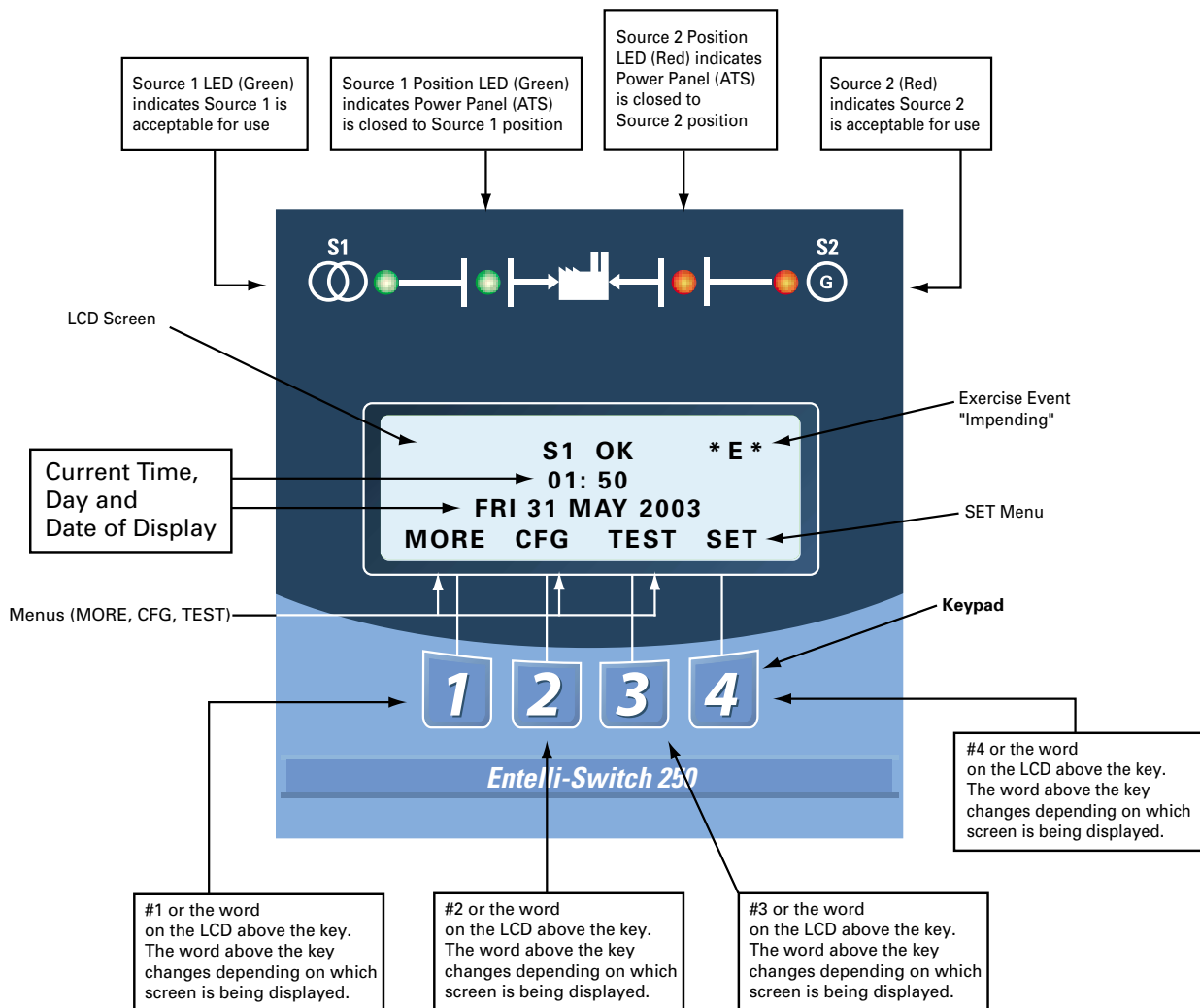

Figure 8

User Setting for Voltage & Frequency

Standard 3-Phase Sensing on 3 and 4 Pole Units

Source 1

Under Voltage "Restore"

Factory Default: 90%

This adjustment determines the minimum acceptable voltage required to transfer to Source 1.

Adjust via the SET menu. Range is 85% to 100% in 1% increments (see page 17).

Once satisfied, the T timer will begin timing to transfer to Source 1.

Under Voltage "Fail"

Factory Default: 80%

This adjustment determines the low voltage threshold. Adjust via the SET menu. Range is 75% to 98% in 1% increments (see page 17).

"Fail" must be a minimum of 2 % below "Restore" setting. Once voltage falls below threshold, P timer begins timing to signal Source 2 Generator to start.

Under Frequency "Restore"

Factory Default: 95%

This adjustment determines the minimum acceptable frequency required to transfer to Source 1.

Adjust via the SET menu. Range is 90% to 100% in 1% increments (see page 17).

Once satisfied, the T timer will begin timing to transfer to Source 1.

Under Frequency "Fail"

Factory Default: 90%, (5 seconds minimum).

This adjustment determines the low frequency threshold. Adjust via the SET menu. Range is 88% to 98% in 1% increments (see page 17).

"Fail" must be a minimum of 2 % below "Restore" setting. Once satisfied, the T timer will begin timing to transfer to Source 1.

Over Frequency "Restore"

Factory Default: 102%

This adjustment determines the minimum acceptable Over Frequency threshold at which the transfer switch is allowed to re-transfer to Source 1.

Adjust via the SET menu. Range is 102% to 104% in 1% increments (see page 17). "Restore" must be a minimum of 1% below "Fail" setting.

Over Frequency "Fail"

Factory Default: 105%

This adjustment determines the maximum acceptable Over Frequency.

Adjust via the SET menu. Range is 103% to 105% in 1% increments (see page 17). Once exceeded, the P timer begins timing to signal the generator to start.

Source 2

Under Voltage "Restore"

Factory Default: 90%

This adjustment determines the minimum acceptable voltage required to transfer to Source 2.

Adjust via the SET menu. Range is 85% to 100% in 1% increments (see page 17).

Once satisfied, the W timer will begin timing to transfer to Source 2.

Under Voltage "Fail"

Factory Default: 80%

This adjustment determines the low voltage threshold.

Adjust via the SET menu. Range is 75% to 98% in 1% increments (see page 17).

"Fail" must be a minimum of 2 % below "Restore" setting. Once voltage falls below threshold, T timer will be bypassed to expedite the transfer to Source 1.

Over Voltage "Fail"

Factory Default: 110%

This adjustment determines the maximum acceptable Over Voltage. Adjust via the SET menu. Range is 105% to 110% in 1% increments (see page 17).

Once exceeded, the T timer will be bypassed to expedite the transfer to Source 1.

Over Voltage "Restore"

Factory Default: 105%

This adjustment determines the minimum acceptable Over Voltage threshold at which the transfer switch is allowed to transfer to Source 2.

Adjust via the SET menu. Range is 103% to 105% in 1% increments (see page 17).

"Restore" must be a minimum of 2% below "Fail" setting.

Under Frequency "Restore"

Factory Default: 95%

This adjustment determines the minimum acceptable frequency required to transfer to Source 2.

Adjust via the SET menu. Range is 90% to 100% in 1% increments (see page 17).

Once satisfied, the W timer will begin timing to transfer to Source 2.

Under Frequency "Fail"

Factory Default: 90%, (5 seconds minimum).

This adjustment determines the low frequency threshold. Adjust via the SET menu. Range is 88% to 98% in 1% increments (see page 17).

"Fail" must be a minimum of 2 % below "Restore" setting. Once satisfied, the W timer will begin timing to transfer to Source 2.

Over Frequency "Fail"

Factory Default: 105%

This adjustment determines the maximum acceptable Over Frequency. Adjust via the SET menu. Range is 103% to 105% in 1% increments (see page 17).

Once exceeded, the T timer will be bypassed to expedite the transfer to Source 1.

Over Frequency "Restore"

Factory Default: 102%

This adjustment determines the minimum acceptable Over Frequency threshold at which the transfer switch is allowed to re-transfer to Source 2.

Adjust via the SET menu. Range is 102% to 104% in 1% increments (see page 17).

"Restore" must be a minimum of 1% below "Fail" setting.

Accessory Group Packages

Table 3

Accessories	Group Packages					
	STDS	EXES	CONS	SENS	SPES	PSGS
6P	●	●	●	●	●	●
A1	○	●	●	●	●	●
A1E	○	●	●	●	●	●
A3	●	②	②	②	②	③
A4	●	②	②	②	②	③
Calibrate	●	●	●	●	●	●
CDT	●					
CDP		●	●	●	●	●
**DS	●	●	●	●	●	●
*DT	●	●	●	●	●	●
*DW	●	●	●	●	●	●
E	●	●	●	●	●	●
EL/P	●	●	●	●	●	●
K/P	●	●	●	●	●	●
L1	●	●	●	●	●	●
L2	●	●	●	●	●	●
L3	●	●	●	●	●	●
L4	●	●	●	●	●	●
*LN	●	●	●	●	●	●
P1	●	●	●	●	●	●
Q2	○	●	●	●	●	●
Q3	○	○	●	○	●	●
Q7	○	○	●	●	●	●
R1-1	○	○	○	●	●	●
R1-3	○	○	○	●	●	●
R15	○	○	○	○	○	●
*R15D	○	○	○	○	○	●
R16	○	●	●	●	●	●
R50	●	●	●	●	●	●
S5P	◐	◐	◐		●	
S12P	◐	◐	◐	●		●
S13P	●	●	●	●	●	●
T	●	●	●	●	●	●
T3/W3	②	②	②	②	②	②
U	●	●	●	●	●	●
UMD	②	②	②	②	②	②
VI	●	●	●	●	●	●
W	●	●	●	●	●	●
YEN	●	●	●	●	●	●

- Standard Accessory included in the group package.
- Optional Accessory not included but can be added to group package.
- ◐ Optional Accessory. Can not be used with accessory having the same symbol.
- N/A
- ② Denotes an Accessory with 2 circuits as a standard.
- ③ Denotes an Accessory with 3 circuits as a standard.
- * Delayed Transition Units Only.
- ** Optional for 40-400 Amp

Accessory Definitions

6P

Test Switch, Momentary

6A

Test Switch, Maintained Auto/Momentary Test

6AP

Test Switch, Maintained/Momentary utilizing keypad

6B

Test Switch, Maintained - Auto / Momentary - Test, Key Operated

6C

Test Switch, Maintained - Auto / Maintained - Test, Key Operated

A1

Auxiliary Contact, operates on Source 1 line failure.

A1E

Auxiliary Contact, operates on Source 2 line failure.

A3

Auxiliary Contact: Closed in emergency (Source 2) Additional Available (10 max.) and need to be specified.

A4

Auxiliary Contact: Closed in normal (Source 1) Additional Available (10 max.) and need to be specified.

A62

Sequential Universal Motor Load Disconnect Circuit. Normally closed auxiliary contacts for motor loads. Open 0-60 seconds prior to transfer, after transfer, or both in either direction then re-close in timed sequence after transfer.

AB3

Auxiliary Contact: Closed in bypass emergency (Source 2) (S.P.D.T.) (Standard up to 400 Amp) Additional Available (10 max.) and need to be specified.

AB4

Auxiliary Contact: Closed in bypass normal (Source 1) (S.P.D.T.) (Standard up to 400 Amp) Additional Available (10 max.) and need to be specified.

B9

Battery charger connections.

Calibrate

While monitoring the actual Phase to Phase voltage levels and Frequency with a calibrated test equipment, the Phase to Phase voltage sensing and Frequency can be adjusted accordingly. Calibration capabilities are available for Frequency and AB, BC, CA Phase to Phase voltage for both Sources. Adjust via SET menu (see page 18)

CDP

Clock Exerciser Load/ No Load: Allows the Generator to start and run unloaded or to simulate a power failure, start Generator and run under load. Can be configured by end user for 1, 7, 14, 28, 365 day cycle. (See page 16)

CDT

Load or NO-Load. One event exerciser with adjustable Engine exercise timer. Exercise duration can be set between 5 and 60 minutes in 1 minute increments. Can be configured to run every 1, 7, 14, or 28 days. Factory Default is 20minutes. When exerciser is impending, (*E*) appears in the upper right hand corner of LCD screen. See page 14 for instructions. Configured via CFG (see page 17). Set via SET menu (see page 18).

CTAP

Alarm Panel on transfer to Source 2 with Silence button.

DS

Disconnect Switch, Auto/Inhibit. Inhibits transfer in either direction when in inhibit. Allows automatic operation when in Auto. (40-400 Amps optional, 600-4000 Amps standard)

DT (Delayed Transition Only)

Time Delay from Neutral Switch position to Source 1 position. Adjustable 0-10 minutes in 1 second increments. Standard setting is 5 seconds Adjust via SET menu (see page 18)

DW (Delayed Transition Only)

Time Delay from Neutral Switch position to Source 2 position. Adjustable 0-10 minutes in 1 second increments. Standard setting is 5 seconds. Adjust via SET menu (see page 18)

E

Engine Start Contact

EL/P

Event Log: Sequentially Numbered Log of 16 events that track date, time, reason and action taken
System Data: Total Life Transfers (N2P)
Days Powered Up
Total Transfers to S2
Total S1 Failures
Time S1 available in Hrs
Time S2 available in Hrs. (N1P)

F

Fan contact, operates when generator is running.

HT

Heater and Thermostat

K

Frequency Meter, Door mount.

K/P

Frequency Indication for S1 and S2

L

LNP Center-off position LCD-Indicator
Indicating LED lights:

- L1** Indicates Switch in Source 2 position.
- L2** Indicates Switch in Source 1 position.
- L3** Indicates Source 1 available.
- L4** Indicates Source 2 available.

Accessory Definitions *(cont'd)*

M1

Single Phase Amp Meter

M2

Three Phase Amp Meter

M80

3000 Digital Power Monitor

M82

5200 Digital Power Meter

M83A

EPM 5300 Digital Power Meter with Modbus Port

M83B

EPM 5350 Digital Power Meter with Ethernet Port

M84

7430 Digital Power Meter , Wye or Delta

M85A

EPM 9450 Digital Power Meter, Ethernet

M85B

EPM 9450 Digital Power Meter with Internal 56K Mod.

M86A

EPM 9650 Digital Power Meter, Wye or Delta, RS232 or RS485

M86B

EPM 9650 Digital Power Meter, Wye or Delta, RS232 or RS485

N1

Running Time Meter, Door mount

N2

Operation Counter, Door Mount

P1

Time Delay Source 2 Start. Adjustable 0-10 seconds. Standard setting is 3 seconds. Adjust via SET menu (see page 18)

P2

Time Delay S2 Start. Adjustable 1/6 to 300 seconds.

Q2

Remote Peak Shave or Area Protection Circuit. Energize Q2 to simulate Source 1 Line failure causing the Generator to start and transfer the load to Source 2. Should Emergency fail during this operation, Transfer Switch will retransfer back to Source 1.

Q3

Remote inhibit transfer to Source 2 circuit. Energize Q3 input to allow transfer to Source 2. To enable Q3 option, engage Q3 jumper.

Q7

Inhibit transfer to Source 1 circuit. Energize Q7 input to prevent transfer to Source 1.

R1-1/R1-3

Source 1 Over Voltage sensing for single and three phase systems.

Source 1 Over Voltage "Fail"

Factory Default: 110%

This adjustment determines the maximum acceptable over voltage. Adjust via the SET menu. Range is 105% to 110% in 1% increments (see page 18).

Once exceeded, the P timer begins timing to signal the Generator to start.

Source 1 Over Voltage "Restore"

Factory Default: 105%

This adjustment determines the minimum acceptable over voltage threshold at which the Transfer Switch is allowed to automatically transfer to Source 1. Adjust via SET menu. Range is 103% to 108% in 1% increments. "Restore" must be a minimum of 2% below "Fail" setting (see page 18).

R15/R15D

Load Shed

Should Source 2 become overloaded, a signal can be given to switch to the dead or Mid position.

R16

Phase Rotation Sensing

Can be turned on or off via CFG menu (see page 17).

Factory Default is on.

This feature prevents Line Source to Line Source transfers from occurring between dissimilar phase sequences. This condition is primarily caused by an installation error. Connections from Source 1 and Source 2 need be verified, compared, and corrected to remedy the inconsistent phase rotation between the sources.

WARNING: Turning off this feature can cause severe damage to loads.

R26

Interruptable Power Rate Provisions.

Allow transfer out of Source 1 position to Source 2 or dead Source 2. Alarm and Pre-Signal circuit included.

Accessory Definitions *(cont'd)*

R50

In Phase Monitor this feature restricts **Live to Live Source Transfers** to occur unless both Sources are within 7 electrical degrees or less of each other. (live Source to live Source transfers usually occur during transfer back to Source 1 or during Testing). R50 does not change the operation of the Automatic Transfer Switch in a power failure mode. After all timer functions have elapsed, the **CHECKING FOR SOURCE SYNCHRONISM** will be displayed as well as the direction of transfer (S1-S2 for example denotes transfer from Source 1 to Source2). When synchronism is accomplished, transfer will take place.

- Notes:**
- If S2 Frequency is less than S1 Frequency, display will show a series of (-----) symbols.
 - If S2 Frequency is greater than S1 Frequency, display will show a series of (+++++) symbols.
 - Each (-) or (+) symbol represents 10 electrical degrees out of phase. A maximum of 18 symbols (180 electrical degrees) can be monitored.
 - The number of (-) or (+) symbols decrease as the two sources approach synchronism and increase as the two sources drift out of synchronism.
 - If S1 and S2 Frequencies are identical, the display will show a series of alternating symbols (+++)... which also indicate the approximate out of phase degrees

In the event that the Sources do not come within 7 electrical degrees of each other within 60 seconds, the unit will display the message: **SYNCH CHECKING** and will allow the user to **BYPASS**. If the **BYPASS** button is pressed, the unit will display the message: **WARNING MAY CAUSE DAMAGE TO THE LOAD**. Pressing **XFR** will actually bypass the R50. Since R50 is a passive device, the length of time it takes to reach Synchronism is dependent on the frequency difference between the two Sources. Source 1 is usually a Utility and the frequency is not within the control of the consumer. Source 2 needs to be adjusted to create an adequate difference in order for the transfer to happen a timely fashion.

- Note:** For optimum performance, Source 2 Generator should be adjusted a Maximum of 2 Hertz above or below the Utility frequency, minimum of 0.1 Hertz. (58 to 59.9) or (60.1 to 62) Hertz. Adjustment of Generator to 60Hertz could cause lengthy transfer delay.

R50 Feature can be turned ON or OFF via CFG Menu (see page 17). Factory Default if OFF.

S5P

Auto / Semi Manual selector

In "Auto" position, retransfer to Source 1 is automatic after the T timer has timed out. The T time delay is bypassed if Source 2 fails.

In "Manual", retransfer to Source 1 is upon depression of **BYPASS DELAY** button YEN or if Source 2 fails.

S12P

Auto / Manual Selector

In "Auto" position, the Automatic Transfer Switch functions automatically as specified with the Switch drawings.

In "Manual" the Automatic Transfer Switch will transfer to either direction upon depression of Source 1 or Source 2 transfer buttons.

Should Source 1 fail, the Generator (Source 2), will automatically start. Once transferred in Manual, the Switch maintains position selected even if selected power fails.

S13P

Transfer Commit. Configured via CFG menu.

(see page 17) When this Feature is set to OFF:

The transfer Switch is not committed to transfer unless the outage duration is longer than the timers that precede the transfer to Source 2 position. This assumes that the outage will be an isolated event. When this Feature is set to ON: The transfer Switch is committed to transfer to Source 2 position once the W timer has begun timing, even if Source 1 power returns before the transfer to Source 2. This is to ensure that the transfer takes place, because one outage may be followed by another.

S14

Test / Auto / Source 1 Selector, Door mount

SW1

Auto/Off/Start Engine control selector, Door mount (Keyed or non-keyed operation available)

SW2

Auto / Off Engine control selector, Door mount (Keyed or non-keyed operation available)

SW3

Source Priority Selector Switch, Door mount
Allows selection of Source 1 or Source 2 to be the Prime Source. Transfer Switch will transfer to selected Prime Source if that Source is available. (Keyed or non-keyed operation available)

T

Time Delay (S1) Source 1 Stable Timer. To delay transfer to Source 1 (immediate retransfer on Source 2 failure). Adjustable 0-60 minutes in 1 second increments. Standard setting is 30 minutes. Adjust via SET menu (see page 18)

T3/W3

Elevator Pre-Signal Auxiliary Contacts: Open 0-60 seconds prior to transfer to either direction, re-closes after transfer.

U

(S2) Source 2 Stop Delay Timer. Allows Engine to run unloaded after switch retransfer to Source 1. Adjustable 0-60 minutes in 1 second increments. Standard setting is 5 minutes. Adjust via SET menu (see page 18)

Accessory Definitions *(cont'd)*

UMD

Universal Motor Load Disconnect Circuit: Auxiliary Contact opens 0-60 seconds prior to transfer in either direction, re-closes after transfer. Can be configured by end user for Pre-transfer, Post-transfer, or both.

VI

Voltage Imbalance (Three Phase)

For a three phase source, this feature monitors phase voltage ratios based on a selected range within a selected time window. Should any phase fall below the selected lower window limit or exceed the selected higher window limit within the selected time frame, the controller initiates transfer to the other source.

Range: 5% to 20% of Nominal voltage,
10 to 30 seconds window, user adjustable.

Resolution: 1% Increments

Minimum Differential: 2% between "Fail"
and "Restore" settings.

Factory default: 10% "Fail", 8% "Restore", 30 Seconds.

See CFG Menu page 17 to configure ON or OFF.

See SET Menu page 18 to set Percentage and time windows

W

Time Delay (S2) Source 2 Stable Timer. To delay transfer to Source 2. Adjustable 0-5 minutes in 1 second increments. Standard setting is 1 second. Adjust via SET menu (see page 18)

YEN

Bypass Timers Key utilizing Keypad. When applicable, the system prompts the user to press a button to bypass (T) or (W) Timers should the user so desires.

ZNET

Network Communications Interface Card

How to Set the System Clock

How to Set the System Clock

Set System Clock, time and date

- If the clock is not set, the display will show SET SYSTEM CLOCK on the second line of the S1 OK screen.
- The S1 OK screen will show time (hours and minutes) on the second line if the system clock has been set. (Date on third line)

Setting the System Clock

(Start from S1 OK screen)

1. Remove battery protective white plastic strip near **P** relay. *
2. Press **MORE** then press **SET**.
3. Press **MORE** and scroll to **SET SYSTEM CLOCK** using the **MORE** key.
4. Press **SEL**.
5. **ENTER ACCESS CODE** located on the white label on the back of the controller.
6. Press **SEL**.
7. Use the up and down keys to change the hour value.
8. Press **SAVE** (this will enter this value and move cursor to minutes).
9. Use the up and down keys to change the minutes.
10. Press **SAVE** (this will enter this value and move cursor to month).

11. Use the up and down key up to change the month.
12. Press **SAVE** (This will enter this value and complete the clock setting).
13. Use the up and down keys to change the date.
14. Press **SAVE** (this will enter this value and move cursor to year).
15. Use the up and down keys to change year.
16. Press **SAVE** (this will enter this value and complete the clock setting).
17. To edit settings, press **SEL** and repeat steps 6-16.
18. If the setting is satisfactory, press **MORE** (unit then returns to the **SET** menu then press **BACK**, then **ESC**.)

- * Replacement battery part #K-4100
Battery will last 5 years and provides power to retain clock function only (Controller functions without battery).

CDT One Event Timer Exerciser

Load / No-Load

One event Exerciser with adjustable Timer. Exercise duration can be set between 5 and 60 minutes in 1 minute increments. Can be configured to run every 1,7,14, or 28 days. Factory default is 20 minutes.

How to CONFIGURE (CFG) and Set (SET) the Timer Exerciser

1. Beginning from the **S1 OK** screen, press **MORE** then **CFG**.
2. Press **MORE** to scroll to **CONFIG TIMER EXERCISER** screen.
3. The third line of the **CONFIG TIMER EXERCISER** will show either **DAILY**, **WEEKLY**, **14 DAY**, **28 DAY**, or **OFF**.
4. If the third line of the **CONFIG TIMER EXERCISER** shows **DAILY**, **WEEKLY**, **14 DAY**, or **28 DAY** as desired, then proceed to step 10.
5. If the third line of the **CONFIG TIMER EXERCISER** shows **OFF** or if another timer selection is desired, continue.
6. Press **SEL**.
7. Enter **ACCESS** code located on white label on the back of the controller.
8. Press **UP** or **DOWN** to select **DAILY**, **WEEKLY**, **14 DAY**, or **28 DAY** as desired.
9. Press **SAVE**.
10. Press **MORE** to scroll to **CONFIG TIMER EXERCISER (XFR)** or **(NO XFR)**.
11. Press Up or Down to select **XFR** (Load Transfer) or **NO XFR** (No Load Transfer).
12. Press **SAVE**.
13. Press **MORE** repeatedly to **BACK** then **S1 OK** screen.

Set (SET) the Exerciser:

14. Beginning from the **S1 OK** screen, press **MORE** then **SET**.
15. Press **MORE** repeatedly until **EXER S2 RUN TIME** screen.
16. Press **SEL**.
17. Enter **ACCESS** code located on white label on the back of the controller.
18. Press **SEL**.
19. Cursor is indicated as a line under character to be changed. Change values with up and down keys.
20. Press **SAVE** when complete.
21. Press **MORE** repeatedly until **SET USER SETUP** then press **BACK** then **ESC** to the **S1 OK** screen.

How to Initiate CDT Exerciser and to start an exercise cycle every 1, 7, 14, or 28 days

From S1 screen

- 1) Press **TEST**
- 2) Press **MORE**
- 3) Press **START TEST TIMER** (to initiate Test).

- If the CDT Exerciser is Factory configured for a Load Exerciser, the Controller will immediately start a load exercise. The controller will start the generator, transfer the load to Source 2 and remain in Source 2 for the duration set for **EXER S2 RUN TIME** in the **SET** menu. The controller will retransfer the load back to Source 1 after the S1 stable timer has timed out and run the generator unloaded for the duration of the S2 stop delay timer (Engine Cool Down Timer).
- If the CDT Exerciser is Factory configured for a No-Load Exerciser, the Controller will immediately start a No-load exercise. The controller will start the generator and run it unloaded for the duration of the S2 stop delay timer (Engine Cool Down Timer).

Exercise will be repeated at the same time as initiated on every 1, 7, 14, or 28 days according to the selection made in the Configure **CFG** menu.

How to Bypass (Cancel) an exercise during an exercise cycle

- 1) Press **BPASS**
- 2) Allow the controller to complete the Engine cool down cycle

If the CDT Exerciser is Factory configured for a No-Load Exerciser Or allow the controller to complete retransfer to Source 1 If the CDT Exerciser is Factory configured for a Load Exerciser

How to Bypass the next exercise event and Keep the rest of scheduled events unchanged

- 1) Press **Test**
- 2) Press **MORE**
- 3) Press **BYPASS EXER**

To re-institute the next exercise event back, press **CANCL BPASS**

How to initiate a new exercise start time

- 1) Press **TEST**
- 2) Press **MORE**
- 3) Press **EXER CANCL**
- 4) Press **START TIMER TEST**

How to check the next exercise event

- 1) From **S1 OK** screen, press **MORE** three times.
- 2) The unit will display the **PLANT EXERCISER NEXT** event in **DAYS**, **HOURS**, and **MINUTES**
- 3) Press **ESC** to **S1 OK** Screen.

Notes:

- *E* appears in the upper right hand corner of LCD screen when exercise is impending.
- For Load Exerciser, actual exercise period (ATS in S2 position)= CDT (Exerciser) timing period +T (S1 stable Timer) timing period.

CDP Clock Exerciser

Load / No-Load Clock Exerciser

Allows the Generator to start and run unloaded or to simulate a power failure, start Generator and run under load. Can be configured by the end user for 1, 7, 14, 28, or 365 day cycles.

- A total of 7 independent No Load exercise periods (up to 10 hours each) can be programmed for each of the daily, weekly, 14-day, and 28-day exercisers.
- A total of 12 independent No Load exercise periods (up to 10 hours) can be programmed for the 365-day Exerciser.

How to Configure (CFG) the Exerciser

1. Beginning from the **S1 OK** screen, press **MORE** then **CFG**.
2. Press **MORE** to scroll to **CONFIG CLOCK EXERCISER** screen.
3. The third line of the **CONFIG CLOCK EXERCISER** will show either **DAILY**, **WEEKLY**, **14 DAY**, **28 DAY**, **365 DAY** or **OFF**.
4. If the third line of the **CONFIG CLOCK EXERCISER** shows **DAILY**, **WEEKLY**, **14 DAY**, **28 DAY**, or **365 DAY** as desired, press **MORE** repeatedly to **BACK**. Press **ESC** then proceed to the **SET** menu to set the **EXERCISER**.
5. If the third line of the **CONFIG CLOCK EXERCISER** shows **OFF**, continue.
6. Press **SEL**.
7. Enter **ACCESS** code located on white label on the back of the controller.
8. Press **UP** or **DOWN** to select **DAILY**, **WEEKLY**, **14 DAY**, **28 DAY**, or **365 DAY** as desired.
9. Press **SAVE**.
10. Press **MORE** repeatedly to **BACK** then **ESC** to **S1 OK** screen.

How to set (SET) the DAILY Exerciser

1. Beginning from the **S1 OK** screen, press **MORE** then **SET**.
2. Press **MORE** repeatedly until **SET EXERCISER** screen.
3. Press **SEL**.
4. Enter **ACCESS** code located on white label on the back of the controller.
5. Press **SEL**

6. Cursor is indicated as a line under character to be changed. Change values with up and down keys. Press **SAVE** after each entry to save value and to move to the next value to be changed.
7. Press **BACK** when complete.
8. Press **MORE** repeatedly until **SET USER SETUP**. Press **BACK** then **ESC** to the **S1 OK** screen.

How to Bypass (Cancel) an exercise during an exercise cycle

- 1) Press **BPASS**
- 2) Allow the controller to complete the Engine cool down cycle.

If the CD Exerciser is configured or Set for a No-Load Exercise. Or allow the controller to complete retransfer to Source 1. If the CD Exerciser is configured for a Load Exerciser

How to Bypass the next exercise event and Keep the rest of scheduled events unchanged

- 1) Press **TEST**
- 2) Press **MORE**
- 3) Press **BYPASS EXER**

To re-institute the next exercise event back, press **CANCL BPASS**

How to check the next exercise event

- 1) From **S1 OK** screen, press **MORE** three times.
- 2) The unit will display the **PLANT EXERCISER NEXT** event in **DAYS**, **HOURS**, and **MINUTES**
- 3) Press **ESC** to **S1 OK** Screen.

Notes:

- In the **S1 OK** screen, an (*E*) appears in the upper right hand corner of LCD screen when exercise is impending.
- For Load Exerciser, actual exercise period (ATS in S2 position)= **CDT** (Exerciser) timing period +T (S1 Stable Timer) timing period.
- A value greater than zero must be entered in the Exerciser duration field to be accepted as a valid exercise period.
- The Exercise cycle will be repeated on a regular basis as programmed and initiated in the **SET** menu depending on what Exerciser was configured (selected) in the **CFG** menu.

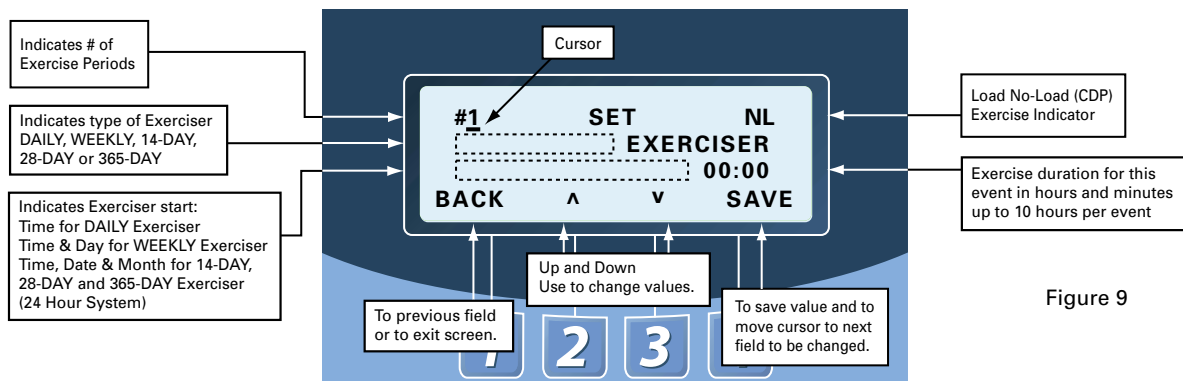
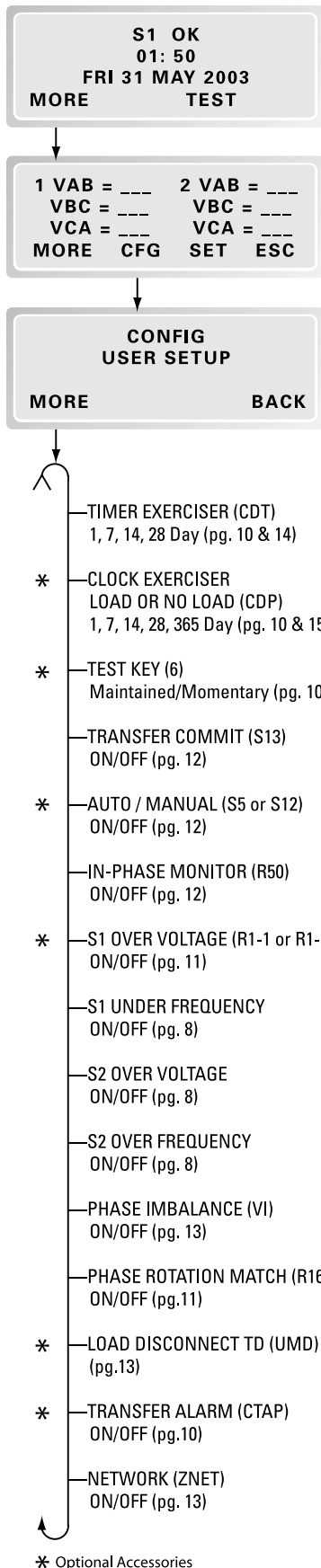

Figure 9

Entelli-Switch 250 User Setup - CFG Menu



Turn options ON or OFF via keypad through the CFG menu

Enter six digit access code
(The factory assigned six-digit access code is located on the back of the controller)

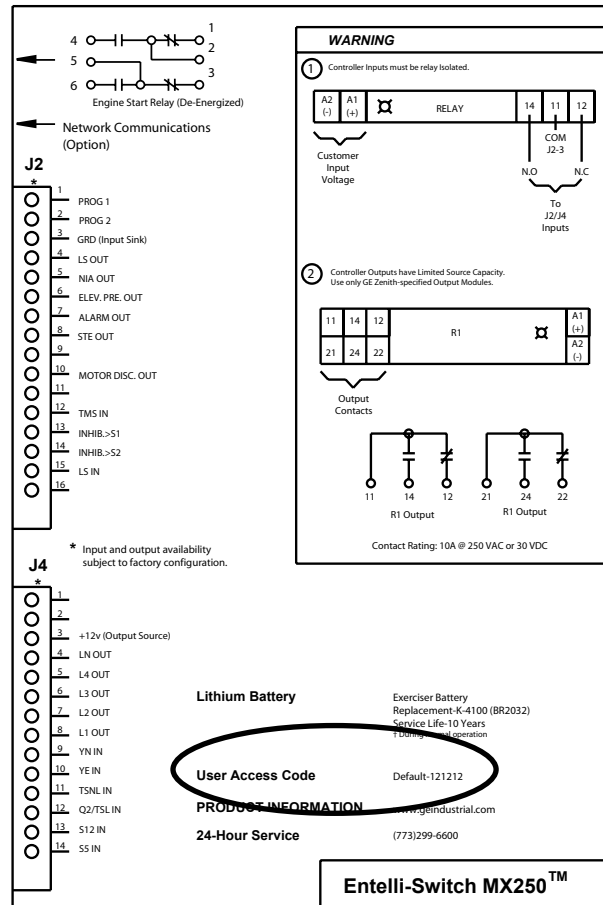
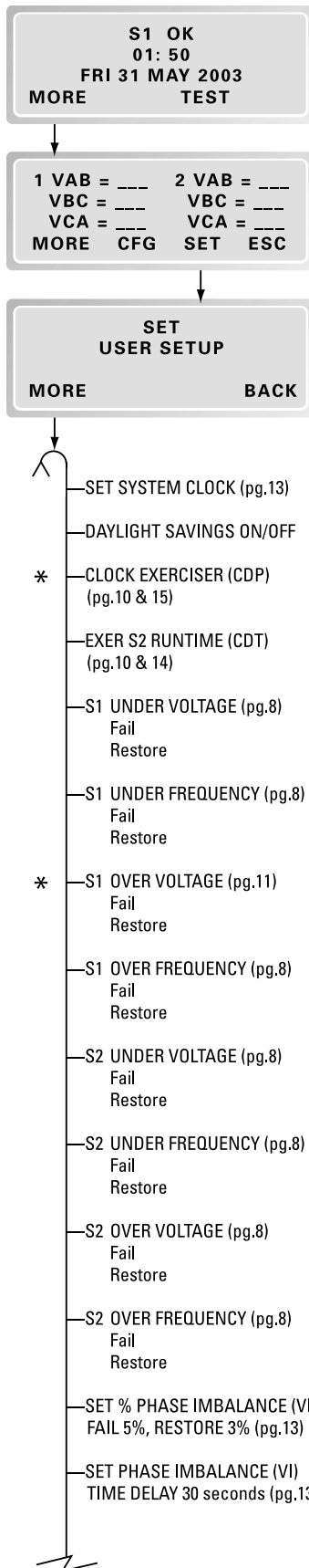

Figure 10

Entelli-Switch 250 User Setup - SET Menu



Change adjustable values through the SET menu.

Enter six digit access code
(The factory assigned six-digit access code is located on the back of the controller)

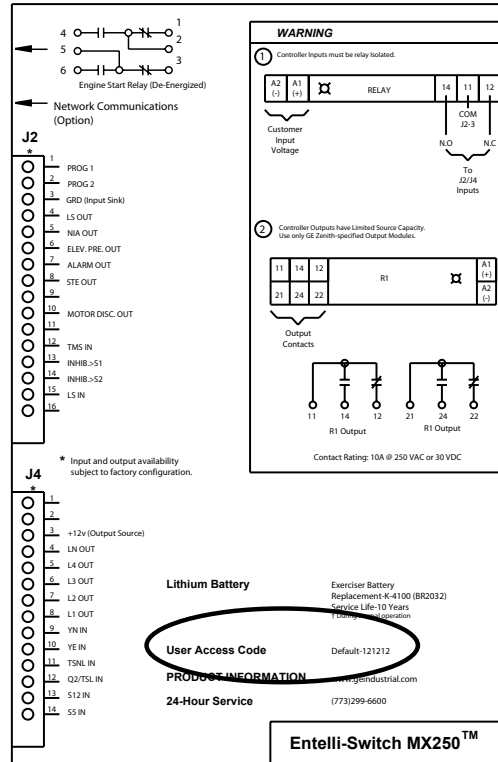
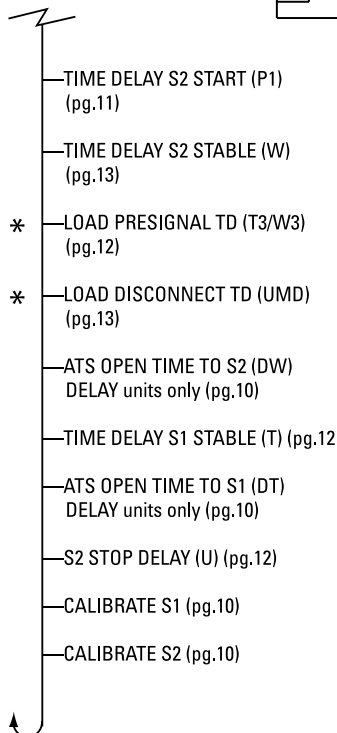

Figure 10



* Optional Accessories

Entelli-Switch 250 User Setup - System Info

S1 OK
01: 50
FRI 31 MAY 2003
MORE TEST

- PHASE TO PHASE VOLTAGE, S1 & S2
- FREQUENCY INDICATION FOR S1 & S2 (K/P) (pg.10)
- PLANT EXERCISER:
Next Impending Exerciser (shows only if set)
- SYSTEM INFO:
 - Serial #: Unit Serial #
 - Rev #: Software Revision #
 - Event Log: Sequentially Numbered Log of 16 events that track date, time, reason and action taken
 - Data:
 - Total Life Transfers (N2P)
 - Days Powered Up
 - Total Transfers to S2
 - Total S1 Failures
 - Time S1 available in Hrs
 - Time S2 available in Hrs. (N1P)
- CHANGE USER ACCESS CODE

View System Data

Enter six digit access code
 (The factory assigned six-digit access code is located on the back of the controller)

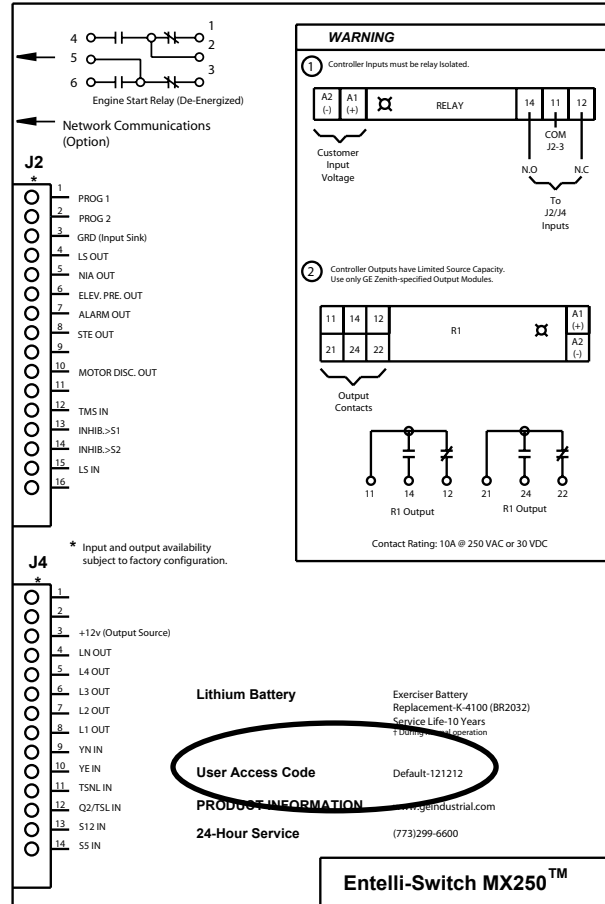

Figure 10

⚠ NOTICE ⚠

A periodic test of the transfer switch under load conditions is recommended to insure proper operation. (See National Electric Code articles 700 and 701)

ATS Testing

Start generator and verify proper voltage, frequency and phase sequence (match to Source 1). Shut down gen set and place in Auto. Complete the visual inspection of the transfer switch, and close the cabinet door.

Initiate the test by pressing the TEST button on the LCD keypad. The controller will then prompt for your access code. After entering the code, three test options will appear—XFR LOAD, FAST TEST and NO XFR (See Figure 11).

- **XFR LOAD** test starts the generator and using the current timer settings, transfers the load to Source 2.
- **FAST TEST** test presets timer values to a maximum 30 seconds during the test. After completion of the test, all timers are reset to their original values. (T3, W3, DT and DW remain)
- **NO XFR** test starts the generator but does not transfer the load to the Source 2.

Press and hold the desired test option button until the switch transfers to Source 2 (load test) or until the generator has been run for the desired amount of time (no load test). Releasing the test button before W timer timeout will abort the test (Exception: when the transfer commit option, is configured "ON").

To test lamps, press TEST then scroll through MORE, then press LAMP TEST. To cancel LAMP TEST press MORE.

Standard Transition

When the test is initiated, the controller initiates the Time Delay Source 2 Start Timer (Engine Start Timer "P") cycle. A manual CANCEL button is provided to cancel the test if desired. Upon completion of the (P) time delay, an Engine start Signal is sent to Source 2. When Source 2 voltage and frequency reach the preset "Restore" Values, the time delay to Source 2 Timer (W) begins its timing cycle to ensure voltage and frequency stabilization before transfer. A manual pushbutton BYPASS is provided to bypass the "W" time delay if desired. After the (W) time delay, the MX controller initiates a transfer signal through the SCR-E to operate the main transfer operator. The load is now transferred to Source 2 line. The transfer switch is mechanically locked. SN limit switch awaits the next operation to Source 1.

Restoration of Source 1 Power:

Deactivating the test switch initiates re-transfer to Source 1 sequence. The delay to Source 1 Timer (T) begins its timing cycle to ensure voltage and frequency stabilization before retransfer. A manual pushbutton BYPASS is provided to bypass the "T" time delay if desired. After the (T) time delay, the MX controller initiates a transfer signal through the SCR-N to operate the main transfer operator. The load is now transferred to Source 1 line. The transfer switch is mechanically locked. SE limit switch awaits the next operation to Source 2.

Immediately after re-transfer, the S2 Stop Delay Timer (Delay

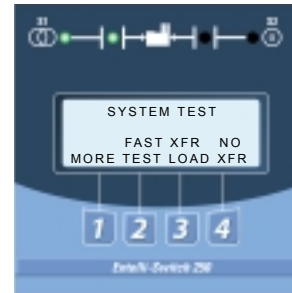

Figure 11

to Engine Stop "U") begins its cycle to allow Source 2 Engine to run unloaded. A manual pushbutton BYPASS is provided to bypass the "U" time delay if desired. Upon completion of the (U) timing cycle, the controller sends an Engine stop signal.

Delayed Transition

Source 1 Power Failure:

When the test is initiated, the controller initiates the Time Delay Source 2 Start (Engine Start Timer "P") cycle. A manual CANCEL button is provided to cancel the test if desired. Upon completion of the (P) time delay, an Engine start Signal is sent to Source 2. When Source 2 voltage and frequency reach the preset "Restore" values, the time delay to open Source 1 timer (W) begins its timing cycle to ensure voltage and frequency stabilization before re-transfer. A manual pushbutton BYPASS is provided to bypass the "W" time delay if desired. After the (W) time delay, the MX controller initiates a transfer signal through the SCR-NO to operate the main transfer operator. The load is now transferred to the Open position. The time delay to Source 2 timer (DW) begins its timing cycle. After the (DW) time delay, the MX controller initiates a transfer signal through the SCR-E to operate the main transfer operator. The load is now transferred to Source 2 line. The transfer switch is mechanically locked. SN limit switch awaits the next operation to Source 1.

Restoration of Source 1 Power:

Deactivating the test switch initiates re-transfer to Source 1 sequence. The delay to open Source 2 Timer (T) begins its timing cycle to ensure voltage and frequency stabilization before retransfer. A manual pushbutton BYPASS is provided to bypass the "T" time delay if desired. After the (T) time delay, the MX controller initiates a transfer signal through the SCR-EO to operate the main transfer operator. The load is now transferred to the Open position. The time delay to Source 1 timer (DT) begins its timing cycle. After the (DT) time delay, the MX controller initiates a transfer signal through the SCR-N to operate the main transfer operator. The load is now transferred to Source 1 line. The transfer switch is mechanically locked. SE limit switch awaits the next operation to Source 2.

Immediately after re-transfer, the S2 Stop Delay Timer (Delay to Engine Stop "U") begins its cycle to allow Source 2 Engine to run unloaded. A manual pushbutton BYPASS is provided to bypass the "U" time delay if desired. Upon completion of the (U) timing cycle, the controller sends an Engine stop signal.

Sequence of Operation

Standard Transition

Source 1 Power Failure:

When Source 1 voltage or frequency has fallen below the preset "Fail" values, the controller initiates the Time Delay Source 2 Start Timer (Engine Start Timer "P") cycle. Upon completion of the (P) time delay, an Engine start Signal is sent to Source 2. When Source 2 voltage and frequency reach the preset "Restore" Values, the time delay to Source 2 Timer (W) begins its timing cycle to ensure voltage and frequency stabilization before transfer. A manual pushbutton BYPASS is provided to bypass the "W" time delay if desired. After the (W) time delay, the MX controller initiates a transfer signal through the SCR-E to operate the main transfer operator. The load is now transferred to Source 2 line. The transfer switch is mechanically locked. SN limit switch awaits the next operation to Source 1.

Restoration of Source 1 Power:

When Source 1 power reach the preset "Restore" values, the controller initiates re-transfer to Source 1 sequence. The delay to Source 1 Timer (T) begins its timing cycle to ensure voltage and frequency stabilization before retransfer. A manual pushbutton BYPASS is provided to bypass the "T" time delay if desired. After the (T) time delay, the MX controller initiates a transfer signal through the SCR-N to operate the main transfer operator. The load is now transferred to Source 1 line. The transfer switch is mechanically locked. SE limit switch awaits the next operation to Source 2.

Immediately after re-transfer, the S2 Stop Delay Timer (Delay to Engine Stop "U") begins its cycle to allow Source 2 Engine to run unloaded. A manual pushbutton BYPASS is provided to bypass the "U" time delay if desired. Upon completion of the (U) timing cycle, the controller sends an Engine stop signal.

Delayed Transition

Source 1 Power Failure:

When Source 1 voltage or frequency has fallen below the preset "Fail" values, the controller initiates the Time Delay Source 2 Start (Engine Start Timer "P") cycle. Upon completion of the (P) time delay, an Engine start Signal is sent to Source 2. When Source 2 voltage and frequency reach the preset "Restore" values, the time delay to open Source 1 timer (W) begins its timing cycle to ensure voltage and frequency stabilization before re-transfer. A manual pushbutton BYPASS is provided to bypass the "W" time delay if desired. After the (W) time delay, the MX controller initiates a transfer signal through the SCR-NO to operate the main transfer operator. The load is now transferred to the Open position. The time delay to Source 2 timer (DW) begins its timing cycle. After the (DW) time delay, the MX controller initiates a transfer signal through the SCR-E to operate the main transfer operator. The load is now transferred to Source 2 line. The transfer switch is mechanically locked. SN limit switch awaits the next operation to Source 1.

Restoration of Source 1 Power:

When Source 1 power reach the preset "Restore" values, the controller initiates re-transfer to Source 1 sequence. The delay to open Source 2 Timer (T) begins its timing cycle to ensure voltage and frequency stabilization before retransfer. A manual pushbutton BYPASS is provided to bypass the "T" time delay if desired. After the (T) time delay, the MX controller initiates a transfer signal through the SCR-EO to operate the main transfer operator. The load is now transferred to the Open position. The time delay to Source 1 timer (DT) begins its timing cycle. After the (DT) time delay, the MX controller initiates a transfer signal through the SCR-N to operate the main transfer operator. The load is now transferred to Source 1 line. The transfer switch is mechanically locked. SE limit switch awaits the next operation to Source 2.

Immediately after re-transfer, the S2 Stop Delay Timer (Delay to Engine Stop "U") begins its cycle to allow Source 2 Engine to run unloaded. A manual pushbutton BYPASS is provided to bypass the "U" time delay if desired. Upon completion of the (U) timing cycle, the controller sends an Engine stop signal.

Table 4

Timer Designations as they appear in the SET menu						
ATS Type	P	W	DW	T	DT	U
Standard Transition	Time Delay S2 Start	Time Delay S2 Stable	→	Time Delay S1 Stable	→	S2 Stop Delay
Delayed Transition	Time Delay S2 Start	Time Delay S2 Stable	ATS Open Time to S2	Time Delay S1 Stable	ATS Open Time to S1	S2 Stop Delay
Source 1 Fails	Transfer to Source 2		↓	Source 1 Returns	Transfer to Source 1	
	→				→	
						Engine Cooldown

Controls Power Supply (CPS)

Standard and Delay Transition

Each Entelli-Switch 250 microprocessor based ATS controller requires a Controls Power Supply (CPS) to apply line voltage to the ATS operator via SCRs. Also required is power for the Entelli-Switch 250 printed circuit board and an application of sensing voltage proportional to line

voltage. This is accomplished by the Controls Power Supply (CPS). This method of switching operator voltage and applying power and sensing voltage to the printed circuit board isolates the MX250 from the line voltage, further protecting the controller from harmful line transients.

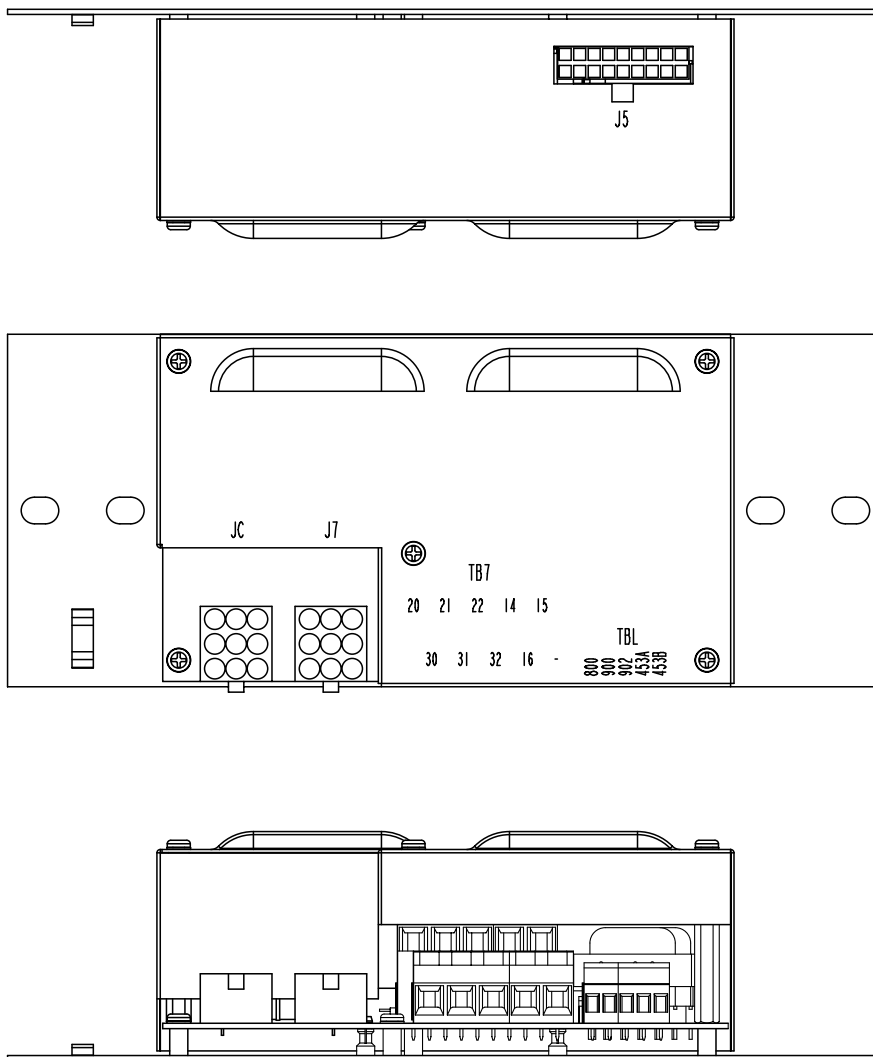

Primary Voltage at 50/60 Hz	CPS Assembly Part No.	CPS Board No.
120V	50P-1224	50P-1200
208-220V	50P-1225	50P-1201
230-240V	50P-1226	50P-1202
277V	50P-1227	50P-1203
380-400V	50P-1228	50P-1204
416-440V	50P-1229	50P-1205
460-480V	50P-1230	50P-1206
575-600V	50P-1231	50P-1207

Controls Power Supply (CPS) *(cont'd)*

Standard Transition CPS Schematic

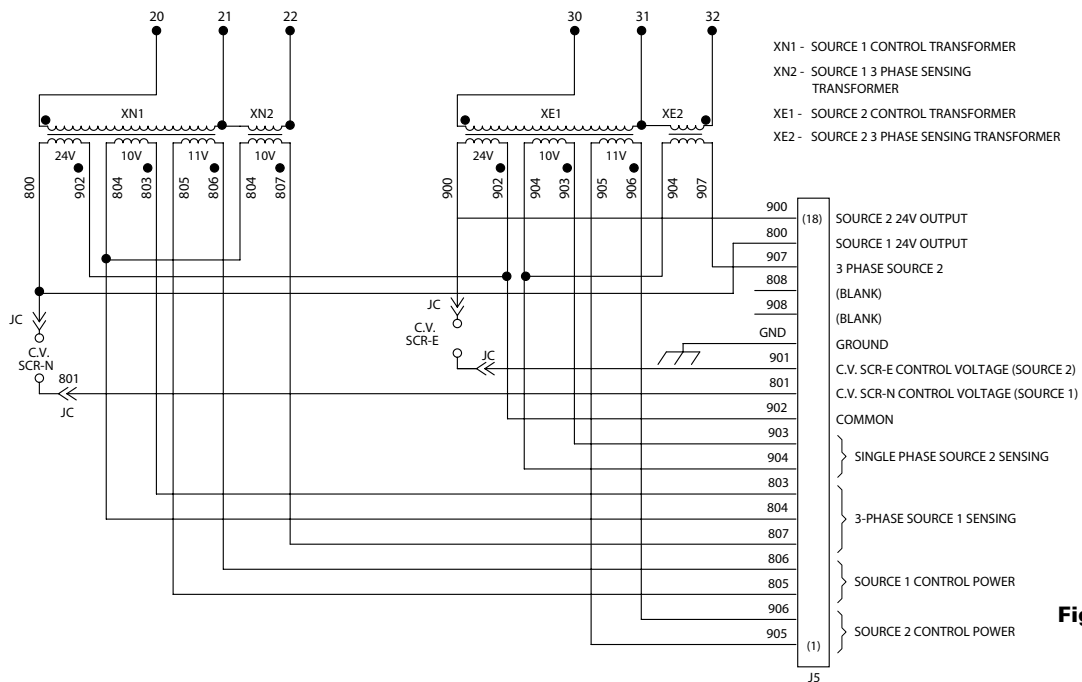

Figure 15

Delayed Transition CPS Schematic

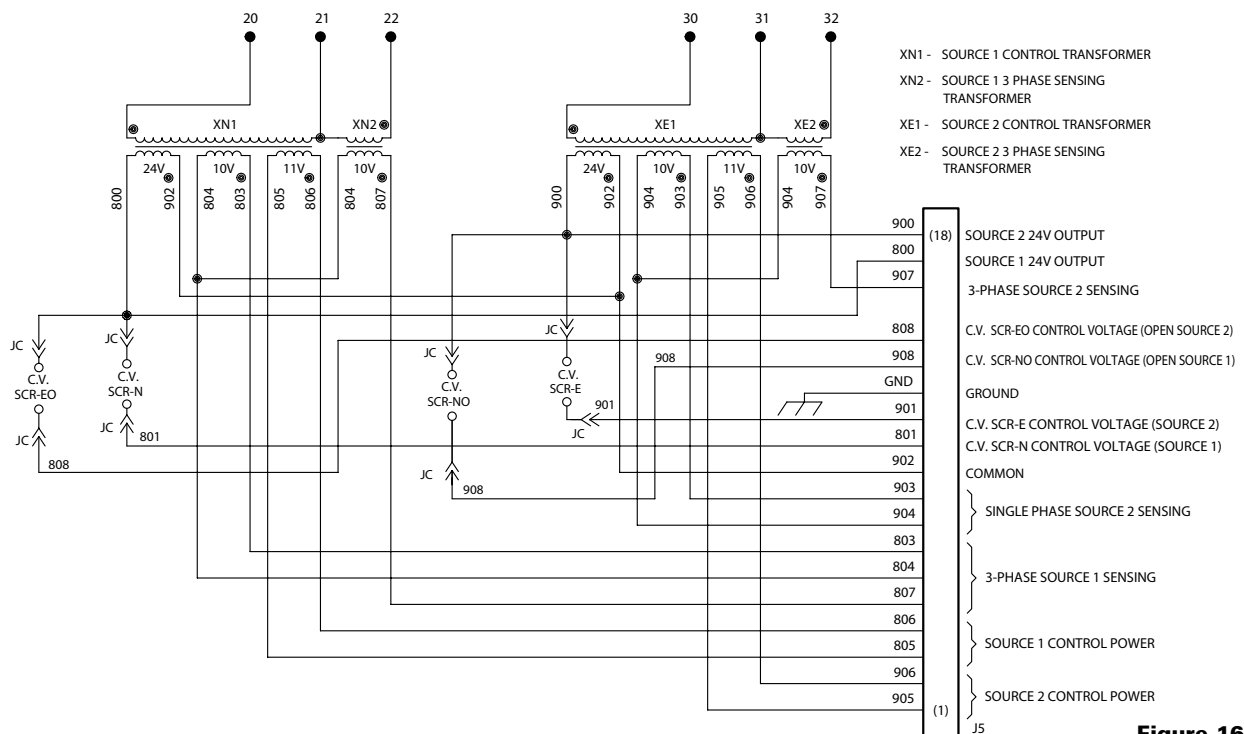

Figure 16

Troubleshooting and Diagnostics

⚠ DANGER ⚠

HAZARDOUS VOLTAGES CAN CAUSE SEVERE INJURY OR DEATH.

These charts may indicate problems that require authorized GE Zenith service personnel. Hazardous voltages may exist on termination plugs other than those that go into the Entelli-Switch 250.

General Troubleshooting

The following troubleshooting guide is used to recognize, and determine basic faults. When using this guide, it will ask several questions about the condition of the switch. This guide will then list an order of the possible faults. You will then look at the first suspected fault to determine if it is the problem. If it is not a fault, you go to the second suspected fault. If you go through all of the

suspected faults, or the chart instructs you to, call a GE Zenith Representative for further assistance.

NOTE: When you use the troubleshooting charts, the Annunciation column refers to the LED's on the control panel.

Symptom	Annunciation	Possible Cause(s)	Corrective Action
Engine does not START	SOURCE 2 AVAILABLE LED off	Engine start wires not terminated properly	Check engine start connections
		Generator is in OFF position	Investigate why Engine Control Switch was turned off
Engine does not stop	LCD Display - "TD Engine Cool Down"	U timing cycle not complete	Check U timer setting
	SOURCE 1 POSITION, and SOURCE 1 and SOURCE 2 AVAILABLE LEDs on, but U timer has timed out	Engine start wires not terminated correctly	Check Engine Start Connections
Generator in MANUAL		Place generator in AUTO	
ATS will not transfer to SOURCE 2	SOURCE 2 AVAILABLE LED off	SOURCE 2 voltage or frequency not within acceptable parameters	Check: Engine Start Connections, Generator Breaker, Generator Output, and Engine Control Switch
	None	Power supply connector unplugged	Plug in connector
	LCD Display - "S1 ____ TD XFR S1>S2 Time Remaining ____"	W timing cycle not complete	Check W Timer setting
ATS will not transfer to SOURCE 1	LCD Display - "ATS Open Time Remaining ____"	DW timing cycle not complete	Check DW Timer setting
	SOURCE 1 AVAILABLE LED off	SOURCE 1 voltage or frequency not within acceptable parameters	Check utility and utility breakers
	None	Power supply connector unplugged	Plug in connector
	LCD Display - "Diagnostic Code 001"	Limit switch or RT box connector unplugged	Call Technical Services
	LCD Display - "S1 OK Time Remaining ____ Bypass"	T timing cycle not complete	Check T Timer setting
	LCD Display - "ATS Open Time Remaining ____"	TD timing cycle not complete	Check DT Timer setting

Table 5

Maintenance and Testing

⚠ CAUTION ⚠

Due to hazardous voltage and current, GE Zenith recommends that a GE Zenith Certified technician or a qualified electrician must perform the installation and maintenance of the switch.

⚠ WARNING ⚠

Both power sources must be disconnected before manual operation of the switch.

A preventive maintenance program will insure high reliability and long life for the transfer switch. The preventive maintenance program for the transfer switch should include the following items:

Inspection and Cleaning

The switch should be inspected for any accumulation of dust, dirt, or moisture, and should be cleaned by vacuuming or wiping with a dry cloth or soft brush. do not use a blower since debris may become lodged in the electrical and mechanical components and cause damage.

Remove the transfer switch barriers and check the condition of the contacts. Any surface deposits must be removed with a clean cloth (do not use emery cloth or a file). If the contacts are pitted or worn excessively, they should be replaced. A general inspection of mechanical integrity should be made to include loose, broken or badly worn parts.

Servicing

All worn or inoperative parts must be replaced using GE Zenith recommended replacement parts. Please refer to the Replacement Parts manual for specific part information and ordering procedures. Please contact the GE Zenith Technical Services Department for the Replacement Parts manual.

The operating mechanism of the transfer switch is lubricated with Lubriplate 105. The lubricant applied at the factory provides adequate lubrication for the lifetime of the switch. Should debris contaminate the mechanism, clean and apply additional Lubriplate.

GE Zenith can provide complete preventative maintenance services. Please contact the GE Zenith Technical Services Department for additional information.

CDT battery replacement - lithium batteries may last up to 10 years, however it is recommended that battery replacement be included in a 3-5 year service cycle. The battery maintains the exerciser memory only and does not otherwise affect the operation.

Testing

A manual operator handle is provided with the transfer switch for maintenance purposes only. Manual operation of the switch must be checked before it is operated electrically. **Both power sources must be disconnected before manual operation of the switch.** Insert the handle and operate the transfer switch between the Source 1 and Source 2 positions. The transfer switch should operate smoothly without binding. Return the switch to Source 1 position, remove the handle, and return it to the holder provided.

After completing the inspection, cleaning and servicing of the transfer switch, reinstall the switch cover, and close and lock the cabinet door. Reclose the circuit breakers feeding the utility and generator sources to the switch.

Initiate the electrical transfer test by activating the TS test switch. P timer will time out and the micro-controller will send an engine start signal. When the W time has elapsed, the switch will complete its transfer by closing into Source 2.

Deactivating the test switch will start retransfer to Source 1. The switch will complete its retransfer to Source 1 after the time delay of the T timer. The U engine overrun timer allows the engine generator to run unloaded for a preset cool down period.

NOTE: A periodic test of the transfer switch under load conditions is recommended to insure proper operation. (See National Electric Code articles 700 and 701).

⚠ WARNING ⚠

When performing a hi-pot or dielectric test on the power section, DISCONNECT the control panel plugs from the microprocessor to avoid potential damage.

Replacement Parts

Standard Transition - 40 to 200 Amps

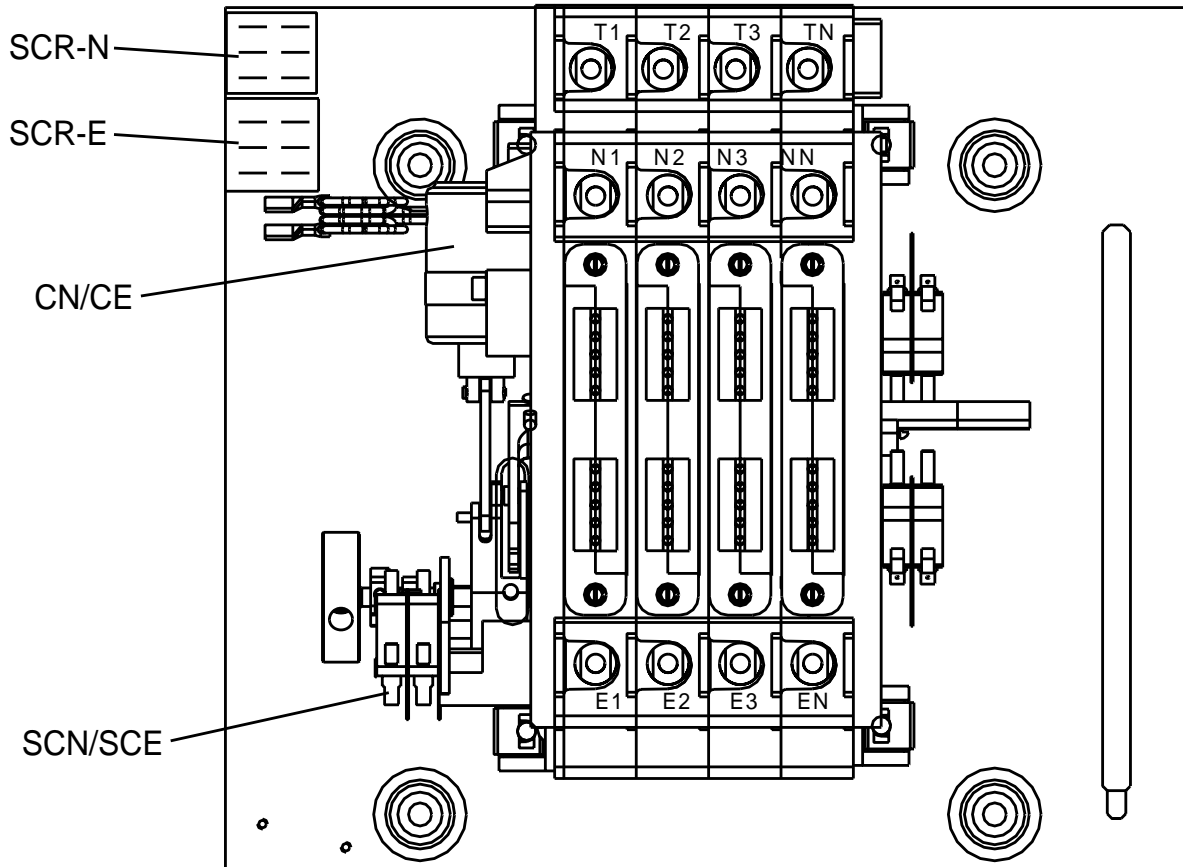

Figure 17

TAG	DESCRIPTION	VOLTAGE	40 TO 200 AMPS
CN/CE	Solenoid	120	K-2207
		208	K-2208
		220	K-2208
		240	K-2228
		277	K-2211
		380/416	K-2212
		440/480	K-2209
		575/600	K-2213
	Solenoid Plunger and Link	ALL	57P-1030
SCN/SCE	Coil Cutout Switch	120-480V	L-3078
SCN/SCE	Coil Cutout Switch	600V	L-4027
SCR-N/ SCR-E	SCR	ALL V	PS-8895
A3/A4	Auxiliary Contacts		L-3078

Replacement Parts *(cont'd)*

Standard Transition - 225 to 400 Amps

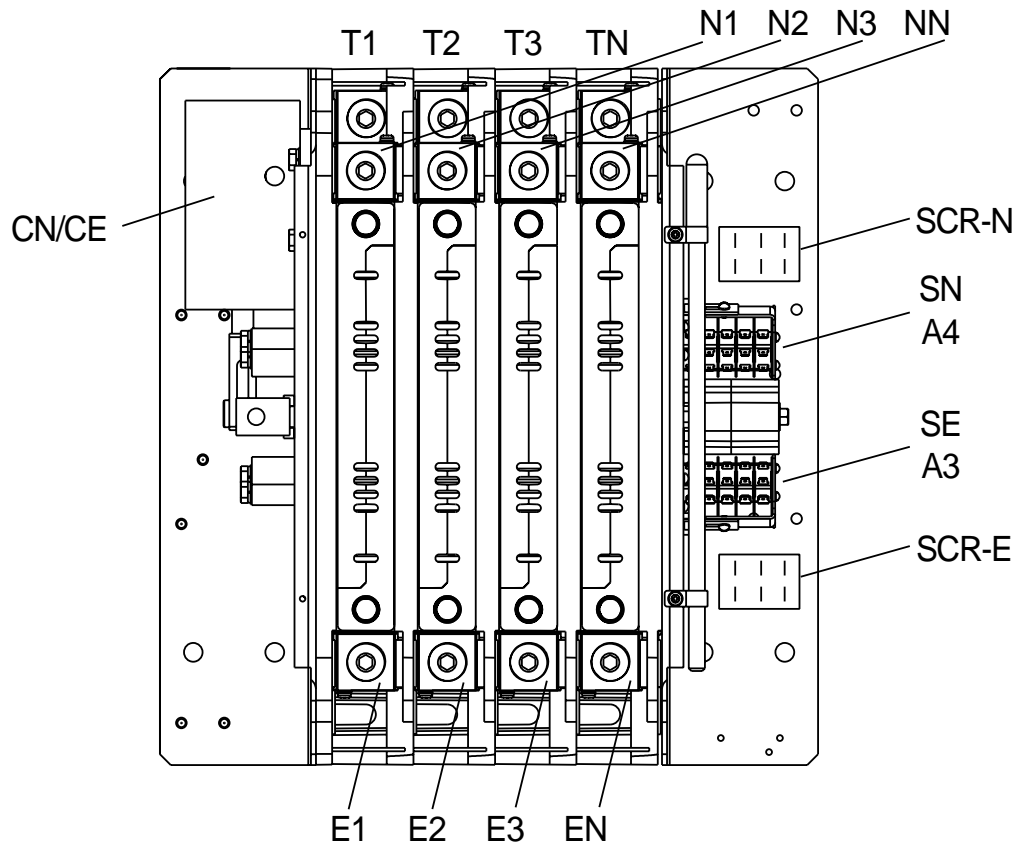

Figure 18

Tag	Description	Recommended as Spares	Stock Numbers by Amperage	
			400	600
N 1,2,3 N E 1,2,3 N T 1,2,3 N	Cable Connection Lug		S-2701	S-1393F
	Wire Size		#4-600 MCM	#2-600 MCM
			Coil Volts	
CN/CE	Solenoid	*	120	K-2245B
			208/220	K-2246B
			380/416	K-2247B
			440/480	K-2248B
			575/600	K-2249B
SN/SE	Coil Cutout Switches		L-3078	
A3/A4	Auxiliary Contacts			
SCR-N/SCR-E	SCR	*	PS-8895	

Replacement Parts *(cont'd)*

Standard Transition - 600 to 1200 Amps

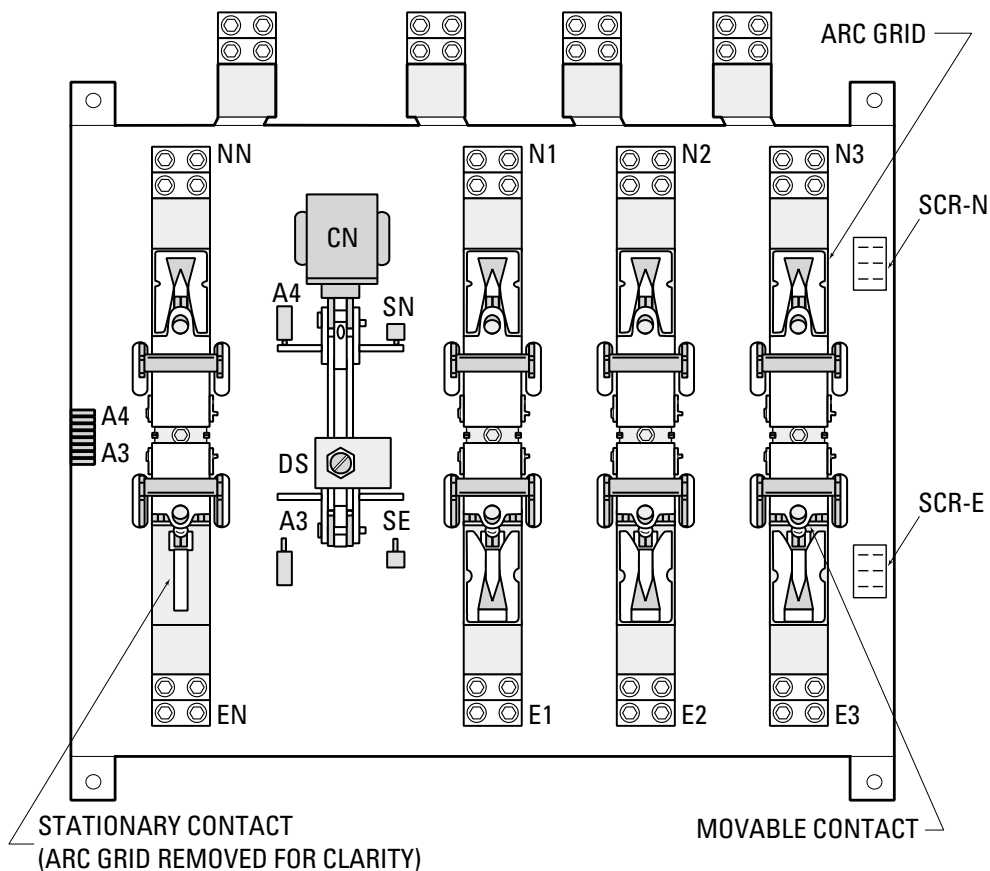

Figure 19

Tag	Description	Stock Numbers by Amperage	
		600	800-1200
N 1,2,3, N E 1,2,3, N T 1,2,3, N	Cable Connection Lug	S1393F (2)	S1392F (4)
	Wire Size	#2-600 MCM	
	Stationary Contact Assembly Kit	Consult Factory	
	Arc Grid Assembly Kit	23P-1366	
	Movable Contact Assembly Kit	Consult Factory	
CN/CE	Main Operating Coils	Coil Volts	Poles
		208/240	2, 3, 4
		380/416	3
		480	3, 4
		575/600	3, 4
SN	CCN Cutout Switch	23P-1333	23P-1333
SE	CCE Cutout Switch	23P-1327	23P-1452
A3	Emergency Position Auxiliary Contact	(Qty 1) 23P-1327 (Qty 2) 23P-1328 (Qty 3) 23P-1334 (Qty 4) 23P-1336	
A4	Normal Position Auxiliary Contact	(Qty 1) 23P-1333 (Qty 2) 23P-1334 (Qty 3) 23P-1328 (Qty 4) 23P-1330	
DS	Disconnect Switch (older versions)	Operator L-4009; Contact Block L-1020	Operator L-4009; Contact Block L-1020
SCR-N/SCR-E	SCR	PS-8896	

Replacement Parts *(cont'd)*

Standard Transition - 1600 to 3000 Amps

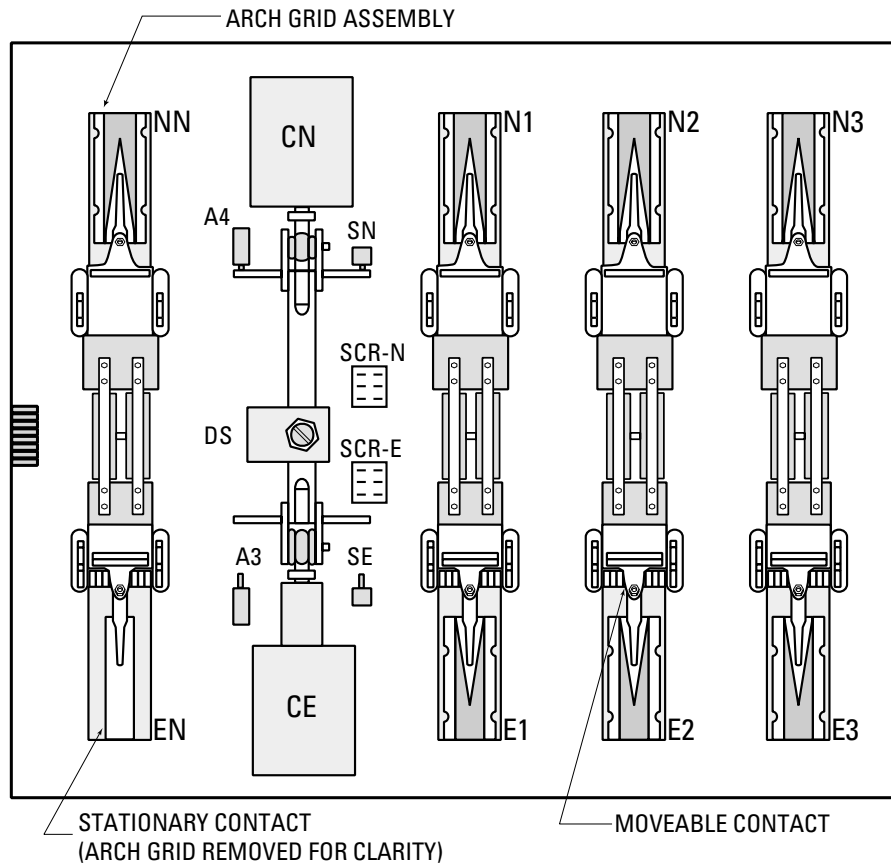

Figure 20

TAG	DESCRIPTION	STOCK NUMBERS BY AMPERAGE				
		1600	2000	3000		
N 1,2,3, N E 1,2,3, N T 1,2,3, N	Cable Connection Lug	S1126F (2) Optional	S1126F (2) Optional	S1126F (2) Optional		
	Wire Size	(8) #2-600 MCM	(8) #2-600 MCM	(8) #2-600 MCM		
	Stationary Contact Assembly Kit	23P-1594	23P-1594	23P-1594		
	Arc Grid Assembly Kit	23P-1171	23P-1171	23P-1171		
	Movable Contact Assembly Kit	23P-1400	23P-1400	23P-1400		
CN/CE	Main Operating Coils	Coil Volts	Poles			
		120	2	SPO	SPO	SPO
	240	2,3	K-2123F	K-2123F	K-2123F	
		4	K-2127F	K-2127F	K-2127F	
	208	3	K-2125F	K-2125F	K-2125F	
		4	K-2128F	K-2128F	K-2128F	
	575/600	3	K-2153F	K-2153F	K-2153F	
		4	K-2154F	K-2154F	K-2154F	
	480	3	K-2120F	K-2120F	K-2120F	
		4	K-2130F	K-2130F	K-2130F	
416	3	K-2126F	K-2126F	K-2126F		
SN	CCN Cut-out Switch	23P-1352				
SE	CCE Cut-out Switch	23P-1356				
A3	Emergency Position Aux Contact	(Qty 1) 23p-1356 (Qty 2) 23p-1357 (Qty 3) 23p-1353 (Qty 4) 23p-1355				
A4	Normal Position Aux Contact	(Qty 1) 23p-1352 (Qty 2) 23p-1353 (Qty 3) 23p-1357 (Qty 4) 23p-1359				
DS	Disconnect Switch	Operator L-4009; ; Contact Block L-1020				
SCR-N/SCR-E	SCR	PS-8896				

Replacement Parts *(cont'd)*

Standard Transition - 4000 Amps

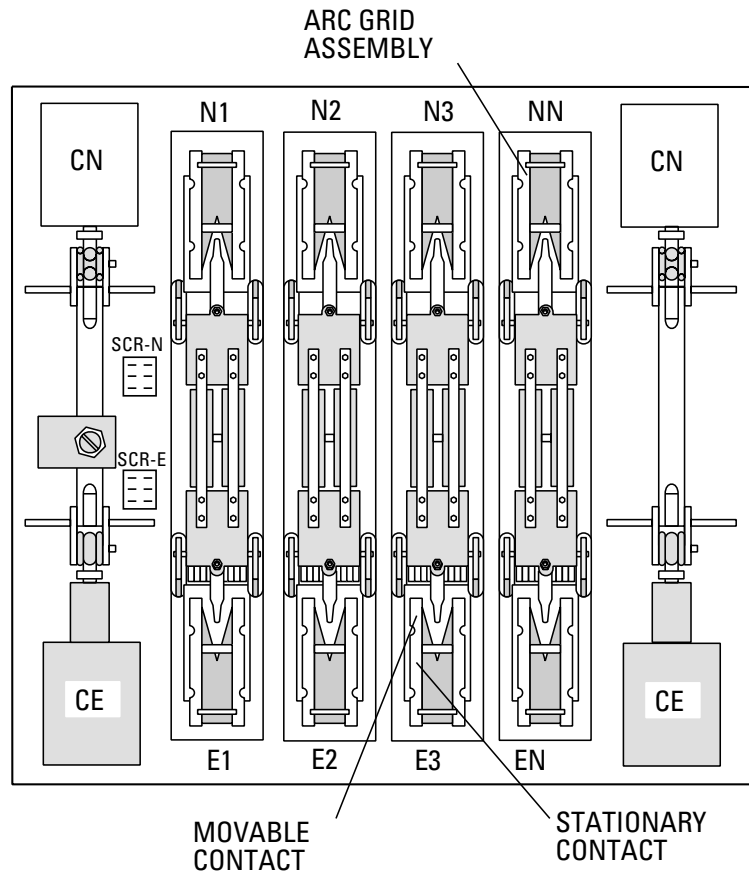
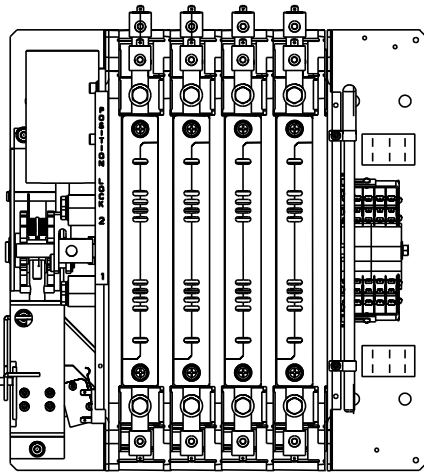

Figure 21

TAG	DESCRIPTION	STOCK NUMBERS		
N 1,2,3, N E 1,2,3, N	Cable Connection Lug	S1511F (3) Optional		
T 1,2,3, N	Wire Size	(12) #2-600 MCM		
	Stationary Contact Assembly Kit	23P-1655		
	Arc Grid Assembly Kit	23P-1171		
	Movable Contact Assembly Kit	23P-1640		
CN/CE	Main Operating Coils	Coil Volts	Poles	
		240	3	K-2219
			4	K-2219
		208	3	K-2226
			4	K-2226
		575/600	3	K-2221
			4	K-2221
		480	3	K-2218
			4	K-2218
		416	3	K-2220
SN	CCN Cut-out Switch	23P-1352		
SE	CCE Cut-out Switch	23P-1356		
A3	Emergency Position Aux Contact	(Qty 1) 23p-1356 (Qty 2) 23p-1357 (Qty 3) 23p-1353 (Qty 4) 23p-1355		
A4	Normal Position Aux Contact	(Qty 1) 23p-1352 (Qty 2) 23p-1353 (Qty 3) 23p-1357 (Qty 4) 23p-1359		
DS	Disconnect Switch	Operator L-4009; ; Contact Block L-1020		
SCR-N/SCR-E	SCR	PS-8896		

Replacement Parts *(cont'd)*

Delayed Transition - 40 to 400 Amps



40-80 Amps

Figure 22

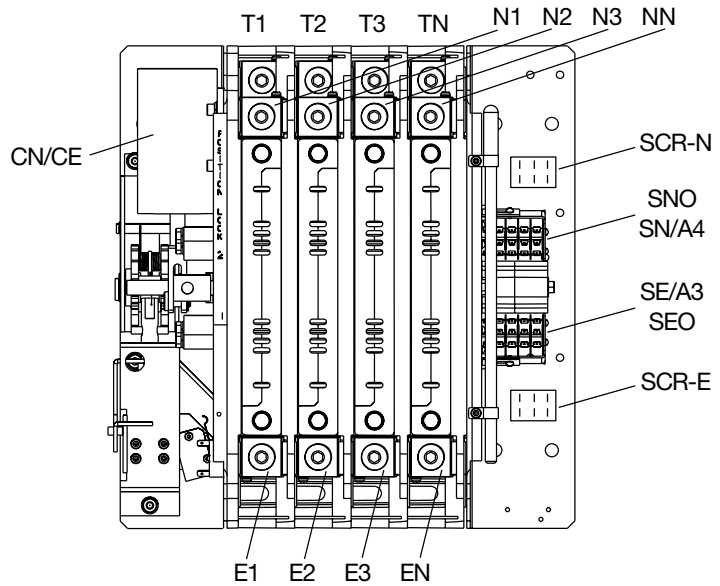

100-400 Amps

Figure 23

Tag	Description	Recommended as Spares	Stock Numbers by Amperage	
			40-80	100-400
N 1,2,3 N	Cable Connection Lug		S-2515	S-2701
E 1,2,3 N	Wire Size		#8 MCM-3/0	#4-600 MCM
T 1,2,3 N				
			Coil Volts	MAIN
			120	K-2245B
			208/240	K-2246B
			380/415	K-2247B
			440/480	K-2248B
			575/600	K-2249B
			575/600	K-2249B
	Handle-Manual		E-3054	
	Handle-Grip		L-3078	
A3/A4	Auxiliary Contacts		L-3078	
SNO/SEO	Coil Cutout Switch		E-3521	
SCR-N/SCR-E	SCR	*	PS-8895	

Replacement Parts *(cont'd)*

Delayed Transition - 600 to 1200 Amps

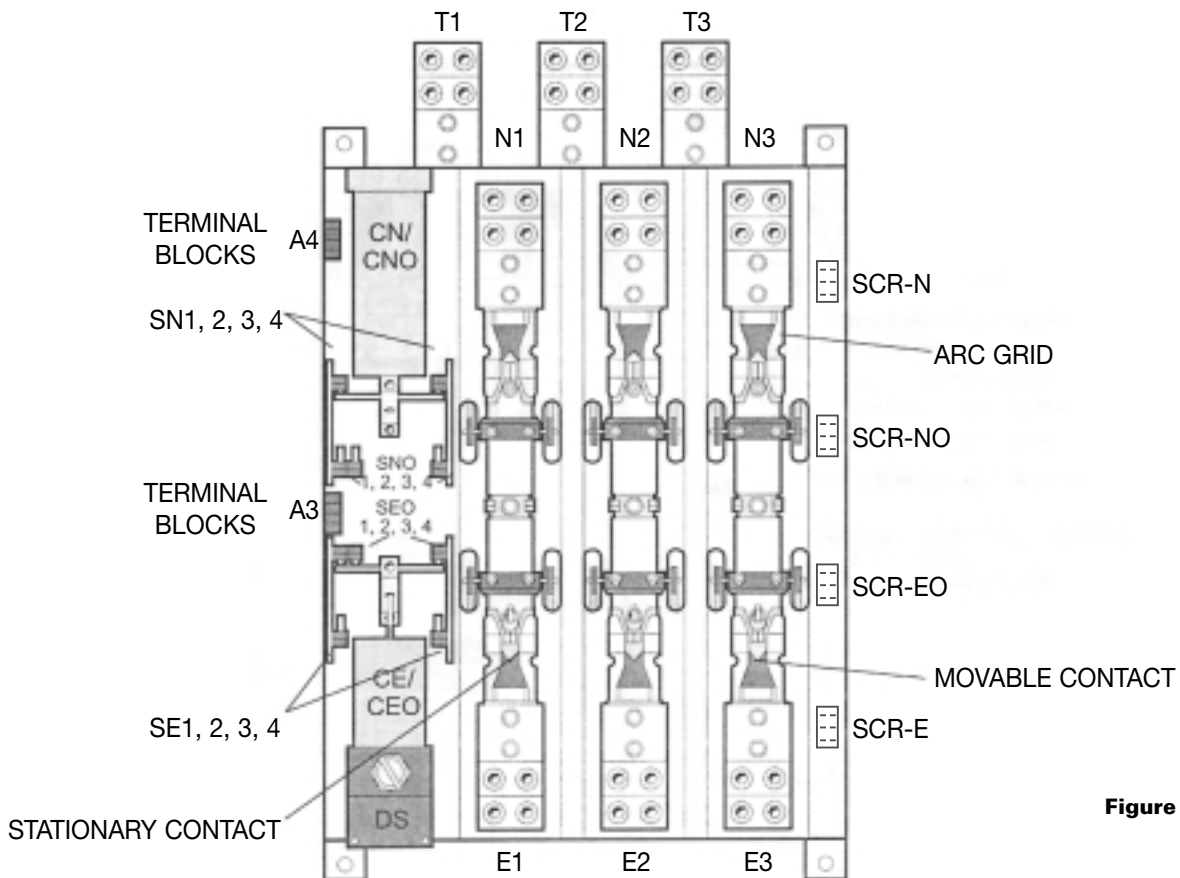
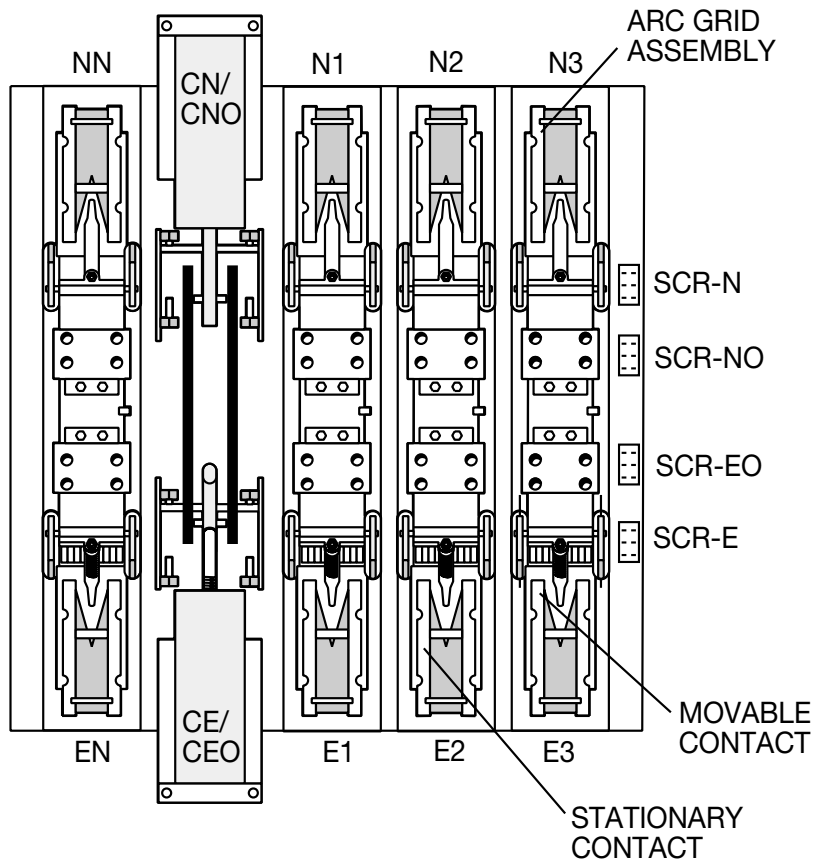

Figure 24

Tag	Description	Recommended as Spares	Stock Numbers by Amperage			
			600-800	1000-1200		
NL 1,2,3 EL 1,2,3 T 1,2,3 NN, EN, TN	Cable Connection Lug, CU Wire		S-1383F (2) 500MCM-2	2-1392F (4) 600MCM-2		
	Stationary Contact Assembly Kit		23P-1471	26P-1336		
	Arc Grid Assembly Kit		23P-1366	23P-1366		
	Movable Contact Assembly Kit		23P-1469	26P-1334		
	Movable Contact		23P-1470	26P-1335		
SCR-N/SCR-E SCR-NO/SCR-EO	SCR	*	PS-8896			
SN/SNO	Limit Switch		23P-1535(L); 23P-1533(R)			
SE/SEO	Limit Switch		23P-1536(L); 23P-1534(R)			
A3	Emergency Position Auxiliary Contact		23P-1536			
A4	Normal Position Auxiliary Contact		23P-1535			
DS	Disconnect Switch	*	Operator: L-4009; Contact Block: L-1020			
CN/CNO CE/CEO	Main Operator Solenoids	*	See Chart Below			
Voltage System				Solenoid Part No.		
Volts	Ph	Wire	Coil VDC	Pole	600	800-1200
240	3	3	240	3	K-2146	K-2147
120/208	3	4	208	3,4	K-2146	K-2147
480	3	3	480	3	K-2158	K-2157
277/480	3	4	480	3,4	K-2158	K-2157
240/416	3	4	416	3	Consult Factory	

Replacement Parts *(cont'd)*

Delayed Transition - 1600 to 3000 Amps



Tag	Description	Recommended as Spares	Stock Numbers by Amperage				
			1600	2000	3000		
N1,2,3 E1,2,3 T1,2,3 NLN,ELN	Cable Connection Lug, CU Wire		S-1126F(2) Optional (8) 600MCM-2				
	Stationary Contact Assembly Kit		23P-4134X	23P-4134Y	23P-4134Z		
	Arc Grid Assembly Kit		23P-1171	23P-1171	23P-1171		
	Movable Contact Assembly Kit		23P-1400	23P-1400	23P-1344		
CN/CNO CE/CEO	Main Operator Solenoids	*	See Chart Below				
SCR-N/SCR-E SCR-NO/SCR-EO	SCR	*	PS-8896				
Voltage System					Solenoid Part No.		
Volts	Ph	Wire	Coil VDC	Pole			
120	1	2	120	2	S.P.O.	S.P.O.	S.P.O.
120/240	1	3	240	2,3	K-2151	K-2151	K-2151
240	3	3	240	3	K-2151	K-2151	K-2151
120/208	3	4	208	3,4	K-2151	K-2151	K-2151
480	3	3	480	3	K-2160	K-2160	K-2160
575	3	3	575/600	3	S.P.O.	S.P.O.	S.P.O.
277/480	3	4	480	3,4	K-2160	K-2160	K-2160
120/240	2	4	240	4	K-2151	K-2151	K-2151
240/416	3	4	416	3	Consult Factory		
Operating Coil Hardware Kit							
SN/SNO-1,2	Switch Bracket Assembly				23P-1540	23P-1540	23P-1540
SE/SEO-1,2	Switch Bracket Assembly				23P-1541	23P-1541	23P-1541
SN/SNO-3,4	Switch Bracket Assembly				23P-1542	23P-1542	23P-1542
SE/SEO-3,4	Switch Bracket Assembly				23P-1543	23P-1543	23P-1543

Replacement Parts *(cont'd)*

Delayed Transition - 4000 Amps

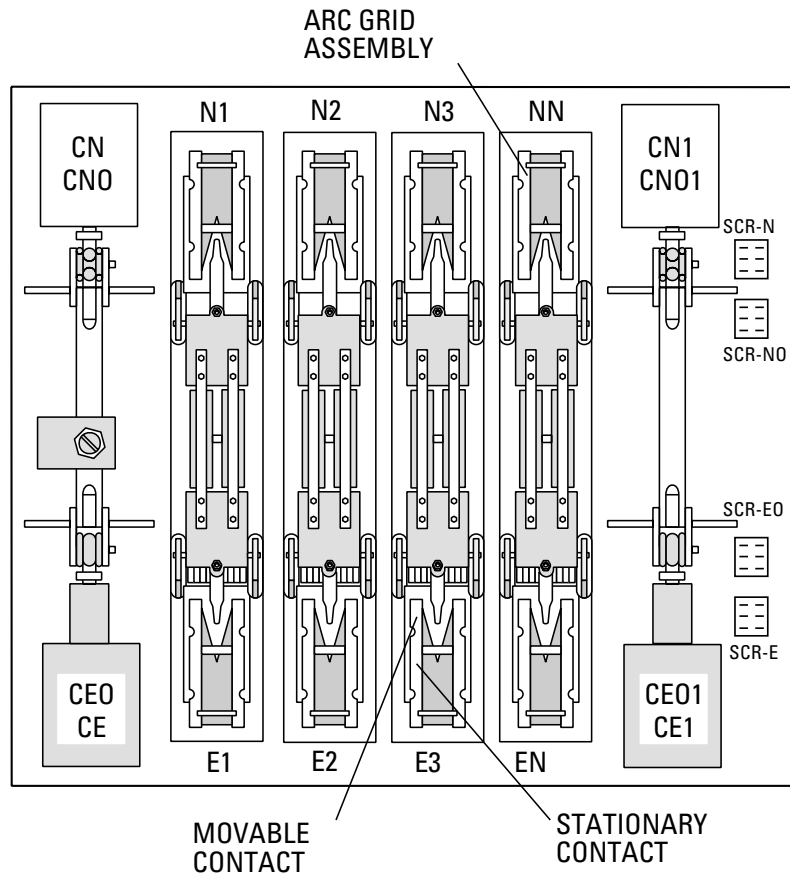

Figure 26

TAG	DESCRIPTION			STOCK NUMBERS
N 1,2,3, N E 1,2,3, N	Cable Connection Lug			S1511F (3) Optional
T 1,2,3, N	Wire Size			(12) #2-600 MCM
	Stationary Contact Assembly Kit			23P-1655
	Arc Grid Assembly Kit			23P-1171
	Movable Contact Assembly Kit			23P-1640
CN/CE	Main Operating Coils	Coil Volts	Poles	
		240	3	K-2215
			4	K-2215
		208	3	K-2227
			4	K-2227
		575/600	3	K-2217
			4	K-2217
		480	3	K-2214
			4	K-2214
		416	3	SPO
SN/SNO	CCN Cut-out Switch		23P-1568	
SE/SEO	CCE Cut-out Switch		23P-1569	
A3	Emergency Position Aux Contact		(Qty 1) 23p-1356 (Qty 2) 23p-1357 (Qty 3) 23p-1353 (Qty 4) 23p-1355	
A4	Normal Position Aux Contact		(Qty 1) 23p-1352 (Qty 2) 23p-1353 (Qty 3) 23p-1357 (Qty 4) 23p-1359	
DS	Disconnect Switch		Operator L-4009; ; Contact Block L-1020	
SCR-N/SCR-E SCR-NO/SCR-EO	SCR		PS-8896	

ZTSH/ZTSDH/ZTSDL/ZTSHL/ZTSDHL

Standard Control Panel Layout (SSRCP)

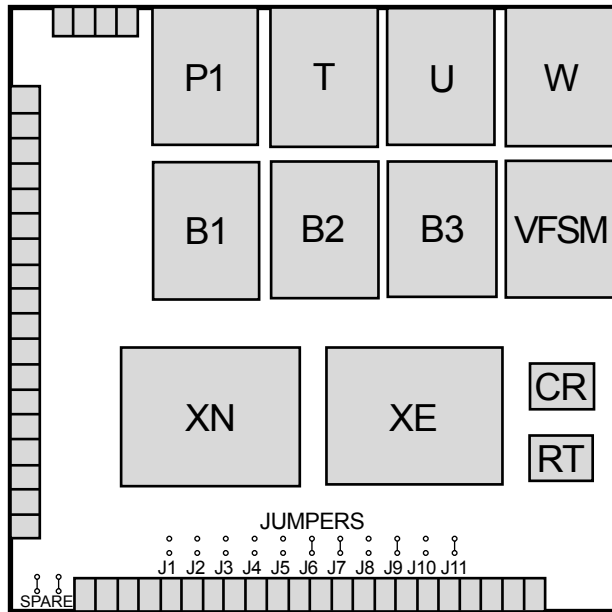

Figure 27

JUMPER	CONNECTS POINTS	REMOVE WHEN ACCESSORIES USED
J1	23, 23A	B1
J2	23A, 23B	B2
J3	23B, 23C	B3
J4	23C, 23Z	JIN, TS, C/D
J5	23Z, 27	T, YN
J6	25, 25Z	T3, R4
J7	28, 28Z	S1, C, C/D
J8	28Z, 29	P1 & U
J9	33A, 33Y	ER1, 2, 3, J1E
J10	33Z, 37	W
J11	35, 35Z	R4, W3

Panel Mount Control Relays

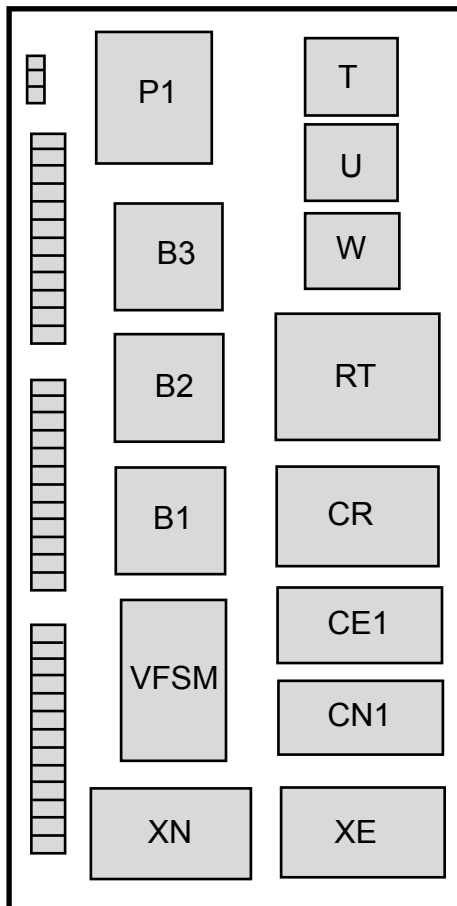
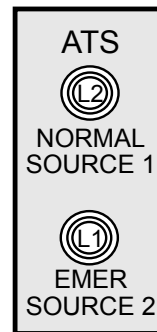

Figure 28



TAG	DESCRIPTION
L1 L2	ATS Source 2 (EMER) Position Indicator ATS Source 1 (NORMAL) Position Indicator Lens Source 1 (NORMAL) Lens Source 2 (EMER) Bulb Socket Source 2 (EMER) Bulb Source 1 (NORMAL) Bulb
TS	Test Switch Operator, Momentary Contact Block N.C. Contact Mounting Base

Sequence of Operation

The information package supplied with the transfer switch includes a schematic diagram and description of operation of all accessories provided.

The sequence for load transfer to Source 2 begins automatically when any phase of Source 1 falls below the preset “fail” or dropout point and this undervoltage failure condition is detected by the solid state phase relays B1, B2, B3.

The phase relays drop out, de-energizing Source 1 control relay CR, and engine start timer P1 begins its timing cycle. The P1 time delay is provided to override momentary outages and to prevent nuisance starting of the engine generator. If Source 1 voltage returns above the “restore” or pickup setting of the phase relays, the P1 timing cycle is reset to zero by the re-energization of the CR relay.

If Source 1 voltage does not return before the P1 time delay is completed, the P1 timer drops out and sends a starting signal to the engine generator. Source 2 voltage and frequency sensing relay VFMS monitors the voltage and frequency of Source 2. When both the voltage and the frequency of Source 2 reach the preset “restore” or pickup points, the VFMS relay initiates the transfer to Source 2 and timer W begins its timing cycle. The W timer provides an adjustable transfer delay to Source 2 as required.

When the W time delay is completed, Source 2 control relay RT energizes and picks up the power relay, CE1 or CCE. The power relay connects voltage from Source 2 to the Source 2 switch operating circuit causing the switch to transfer its main contacts to Source 2. The switch is mechanically locked in Source 2 position. The power relay and Source 2 operator are de-energized when the SE limit switch is activated by the operator. The SN limit switch is deactivated at the same time, readying Source 1 control circuit for retransfer when Source 1 is restored.

The sequence for retransfer to Source 1 begins automatically when the voltage on all phases of Source 1 reach the preset “restore” or pickup point and this condition is detected by the solid state phase relays.

When Source 1 restores, the solid state phase relays B1, B2, B3 pick up and initiate retransfer of the switch to Source 1 by energizing timer T and beginning its timing cycle. The T timer provides an adjustable delay to ensure that Source 1 has stabilized before reconnection to the load. If Source 1 fails before the T time delay is completed, the phase relays drop out and the T timing cycle is reset to zero.

When the T time delay is completed, Source 1 control relay CR energizes and picks up the power relay, CN1 or CNN. The power relay connects voltage from Source 1 to Source 1 switch operating circuit causing the retransfer of the main switch contacts to Source 1. The switch is mechanically locked in Source 1. The power relay and Source 1 operator are de-energized when the SN limit switch is activated by the operator. The SN limit switch also energizes the engine over-run timer U and begins its timing cycle. The timer provides a period of time for the engine generator to run without load and cool down before shutdown. After the U time delay is completed, the P1 timer is energized and the engine generator is shutdown.

Adjustments and Settings

Solid State Timers

Solid state timers are adjustable from 0.1 second to 100 hours. The red timing indicator in the upper left corner flashes as the timer progresses through the timing cycle. When the timing cycle is completed, the indicator remains illuminated. A flathead screwdriver is required to change the setting, as shown in *Figure 30*.

The time unit is selected by turning the rotary switch at the lower right of the timer. Four selections are available: “Seconds”, “Minutes”, “Hours”, “10 Hours”. The time unit selected is displayed in the window below the time setting dial.

The time range is selected by turning the rotary switch at the lower left of the timer. Four ranges are available: “0-0.5”, “0-1.0”, “0-5.0”, “0-10.0”. The dial digits appear in the windows around the time setting knob.

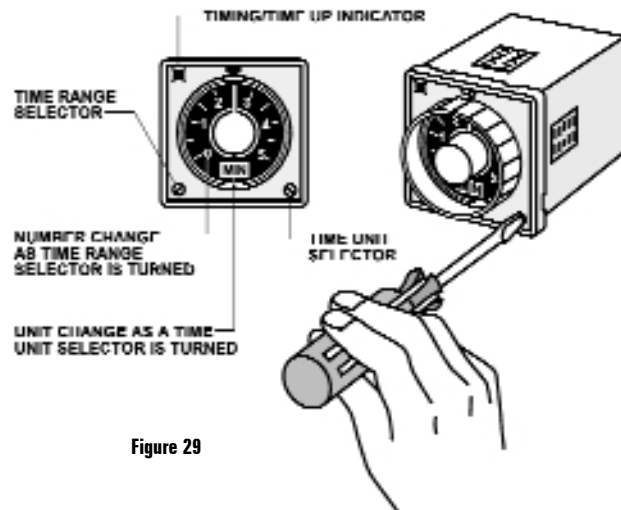

Figure 29

⚠ CAUTION ⚠

Do NOT change the setting while the timer is energized. Timer malfunction or damage may occur.

The factory setting of the solid state timers used in the Zenith standard package are shown in *Table 4*.

Timer	Factory Setting
T	30 minutes
U	5 minutes
W	1 second

Table 4

Voltage/Frequency Sensor (VFSM)

The “restore” or pickup point may be adjusted by rotating the adjustment screw as shown in *Figure 31*. Counter-clockwise rotation increases the pickup voltage.

“Restore”/Pickup Voltage (at 100% Frequency)

Adjustable: 80% to 95%

Factory Set: 90%

“Restore”/Pickup Frequency

Adjustable: 80% to 100%

Factory Set: 95%

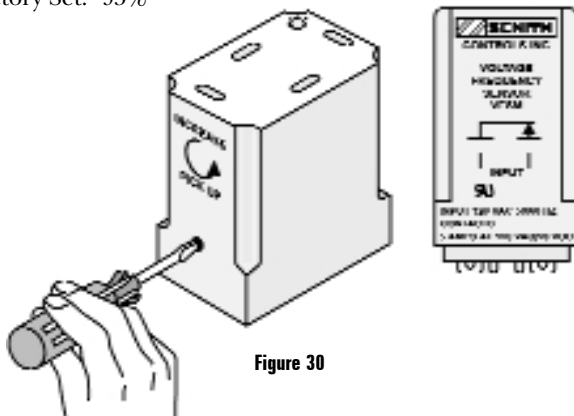

Figure 30

Solid State Phase Relay (ARSM)

The “restore” or pickup and “fail” or dropout points may be adjusted by using the following procedure. Use of a variable voltage supply (Variac) is required. The relay is illustrated in *Figure 32*.

1. Turn the “restore” or pickup adjustment fully clockwise.
2. Turn the “fail” or dropout adjustment fully counter-clockwise.
3. Set Variac to the desired “restore” or pickup voltage.
4. Rotate the “restore” or pickup adjustment counter-clockwise very slowly until the relay picks up. The LED will illuminate.
5. Set Variac to the desired “fail” or dropout voltage.
6. Rotate the “fail” or dropout adjustment clockwise very slowly until the relay drops out. The LED will go out.
7. Verify the setting by raising the voltage until the relay restores or picks up and lowering the voltage until the relay fails or drops out.

“Restore”/Pickup Voltage:

75% to 115% of Nominal

Factory Set:

90% of Nominal

“Fail”/Dropout Voltage:

55% to 105% of Nominal

Factory Set:

80% of Nominal

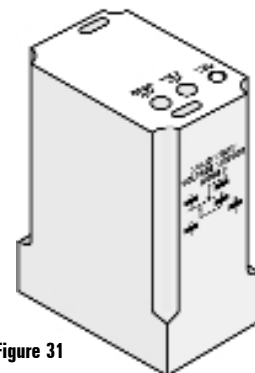

Figure 31



GE Zenith Controls

A Product of GE Industrial Systems

General Electric Company

830 West 40th Street, Chicago, IL 60609 USA

773 299-6600, Fax: 773 247-7805

www.geindustrial.com